

This addendum provides instructions to properly attach the Uprights and Outer Junction Covers to the Bowflex™ Treadmill 10 / Treadmill 22 / Treadmill 25 / Treadmill 56.

If you need assistance, please contact Customer Service (if purchased in US/Canada) or your local distributor (if purchased outside US/Canada). To find your local distributor, go to: www.nautilusinternational.com

This icon means a potentially hazardous situation which, if not avoided, could result in death or serious injury. Read and understand all Warnings on this machine.

Nautilus, Inc., www.NautilusInc.com, 5415 Centerpoint Parkway, Groveport, OH 43125 U.S.A. - Customer Service: North America (800) 605-3369, csnls@nautilus.com | outside U.S. www.nautilusinternational.com | Printed in China | © 2020 Nautilus, Inc. | Bowflex and the B logo are trademarks owned or licensed by Nautilus, Inc., registered or otherwise protected by common law in the United States and other nations. | **ORIGINAL DOCUMENT - ENGLISH VERSION ONLY**

Refer to the Assembly Manual for complete safety instructions.

Assembly Step 1. Attach the Uprights to the Base Assembly, and then Connect the Cables from the Base Assembly to the Right Upright

Note: Do not crimp cables. Do not fully tighten Hardware until instructed.

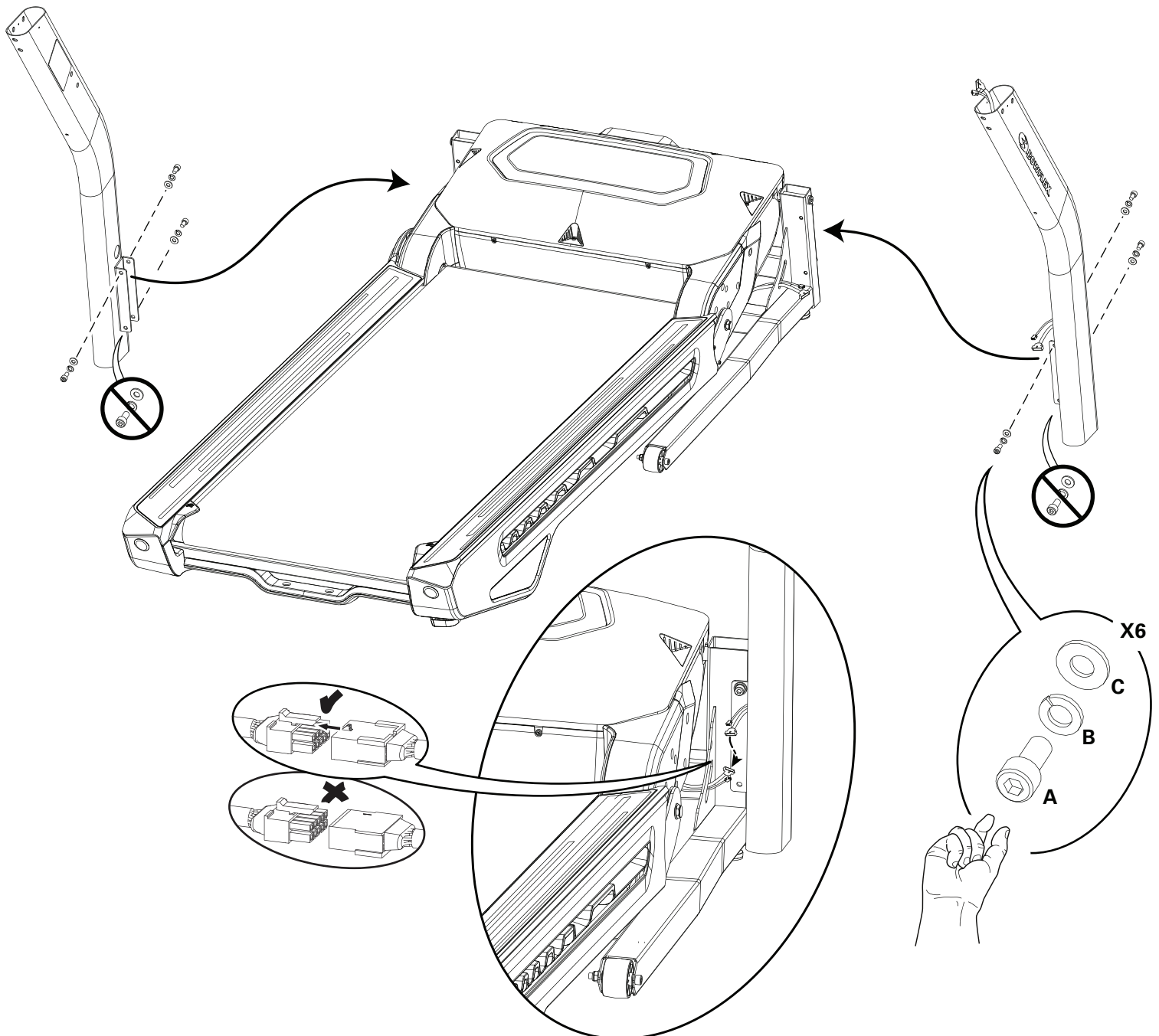

Assembly Step 7. Attach the Base Shrouds and Outer Junction Covers to the Frame Assembly

Note: Be sure that the Right Base Shroud hides the Cable Connectors. If necessary, push the Cable further into the Right Upright.

