

## Max Trainer M8: The pedals are making a noise or not staying on track

ID: 11248.2

Follow this troubleshooting guide to help resolve issues involving the rollers and/or pedal arms on the Max Trainer M8. See below for a diagram of the leg assembly showing the location of these parts.

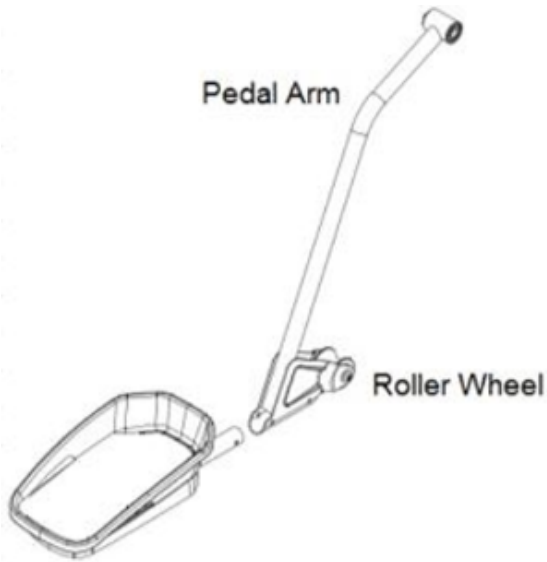

Some common complaints may include:

- Damaged roller wheels
- Maligned leg assemblies
- Noise originating from the pedal arms

### **Follow these steps to troubleshoot the issue**

Tools you may need for all troubleshooting steps:

Phillips head screwdriver  
6mm, 8mm hex/Allen wrenches, or the Allen wrenches from the hardware card included with your machine  
14mm socket wrench

1. Check that the roller wheels are aligned properly and stay on the rails during use. Inspect the roller wheels for damage. If damage is present, [order Roller Wheels \[11248.A\]](#).
2. If the roller wheels seem "off" or do not stay on the rails, please refer to the "Adjust the Leg Assembly Alignment" instructions in the [Service Manual \[11248.B\]](#).
3. If adjusting the leg assembly alignment did not resolve the issue, confirm if the wave washers are installed where the pedal arm mounts on the crank arm (**reference 1**) [\[11248.C\]](#).

**(Reference 1)**

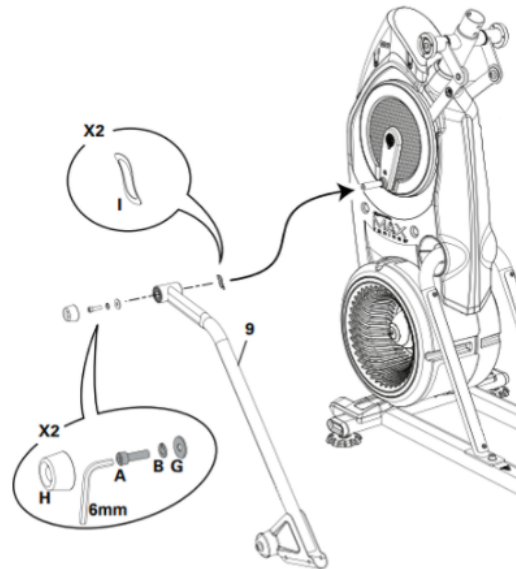

The Wave Washers (part labeled 'I') should be installed on the crank arm, indicated by the black arrow. Once installed, the pedal arm (part 9) should be attached to the crank arm.

4. If the wave washers are not installed, [order a Wave Washer Kit \[11248.D\]](#).

**Note:**

- It is normal for the pedal arm to slide back and forth slightly where it connects to the crank arm.
- This motion is critical for proper machine function - the wave washer acts as a cushion to soften the movement.
- Do not install more than one wave washer per pedal arm, as this will reduce its effectiveness.

5. If the wave washers are installed, remove both pedal arms using a 6mm Allen wrench. Using a Phillips head screwdriver, remove the plastic crank covers from both sides of the machine. Be careful to not use a screwdriver that is too small. The screws may be tight and strip easily.
6. Using a 14mm socket wrench, tighten both crank nuts as much as possible [\[11248.E\]](#). Reinstall the pedal arms, but swap them to the opposite side. If the issue persists on the original side, [order a Crank Arm](#) for the affected side [\[11248.F\]](#). If the issue persists but followed the pedal arm when swapping, [order a Pedal Arm \[11248.G\]](#).
- **Important:** a crank puller is required to remove/replace the crank arms. If you are ordering crank arms, [order a Crank Puller](#) as well.

**Need to order replacement parts?**

1 Customer Care Contact Information

Please contact Customer Care at **1-800-605-3369** for additional help or to order replacement parts. Some replacement parts may also be available for purchase [online here](#). A list of part numbers referenced within this guide can be located at the bottom of this page.

**Customer Care - Hours of Operation:**  
Monday - Friday 6:00am - 5:00pm PST

*The replacement part will be provided to you at no cost assuming your machine meets the warranty eligibility requirements. A Customer Care Agent will be able to assess your current warranty eligibility and provide you with your options.*

*Please note that if you did not purchase your machine directly from BowFlex, Schwinn, or Nautilus, we will need a copy of your purchase receipt in order to register your machine for warranty.*

## 2 Parts Reference Table

<i>Part Description</i>	<i>Part SKU</i>
<b>Crank Arm, Left</b>	<b>8020199</b>
<b>Crank Arm, Right</b>	<b>8020198</b>
<b>Crank Puller</b>	<b>74025</b>
<b>Roller Wheel</b>	<b>8004550</b>
<b>Pedal Arm</b>	<b>8019245</b>
<b>Wave Washer Kit</b>	<b>8018502</b>

## 3 Contact Tech Team / Advanced Troubleshooting

***If the issue was not resolved in the steps listed, contact the Tech Team or send an Advanced Troubleshooting case.***

**Submit a Case with case type Advanced Troubleshooting**