



If purchased in US/Canada:

⚠ WARNING

Do not operate this machine until you read and understand the complete Owner's Manual provided online here: <http://www.bowflex.com/manuals>

In the event that you do not have a computer or on-line access and require a hard copy of the Manual, please contact Nautilus at (800) 605-3369 and we will provide one for you. In either case, before first use please read and understand the Owner's Manual.

If purchased outside US/Canada:

⚠ WARNING

Do not operate this machine until you read and understand the complete Owner's Manual provided online here: www.nautilusinternational.com or www.nautilus.cn

To validate warranty support, keep the original proof of purchase and record the following information:

Serial Number _____

Date of Purchase _____

If purchased in US/Canada: To register your product warranty, go to: www.bowflex.com/register or call 1 (800) 605-3369.

If purchased outside US/Canada: To register your product warranty, contact your local distributor.

For warranty and service of products purchased outside US/Canada, please contact your local distributor. Nautilus, Inc. will cover the frame and drive motor. Contact your local distributor for key details. To find your local international distributor, go to: www.nautilusinternational.com.

Workout with Other Fitness Apps

This fitness machine has integrated Bluetooth® connectivity which allows it to work with a number of fitness apps. For our latest list of supported apps, please visit: www.nautilus.com/partners

IMPORTANT SAFETY INSTRUCTIONS

When using an electrical appliance, basic precautions should always be followed, including the following:



This icon means a potentially hazardous situation which, if not avoided, could result in death or serious injury.

Obey the following warnings:



Read and understand all warnings on this machine.

Carefully read and understand the Assembly instructions. Read and understand the complete Manual. Keep the Manual for future reference.

- Keep bystanders and children away from the product you are assembling at all times.
- Do not connect power supply to the machine until instructed to do so.
- To reduce the risk of electrical shock or unattended/unsupervised usage, always unplug the AC Adapter from the wall outlet and the machine and wait 5 minutes before cleaning, maintaining or repairing the machine. Place the AC Adapter in a secure location.
- Do not assemble this machine outdoors or in a wet or moist location.
- Make sure assembly is done in an appropriate work space away from foot traffic and exposure to bystanders.
- Some components of the machine can be heavy or awkward. Use a second person when doing the assembly steps involving these parts. Do not do steps that involve heavy lifting or awkward movements on your own.

- Set up this machine on a solid, level, horizontal surface.
- Do not try to change the design or functionality of this machine. This could compromise the safety of this machine and will void the warranty.
- If replacement parts are necessary use only genuine replacement parts and hardware supplied by Nautilus. Failure to use genuine replacement parts can cause a risk to users, keep the machine from operating correctly and void the warranty.
- Do not use or put the machine into service until the machine has been fully assembled and inspected for correct performance in accordance with the Manual.
- Read and understand the complete Manual supplied with this machine before first use. Keep the Manual for future reference.
- Do all assembly steps in the sequence given. Incorrect assembly can lead to injury or incorrect function.
- Connect this machine to a properly grounded or earthed outlet only.
- Keep the AC Adapter away from heat sources and hot surfaces.

• SAVE THESE INSTRUCTIONS.

Before using this equipment, obey the following warnings:



Read and understand the complete Manual. Keep the Manual for future reference.

Read and understand all warnings on this machine. If at any time the Warning stickers become loose, unreadable or dislodged, replace the labels. If purchased in US/Canada, contact Customer Service for replacement labels. If purchased outside US/Canada, contact your local distributor for them.

- Children must not be let on or near to this machine. Moving parts and other features of the machine can be dangerous to children.
- Not intended for use by anyone under 14 years of age.
- Consult a physician before you start an exercise program. Stop exercising if you feel pain or tightness in your chest, become short of breath, or feel faint. Contact your doctor before you use the machine again. Use the values calculated or measured by the machine's computer for reference purposes only.
- Before each use, examine this machine for damage to power cord, power receptacle, loose parts or signs of wear. Do not use if found in this condition. Monitor the Seat, Pedals and Crank Arms closely. If purchased in US/Canada, contact Customer Service for repair information. If purchased outside US/Canada, contact your local distributor for repair information.
- This appliance should only be used with the power supply unit provided, or a replacement power supply unit supplied from Nautilus, Inc.
- Maximum user weight limit: 150 kg (330 lbs.). Do not use if you are over this weight.
- This machine is for home use only. Do not place or use the machine in a commercial or institutional setting. This includes gyms, corporations, work places, clubs, fitness centers and any public or private entity that has a machine for use by its members, customers, employees or affiliates.
- Do not wear loose clothing or jewelry. This machine contains moving parts. Do not put fingers or other objects into moving parts of the exercise equipment.
- Always wear rubber soled athletic shoes or cycling shoes with cleats when you use this machine. Do not use the machine with bare feet or only wearing socks.
- Set up and operate this machine on a solid, level, horizontal surface.
- Do not step off the machine until the Pedals have fully stopped.
- Make the Pedals stable before you step on them. Use caution when you step on and off the machine.
- Disconnect all power before servicing this machine.
- Do not operate this machine outdoors or in moist or wet locations. Keep the Pedals clean and dry.
- Keep at least 0.6 m (24") along the side used to access the machine and to the rear of the machine clear. This is the recommended safe distance for access, passage and emergency dismounts from the machine. Keep third parties out of this space when machine is in use.
- Do not over exert yourself during exercise. Operate the machine in the manner described in this manual.
- Perform all regular and periodic maintenance procedures recommended in the Owner's Manual.
- Do not drop or put objects into any opening of the machine.
- Correctly adjust and safely engage all Positional Adjustment Devices. Make sure that the Adjustment Devices do not hit the user.
- Exercise on this machine requires coordination and balance. Be sure to anticipate that changes in speed and resistance level can occur during workouts, and be attentive in order to avoid loss of balance and possible injury.
- Since this machine operates with a fixed gear, do not back, or reverse, pedal. Doing so may loosen the Pedals, which could result in damage to the machine and/or injury to the user. Never operate this machine with loose Pedals.
- For safe storage of the machine, remove the power supply and place in a secure location. Tighten the Brake/Resistance Adjustment Knob as described until the Flywheel is locked. Place the machine in a secure location away from children and pets.
- This appliance is not intended for use by persons (including children) with reduced physical, sensory or mental capabilities, or lack of experience and knowledge, unless they have been given supervision or instruction concerning use of the appliance by a person responsible for their safety.
- This bike cannot stop the Pedals independently of the Flywheel. Reduce the pace to slow the Flywheel and Pedals to a stop. Do not dismount the bike until the Pedals have come to a complete stop. Be aware that the moving Pedals can strike the backs of the legs.
- Children should be supervised to ensure that they do not play with the appliance.
- Use the values calculated or measured by the machine's computer for reference purposes only. The heart rate displayed is an approximation and should be used for reference only. Over exercising may result in serious injury or death. If you feel faint stop exercising immediately.

• SAVE THESE INSTRUCTIONS.

FCC Compliance

⚠ Changes or modifications to this unit not expressly approved by the party responsible for compliance could void the user's authority to operate the equipment.

This product complies with part 15 of the FCC rules. Operation is subject to the following two conditions: (1) This device may not cause harmful interference, and (2) this device must accept any interference received, including interference that may cause undesired operation.

Note: This product has been tested and found to comply with the limits for a Class B digital device, pursuant to CFR47 Part 15 Subpart B of the FCC Rules. These limits are designed to provide reasonable protection against harmful interference in a residential installation. This equipment generates radio frequency energy and, if not installed and used in accordance with the instructions, may cause harmful interference to radio communications.

However, there is no guarantee that interference will not occur in a particular installation. In the unlikely event that this equipment does cause harmful interference to radio or television reception, which can be determined by turning the equipment off and on, the user is encouraged to try to correct the interference by one or more of the following measures:

- Reorient or relocate the receiving antenna.
- Increase the separation between the equipment and receiver.
- Consult the dealer or an experienced radio/TV technician for help.

This product complies with the European Radio Equipment Directive 2014/53/EU

Specifications

Maximum User Weight:	150 kg (330 lbs.)
Machine Weight without Dumbbells:	48.1 kg (106 lbs.)
Weight of Dumbbells (supplied in U.S./Canada):	2.7 kg (6 lbs.)
Total Surface Area (footprint) of equipment:	6667 cm ² (1032.4 in ²)

Power Requirements

(Power Adapter):

Input Voltage:	100-240V AC, 50-60Hz, 0.5A
Output Voltage:	9V DC, 1.5A

(Arm Band - supplied in U.S./Canada): Rechargeable lithium battery



DO NOT dispose of this product as refuse. This product is to be recycled. For proper disposal of this product, please follow the prescribed methods at an approved waste center.

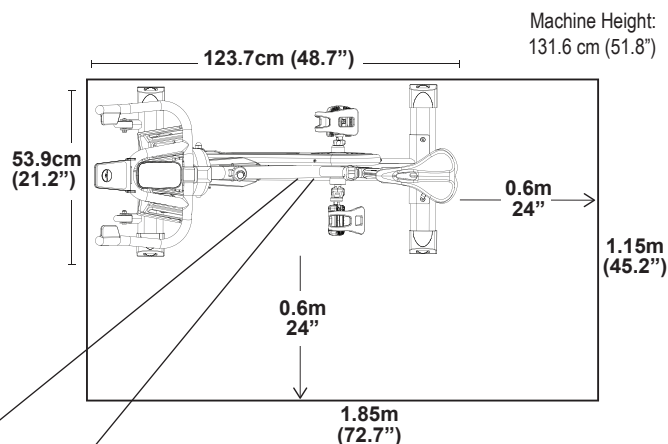

Serial Number and Product Specification



WARNING!

- Injury or death is possible if caution is not used while using this machine.
- Keep children and pets away.
- Read and follow all warnings on this machine.
- Refer to the Owner's Manual for additional warnings and safety information.
- The heart rate displayed is an approximation and should be used for reference only.
- Not intended for use by anyone under 14 years of age.
- The maximum user weight for this machine is 330 lbs (150 kg.).
- This machine is for home use only.
- Consult a physician prior to using any exercise equipment.

(Label is only available in English and French Canadian.)

Before Assembly

Select the area where you are going to set up and operate your machine. For safe operation, the location must be on a hard, level surface. Allow a workout area of a minimum 1.15m x 1.85m (45.2" x 72.7"). Keep the workout area clear 0.6m (24") along the side used to access the machine and to the rear of the machine.

Assembly

Item	Qty	Description
A	2	Adjustment Handle, Handlebar / Seat
B	2	Flat Washer, M10 Wide
C	1	Adjustment Handle, Handlebar Post

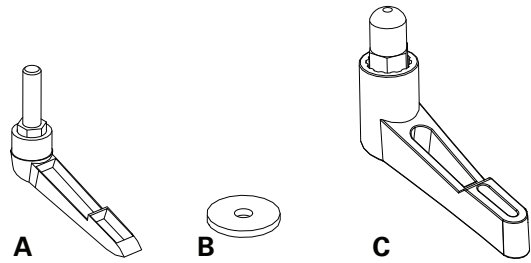

Tools

Included



3 mm



#2
6 mm



15 mm
17 mm

Step 1.

NOTICE: Make sure the Handlebar Post Adjustment Handle engages the holes in the Handlebar Post, and the Seat Adjustment Knob engages the holes in the Seat Post. When fully tightened, the Handlebar Post Adjustment Handle must point downward.

Note: The hardware (*) is pre-installed and not in the Hardware Bag. If a tube is pre-installed in the stabilizer bracket, remove and set it safely aside.

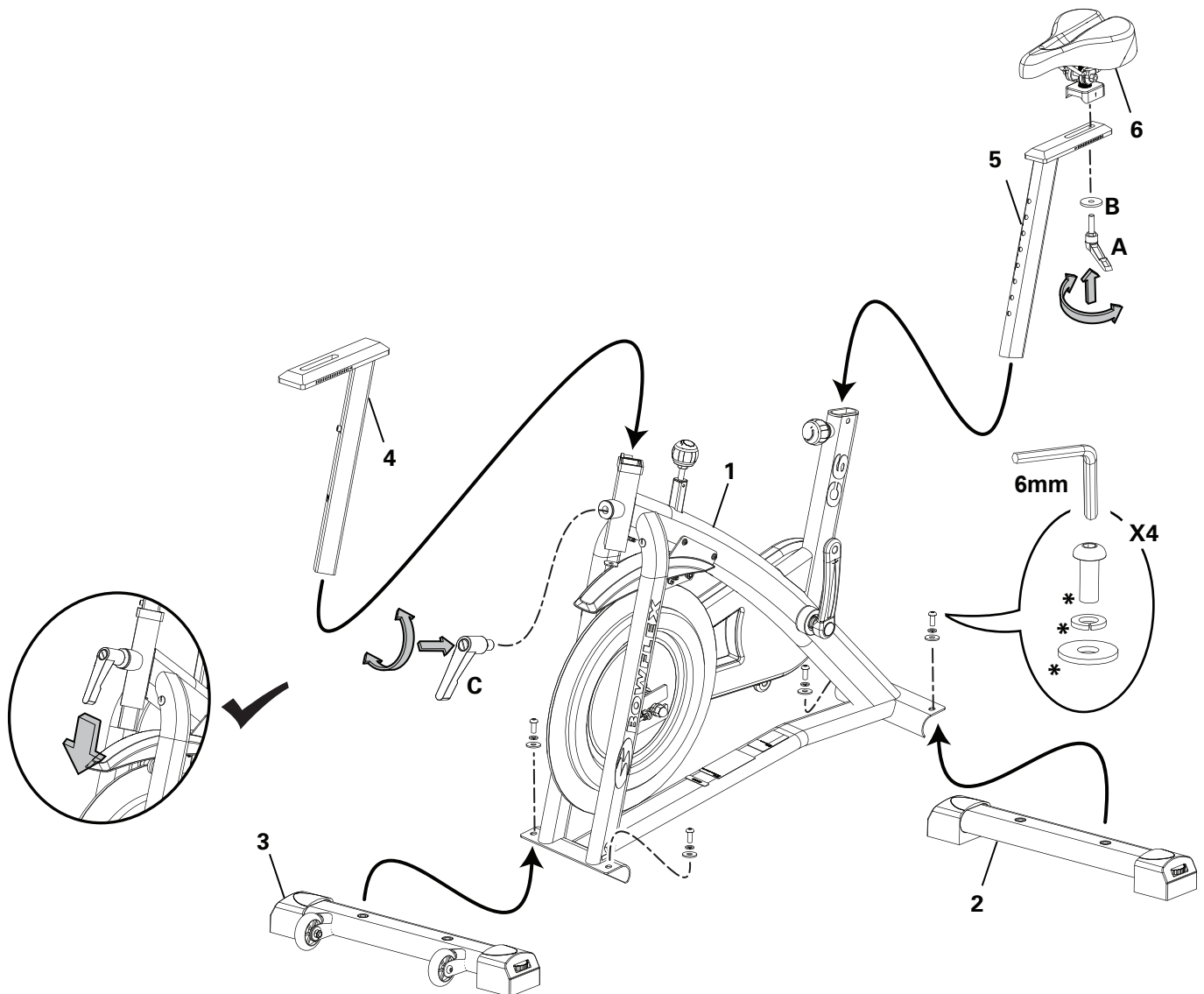

Item	Qty	Description	Item	Qty	Description	Item	Qty	Description
1	1	Frame	3	1	Stabilizer, Front	5	1	Seat Post
2	1	Stabilizer, Rear	4	1	Handlebar Post	6	1	Seat

Step 2.

! If the threads strip due to improper installation, then the Pedals can disengage from the bike and/or break while under usage, which can result in serious injury to the user.

Note: The Left Pedal is reverse-threaded. Be sure to attach Pedals on the proper side of the Bike. Orientation is based from a seated position on the bike. The Left Pedal has an "L", the Right Pedal an "R".

NOTICE: The Pedals MUST be installed straight into the Crank Arms by hand or the threads that secure the Pedals may strip. Start the Pedal by hand. If you feel resistance and the Pedal does not turn smoothly into the Crank Arm, make sure that the threads are aligned correctly. Be sure that the Pedal is going on straight into the Crank Arm. If the Pedal is not in-line with the opening, remove the Pedal and start again.

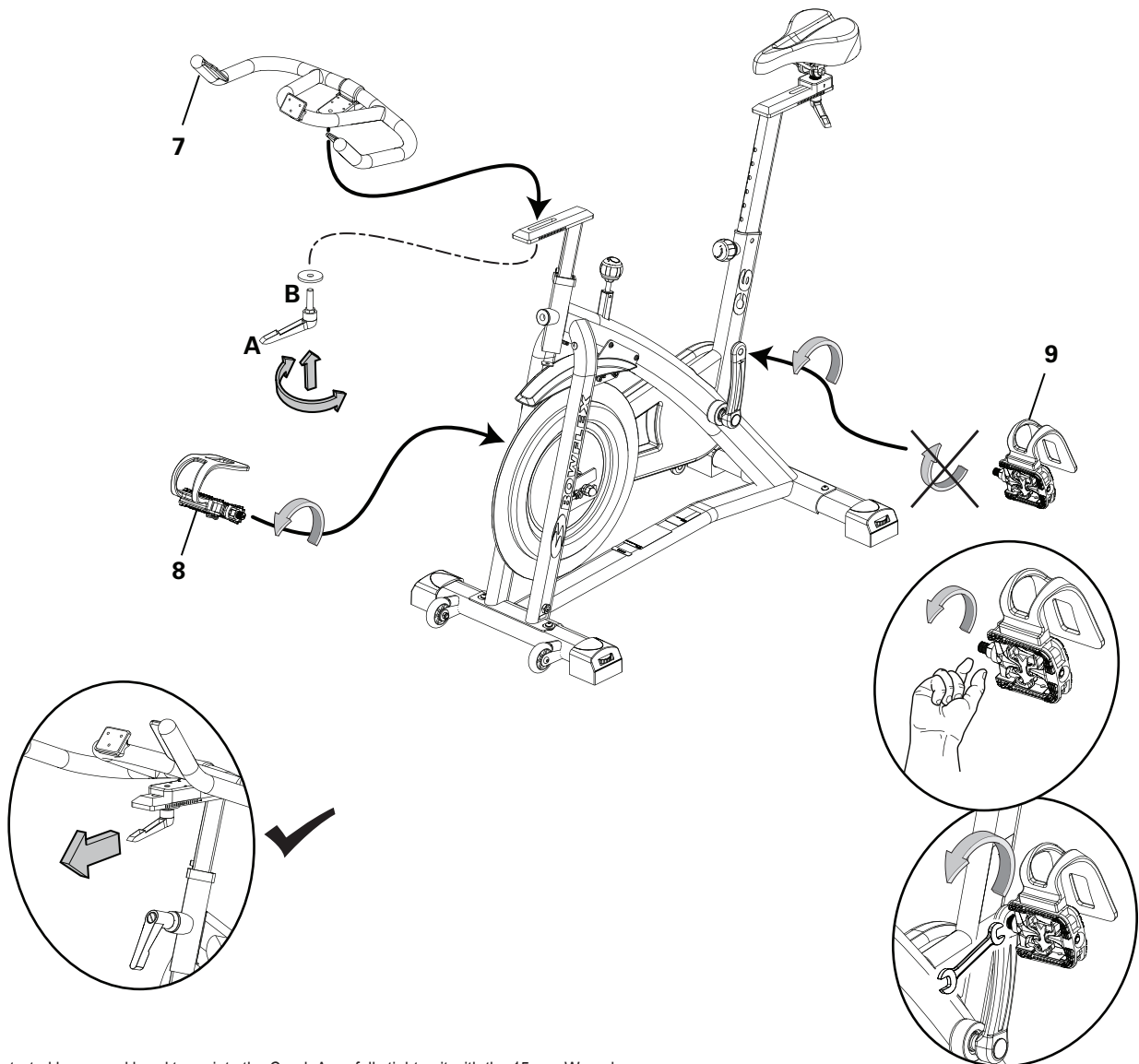
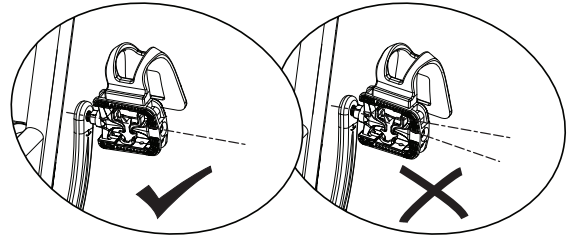

With the Pedal started by several hand turns into the Crank Arm, fully tighten it with the 15 mm Wrench.

Confirm that the Pedal is fully tightened with the Wrench.

Repeat with the other Pedal.

Item	Qty	Description	Item	Qty	Description	Item	Qty	Description
7	1	Handlebar	8	1	Pedal, Right	9	1	Pedal, Left

Step 3.

NOTICE: The hardware (*) is pre-installed and not in the Hardware Bag. Remove the pre-installed screws from the back of the Console before you connect the cable. Do not crimp the cable.

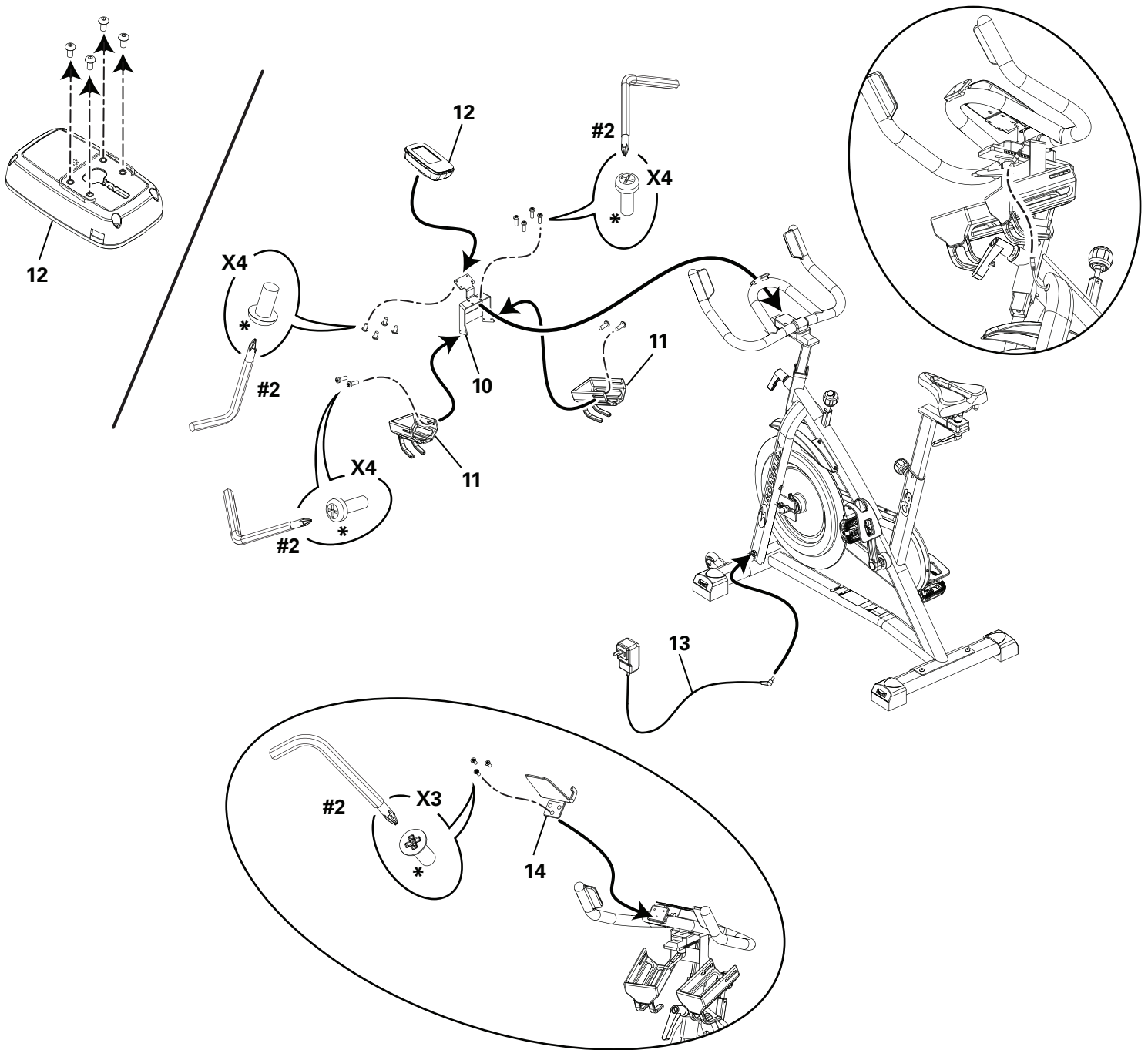

Item	Qty	Description	Item	Qty	Description	Item	Qty	Description
10	1	Water Bottle Bracket	12	1	Console	14	1	Media Tray
11	2	Water Bottle Holder	13	1	AC Adapter			

Step 4.

Final Inspection

Inspect your machine to ensure that all hardware is tight and components are properly assembled. Be sure that the Pedals are fully tightened.

Be sure to record the serial number in the field provided at the front of this manual.



Do not use until the machine has been fully assembled and inspected for correct performance in accordance with the Owner's Manual.

Moving and Storing the Machine

! The machine may be moved by one or more persons depending on their physical abilities and capacities. Make sure that you and others are all physically fit and able to move the machine safely.

1. Remove the dumbbells, any media devices, or water bottles from the bike before moving it.
2. To lock the Flywheel, turn the Emergency Brake/Resistance Adjustment Knob clockwise until it encounters an increase in resistance. Then rotate the Emergency Brake/Resistance Adjustment Knob another 1/2 turn clockwise.

! Tighten the Emergency Brake/Resistance Adjustment Knob as described until the Flywheel is locked before moving it.

3. To move the bike, carefully pull the Handlebars toward you while pushing the front of the bike downward. Push the bike to the desired location.

NOTICE: Be careful when you move the machine. Abrupt motions can affect the computer operation.

! For safe storage of the machine, remove the power supply and place in a secure location. Tighten the Brake/Resistance Adjustment Knob as described until the Flywheel is locked. Place the machine in a secure location away from children and pets.

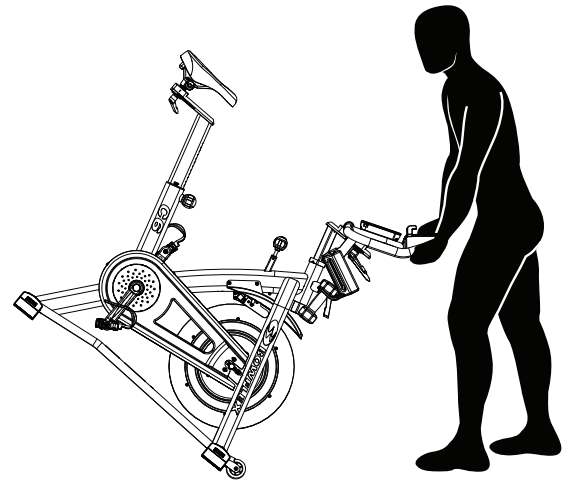

Leveling the Machine

The machine needs to be leveled if your workout area is uneven. Levelers are found on each side of the stabilizers. Lift the stabilizer slightly to take the weight off the adjuster, then turn the knob to adjust the stabilizer foot.

! Do not adjust the levelers to such a height that they detach or unscrew from the machine. Injury to you or damage to the machine can occur.

Make sure the machine is level and stable before you exercise.

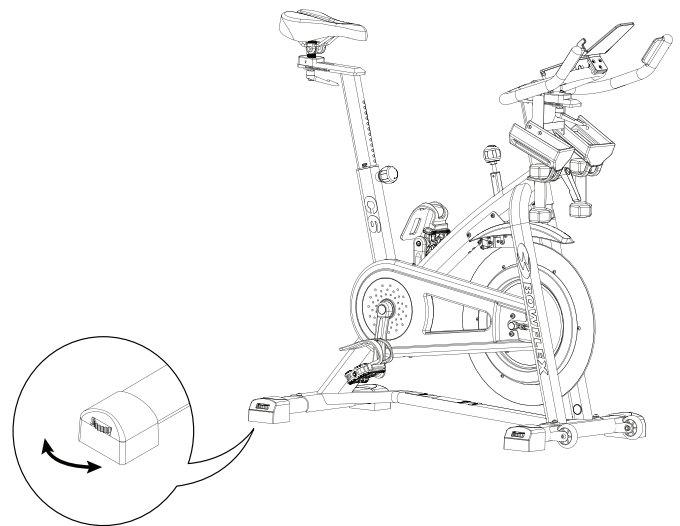

Emergency Stop

To stop the pedals immediately, push down hard on the Emergency Brake/Resistance Adjustment Knob.

! This bike cannot stop the Pedals independently of the Flywheel. Reduce the pace to slow the Flywheel and Pedals to a stop. Do not dismount the bike until the Pedals have come to a complete stop. Be aware that the moving Pedals can strike the backs of the legs.

Using your JRNY™ membership with your machine

If you have a JRNY™ membership*, it can be accessed through your device when synced to the console of this Bowflex™ machine. With a JRNY™ membership, you receive guided workouts adapted to your capabilities, conveniently displayed on your device, and friendly virtual voice coaching designed to support you on your journey to long-term fitness success.

1. Download the app, named "Bowflex™ JRNY™". The app is available on the App Store and Google Play™.
2. Be sure that the Bluetooth® and Location Settings are active on your device. Activate them if necessary.
3. Open the app near the machine, and follow the instructions to sync your device to the machine.

If the app will not sync to the machine, restart your device and the machine. Repeat Step 3.

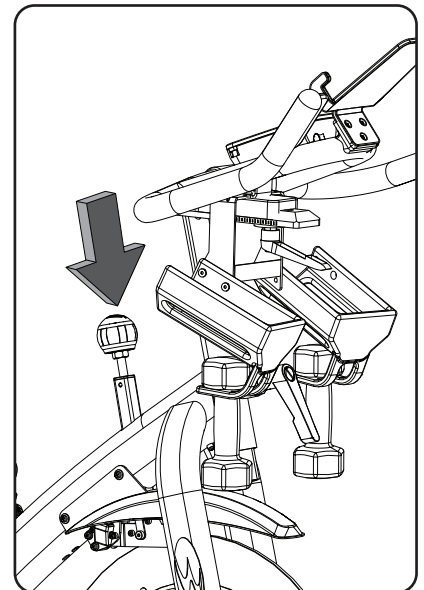

* A JRNY™ membership is required for the JRNY™ experience – see www.bowflex.com/jrny for details. For United States and Canada customers, you can obtain a JRNY™ membership by calling 800-269-4126 or visiting www.bowflex.com/jrny. Where available (including the United States), you can also obtain a JRNY™ membership by downloading the JRNY™ app onto your phone or tablet and signing up within the downloaded app. JRNY™ memberships may not be available in all countries.

Workout with Other Fitness Apps

This fitness machine has integrated Bluetooth® connectivity which allows it to work with a number of fitness apps. For our latest list of supported apps, please visit: www.nutilus.com/partners

Bluetooth® Heart Rate Enabled

Your fitness machine is equipped to be able to receive a signal from a Bluetooth® Heart Rate Sensing device. When connected, the Console will display the Bluetooth® Heart Rate Monitor Connected icon. Be sure to follow the described method to sync your device.



If you have a pacemaker or other implanted electronic device, consult your doctor before using a Bluetooth® strap or other Bluetooth® heart rate monitor.

Bluetooth® Heart Rate Monitor (supplied in the U.S. / Canada only)

Your fitness machine is equipped to be able to receive a signal from a Bluetooth® Heart Rate (HR) Monitor. Follow the instructions provided with your Bluetooth® HR monitor.



If you have a pacemaker or other implanted electronic device, consult your doctor before using a Bluetooth® armband or other Bluetooth® heart rate monitor.

Note: Be sure to remove the protective cover (if provided) from the Heart Rate Sensor before use.

1. Put on your Bluetooth® Heart Rate monitor and activate it.
2. Push the Connect Bluetooth® Heart Rate button on the Console. The Console will actively search for any monitors in the area, and will rapidly flash the Bluetooth® Heart Rate Monitor Connected icon.
3. When connected, the Bluetooth® Heart Rate Monitor Connected icon will flash with your pulse and your current heart rate value will be displayed on the Console. You are now ready to workout.

At the end of your workout, push the Connect Bluetooth® Heart Rate button to disconnect your HR monitor from the Console.

Seat Adjustment

Correct seat placement encourages exercise efficiency and comfort, while reducing the risk of injury.

1. With a Pedal in the forward position, place the heel of your foot to the lowest part of it. Your leg should be bent slightly at the knee.
2. If your leg is too straight or your foot cannot touch the Pedal, you need to move the seat downward. If your leg is bent too much, you need to move the seat upward.



Step off the machine before you adjust the seat.

3. Loosen and pull the Seat Post Adjustment Knob on the Seat Post. Adjust the seat to the desired height.



Do not lift the Seat post above the “STOP” mark on the Seat Post.

4. Release the Seat Post Adjustment Knob to engage the locking pin. Be sure that the pin is fully engaged and fully tighten the adjustment knob.
5. To move the seat closer to, or away from the console, loosen the Seat Slider Adjustment Handle. Slide the seat to the desired position and fully tighten the handle.

Note: If the handle cannot turn due to collision with another part, pull the handle, turn and push it back in to reposition it. Continue turning as needed.

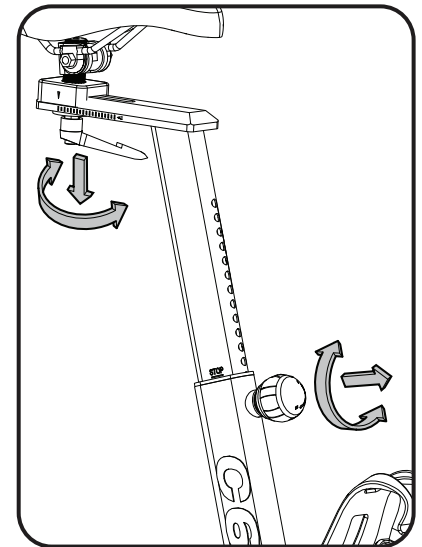

Foot Position / Pedal Strap Adjustment

Foot pedals with straps provide secure footing to the exercise bike.

1. Put the ball of each foot in the Foot Restraint on the Pedals.
2. Fasten the strap over the shoe.
3. Repeat for the other foot.

Be sure toes and knees point directly forward to ensure maximum Pedal efficiency. Pedal straps can be left in position for subsequent workouts.

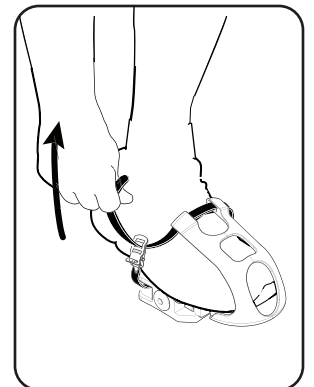

Shoe Clips (Cleats)

Foot pedals that are equipped for cycling shoes with cleats provide secure footing on the exercise bike. The shoe cleats provided fit both the right and left Pedals.



Prior to use, make sure you understand the operation of the engagement / release mechanism for the pedals and cleats (shoes).

Keep cleats and bindings clear of dirt and debris to ensure engagement and release.

Check the cleats periodically for wear. When the cleats are worn, replace them. Replace the cleat when it becomes difficult to release, or starts to release with much less effort than when it was in new condition.

Pedals and cleats are SPD Compatible. They fit any shoe size with the correct cleat mounts: shoes with "Standard 2-Hole MTB SPD Cleat Mounts" (MTB SPD = Mountain Bike Shimano Pedaling Dynamics).

1. Be sure that the arrow on top of the Pedal points forward.
2. Push the cleat down and forward to engage the Pedal.
3. Repeat for the other foot.
4. Practice engaging and disengaging from the Pedals before starting your workout.

To disengage (release) the cleats from the pedals, push the heels outward and lift.

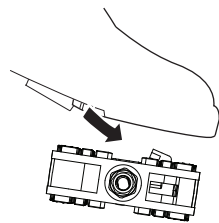

Engage

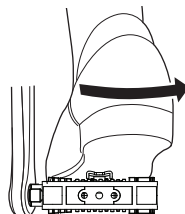

Disengage (release)

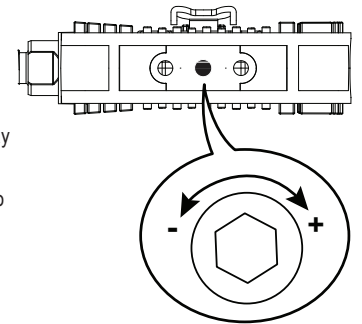

If the body weight of a user is very low, the user may have difficulty with operation of the engagement/release mechanism in the Pedals. It may be necessary to decrease the retention force of the mechanism. To adjust the retention:

1. Locate the opening in the rear of the Pedal for access to the adjustment bolt. It is between the 2 screws that attach the Foot Restraint to the Pedal.
2. Use a 3mm hex wrench to turn the adjustment bolt. To decrease the retention, turn it left (counterclockwise). To increase the retention, turn it right (clockwise).

Handlebar Adjustment

To adjust the handlebar position:

1. Loosen the Handlebar Post Adjustment Knob on the Handlebar Post. Adjust the Handlebar to the desired height.



Do not lift the Handlebar Post above the "STOP" mark on the Handlebar Post.

2. Tighten the Handlebar Post Adjustment Knob to engage the locking pin. Be sure that the pin is fully engaged and fully tighten the adjustment knob.

NOTICE: Do not crimp the cables.

3. To move the Handlebar closer to, or away from the seat, loosen the Handlebar Slider Adjustment Handle. Slide the Handlebar to the desired position and fully tighten the handle.

Note: If the handle cannot turn due to collision with another part, pull the handle, turn and push it back in to reposition it. Continue turning as needed.

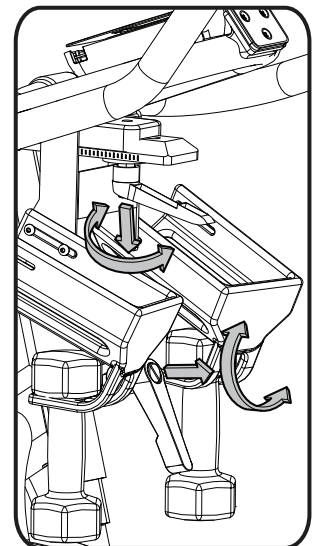

Locking the Flywheel for Storage

When the machine is not in use, be sure to lock the Flywheel with the Emergency Brake/Resistance Adjustment Knob. To lock the Flywheel, turn the Emergency Brake/Resistance Adjustment Knob clockwise until it encounters an increase in resistance. Then rotate the Emergency Brake/Resistance Adjustment Knob another 1/2 turn clockwise. The Flywheel is now locked. The flywheel should be locked for storage of the machine.



For safe storage of the machine, remove the power supply and place in a secure location. Tighten the Brake/Resistance Adjustment Knob as described until the Flywheel is locked. Place the machine in a secure location away from children and pets.

With the Flywheel locked, the level of resistance will be out of the range of operation displayed by the Console. Do not use the machine with the level of resistance outside of the 0% - 100% range. This will damage the ability to quickly stop the Flywheel during an emergency, and the effectiveness of securing the bike for storage. Turn the Emergency Brake/Resistance

Adjustment Knob until the LEVEL displayed on the Console is less than 100%. The resistance is now in the designed range of operation for the bike.

Power-Up Mode

The Console will enter Power-Up Mode if any button is pushed, or if it receives a signal from the RPM sensor as a result of pedaling.

Auto Shut-Off (Sleep Mode)

If the Console does not receive any input in approximately 5 minutes, it will automatically shut off. The LCD display is off while in Sleep Mode.

Note: The Console does not have an On/Off switch.

Resistance Adjustment

To increase the resistance and workload, turn the resistance adjustment knob clockwise. To reduce the resistance, turn the resistance adjustment knob counter-clockwise. The range of movement of the Resistance Adjustment Knob is 0% to slightly past the 100% level of resistance (locked Flywheel). Do not turn the Resistance Adjustment Knob past the range of movement. If turned past the range of movement, damage to the machine may occur.

Starting a Workout

1. Push the START/ENTER button. The Console will display the Time value.
2. Push the Increase / Decrease buttons to modify the Time value of the workout. When done, push the START/ENTER button.
3. The Console will display the Calories value. Push the Increase / Decrease buttons to modify the Calories value. When done, push the START/ENTER button.
4. The Console will display the Distance value. Push the Increase / Decrease buttons to modify the Distance value. When done, push the START/ENTER button.
5. The Workout will begin.

Changing Unit Measures (English Imperial/Metric)

The units of measurement can be switched between kilometers and miles before you start a workout. To change the units, push UP and DOWN together and hold 3 seconds. When the display begins to blink, use the arrow button to change the units (KM or MI). Push any button to save.

Pausing or Stopping

1. Stop pedaling to pause your workout. The Console will pause the workout if there is no RPM signal for 2 seconds.
2. To continue your workout, start pedaling.

The workout will end after being paused for 5 minutes.

When paused, the Console display will display the current workout values for the workout. To end the paused workout, push and hold down the Reset button.

Maintenance

Read all maintenance instructions fully before you start any repair work. In some conditions, an assistant is required to do the necessary tasks.



Equipment must be regularly examined for damage and repairs. The owner is responsible to make sure that regular maintenance is done. Worn or damaged components must be repaired or replaced immediately. Only manufacturer supplied components can be used to maintain and repair the equipment.

If at any time the Warning labels become loose, unreadable or dislodged, replace the labels. If purchased in US/Canada, contact Customer Service for replacement labels. If purchased outside US/Canada, contact your local distributor for them.

Disconnect all power to the machine before you service it.

Daily:

Before each use, examine the exercise machine for loose, broken, damaged, or worn parts. Do not use if found in this condition. Repair or replace all parts at the first sign of wear or damage. Make sure adjustment knobs are tight. Tighten as necessary. After each workout, use a damp cloth to wipe your machine and Console free of moisture.

NOTICE: If necessary, only use a mild dish soap with a soft cloth to clean the Console. Do not clean with a petroleum based solvent, automotive cleaner, or any product that contains ammonia. Do not clean the Console in direct sunlight or at high temperatures. Be sure to keep the Console free of moisture.

Weekly:

Check crank arms and tighten as necessary.
Clean the machine to remove any dust, dirt, or grime from the surfaces.
Check for smooth seat operation. If needed, sparingly apply a thin coating of silicone lube to ease operation.



Silicone lubricant is not intended for human consumption. Keep out of reach of children. Store in a safe place.

Note: Do not use petroleum based products.

**Monthly
or after 20 hours:**

Check crank arms and tighten as necessary. Make sure all bolts and screws are tight. Tighten as necessary.
Check the drive belt tension and adjust if necessary.

Checking the Drive Belt Tension

To check the Drive Belt tension, the bike needs to be operated. Get the pedals rotating at about 20 RPM. Then suddenly increase the RPM to your maximum ability. If the pedals move normally with no slipping, the tension is correct. If the Pedals slip, the belt needs to be adjusted.

Adjusting the Drive Belt Tension

1. To change the tension of the Drive Belt, loosen the Axle Nuts. Use a 15mm open end wrench to hold the Axle Nut on one side steady, and loosen the Axle Nut on the opposite side with a 15mm socket and wrench.
2. If the Drive Belt is too loose and slipping, use a 10mm wrench to turn each Flywheel Retainer Nut a 1/4 turn to the right (clockwise).
3. Re-test the tension of the Drive Belt, and adjust if still necessary.

A detailed "Adjust the Belt Tension" procedure can be found in the Service Manual.

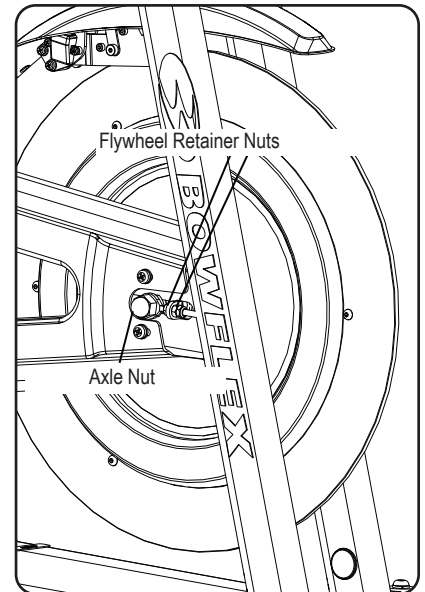

(If purchased in US/Canada) Warranty

Who Is Covered

This warranty is valid only to the original purchaser and is not transferable or applicable to any other person(s).

What Is Covered

Nautilus, Inc. warrants that this product is free from defects in materials and workmanship, when used for the purpose intended, under normal conditions, and provided it receives proper care and maintenance as described in the Product's Assembly and Owner's manual. This warranty is good only for authentic, original, legitimate machines manufactured by Nautilus, Inc. and sold through an authorized agent and used in the United States or Canada.

Terms

Warranty terms for products purchased in US/Canada are as stated below

- Frame 10 years
- Mechanical parts 3 years
- Electronics 3 years
- Labor 1 year

(Labor support does not include the installation of replacement parts involved in the initial product assembly and preventative maintenance services.)

For warranty & service of products purchased outside US/Canada, please contact your local distributor. To find your local international distributor, go to: www.nautilusinternational.com

How Nautilus Will Support the Warranty

Throughout the terms of the warranty coverage, Nautilus, Inc. will repair any machine that proves to be defective in materials or workmanship. Nautilus reserves the right to replace the product in the event a repair is not possible. When Nautilus determines replacement is the correct remedy, Nautilus may apply a limited credit reimbursement toward another Nautilus, Inc. brand Product, at our discretion. This reimbursement may be prorated based on length of ownership. Nautilus, Inc. provides repair service within major metropolitan areas. Nautilus, Inc. reserves the right to charge the consumer for travel outside these areas. Nautilus, Inc. is not responsible for dealer labor or maintenance charges beyond the applicable warranty period(s) stated herein. Nautilus, Inc. reserves the right to substitute material, parts or products of equal or better quality if identical materials or products are not available at the time of service under this warranty. Any replacement of the product under the terms of the Warranty in no way extends the original Warranty period. Any limited credit reimbursement may be prorated based on length of ownership. THESE REMEDIES ARE THE EXCLUSIVE AND SOLE REMEDIES FOR ANY BREACH OF WARRANTY.

What You Must Do

- Retain appropriate and acceptable Proof of Purchase.
- Operate, maintain, and inspect the Product as specified in the Product Documentation (Assembly, Owner's Manuals, etc.).
- Product must be used exclusively for the purpose intended.
- Notify Nautilus within 30 days after detecting an issue with the Product.
- Install replacement parts or components in accordance with any Nautilus instructions.
- Perform diagnostic procedures with a trained Nautilus, Inc representative if requested.

What Is Not Covered

- Damage due to abuse, tampering or modification of the Product, failure to properly follow assembly instructions, maintenance instructions, or safety warnings as stated in the Product Documentation (Assembly, Owner's Manuals, etc), damage due to improper storage or the effect of environmental conditions such as moisture or weather, misuse, mishandling, accident, natural disasters, power surges.
- A machine placed or used in a commercial or institutional setting. This includes gyms, corporations, work places, clubs, fitness centers and any public or private entity that has a machine for use by its members, customers, employees or affiliates.
- Damage caused by exceeding maximum user weights as defined in the Product's Owner's manual or warning label.
- Damage due to normal usage and wear and tear.
- This warranty does not extend to any territories or countries outside the United States and Canada.

How to Obtain Service

For Products purchased directly from Nautilus, Inc. contact the Nautilus office listed on the Contacts page of the products Owner's manual. You may be required to return the defective component to a specified address for repair or inspection, at your expense. Standard ground shipping of any warranty replacement parts will be paid by Nautilus, Inc. For products purchased from a retailer, you may be asked to contact your retailer for warranty support.

Exclusions

The preceding warranties are the sole and exclusive express warranties made by Nautilus, Inc. They supersede any prior, contrary or additional representations, whether oral or written. No agent, representative, dealer, person or employee has the authority to alter or increase the obligations or limitations of this warranty. Any implied warranties, including the WARRANTY OF MERCHANTABILITY and any WARRANTY OF FITNESS FOR A PARTICULAR PURPOSE, are limited in duration to the term of the applicable express warranty provided above, whichever is longer. Some states do not allow limitations on how long an implied warranty lasts, so the above limitation may not apply to you.

Limitation of Remedies

EXCEPT AS OTHERWISE REQUIRED BY APPLICABLE LAW, THE PURCHASER'S EXCLUSIVE REMEDY IS LIMITED TO REPAIR OR REPLACEMENT OF ANY COMPONENT DEEMED BY NAUTILUS, INC. TO BE DEFECTIVE UNDER THE TERMS AND CONDITIONS STATED HEREIN. IN NO EVENT WILL NAUTILUS, INC. BE LIABLE FOR ANY SPECIAL, CONSEQUENTIAL, INCIDENTAL, INDIRECT OR ECONOMIC DAMAGES, REGARDLESS OF THE THEORY OF LIABILITY (INCLUDING, WITHOUT LIMITATION, PRODUCT LIABILITY, NEGLIGENCE OR OTHER TORT) OR FOR ANY LOST REVENUE, PROFIT, DATA, PRIVACY OR FOR ANY PUNITIVE DAMAGES ARISING OUT OF OR RELATED TO THE USE OF THE FITNESS MACHINE EVEN IF NAUTILUS, INC. HAS BEEN ADVISED OF THE POSSIBILITY OF SUCH DAMAGES. THIS EXCLUSION AND LIMITATION SHALL APPLY EVEN IF ANY REMEDY FAILS OF ITS ESSENTIAL PURPOSE. SOME STATES DO NOT ALLOW THE EXCLUSION OR LIMITATION OF CONSEQUENTIAL OR INCIDENTAL TYPE DAMAGES SO THE ABOVE LIMITATION MAY NOT APPLY TO YOU.

State Laws

This warranty gives you specific legal rights. You may also have other rights, which vary from state to state.

Expirations

If the warranty has expired, Nautilus, Inc. may assist with replacements or repairs to parts and labor, but there will be a charge for these services. Contact a Nautilus office for information on post-warranty parts and services. Nautilus does not guarantee availability of spare parts after expiration of warranty period.

International Purchases

If you purchased your machine outside of the United States consult your local distributor or dealer for warranty coverage.

