

**BOWFLEX**

# TreadClimber<sup>®</sup> TC100

ASSEMBLY / OWNER'S MANUAL



Manual en Español  
Latino Americano:  
[www.support.nautilus.com](http://www.support.nautilus.com)

# Welcome to the Bowflex® TreadClimber® cardio machine!

You're about to experience an incredible workout that can help you lose weight and reshape your entire body so you'll look and feel better than ever before. We thank you for trusting in the Bowflex brand. We're so confident in your purchase that we guarantee results. If you don't see results in the first six weeks, you can get your money back (less shipping and handling) – guaranteed (see "Buy Back Guarantee").

Use this Manual as a guide to getting started on your TreadClimber™ workouts and for tips to keep your machine well maintained.

Yours in Health,  
The Bowflex Family

## Table of Contents

Important Safety Instructions .....	3	Initial Setup .....	40
Safety Warning Labels and Serial Number.....	6	User Profiles .....	40
Grounding Instructions .....	7	Workout Program .....	41
Emergency Stop Procedure .....	7	Fitness Score Display.....	41
Specifications / Before Assembly .....	8	Pausing or Stopping .....	43
Parts .....	9	Awards .....	43
Hardware / Tools .....	10	Workout Complete / Results .....	43
Assembly .....	11	Machine Settings Mode .....	44
Moving Your Machine .....	24	Maintenance.....	45
Leveling Your Machine .....	24	Walking Belt Alignment.....	47
Features .....	25	Troubleshooting.....	50
Fitness Basics .....	32	Body Weight Loss Guide.....	52
Operations.....	39	Buy Back Guarantee .....	62
Before You Start .....	39	Warranty.....	63
Power Up / Idle Mode .....	39		

To validate warranty support, keep the original proof of purchase and record the following information:

Serial Number \_\_\_\_\_ Date of Purchase \_\_\_\_\_

To register your product warranty, go to: [www.bowflex.com/register](http://www.bowflex.com/register)

Or call 1 (800) 605-3369.

If you have questions or problems with your product, please call 1 (800) 605-3369.

Nautilus, Inc., (800) 605-3369, [www.NautilusInc.com](http://www.NautilusInc.com) - Customer Service: North America (800) 605-3369, [csnls@nautilus.com](mailto:csnls@nautilus.com) | outside U.S. [www.nautilusinternational.com](http://www.nautilusinternational.com) | Printed in China | © 2015 Nautilus, Inc. | ® indicates trademarks registered in the United States. These marks may be registered in other nations or otherwise protected by common law. Bowflex, the B logo, TreadClimber, Bowflex Body, Easy Step, Bowflex Trainer, Nautilus, Schwinn, and Universal are trademarks owned by or licensed to Nautilus, Inc. MyFitnessPal®, WD-40®, Lube-N-Walk®, and Nut Thins® are trademarks of their respective owners.

# Important Safety Instructions

When using an electrical appliance, basic precautions should always be followed, including the following:



This icon means a potentially hazardous situation which, if not avoided, could result in death or serious injury.

Obey the following warnings:



Read and understand all Warnings on this machine.

Carefully read and understand the Assembly/Owner's Manual.



**Carefully read and understand the Assembly instructions. Read and understand the complete Manual. Keep the Manual for future reference.**



**To reduce the risk of electrical shock or unsupervised usage of the equipment, always unplug this machine from the electrical outlet immediately after using and before cleaning.**



**To decrease the risk of burns, electric shock, or injury to persons, read and understand the complete Assembly/Owner's Manual. Failure to follow these guidelines can cause a serious or possibly fatal electrical shock or other serious injury.**

- Keep bystanders and children away from the product you are assembling at all times.
- Do not connect power supply to the machine until instructed to do so.
- The machine should never be left unattended when plugged in. Unplug from outlet when not in use, and before putting on or taking off parts.
- Before each use, examine the machine for damage to power cord, loose parts or signs of wear. Do not use if found in this condition. Contact Nautilus Customer Service for repair information.
- Not intended for use by persons with medical conditions where those conditions may impact the safe operation of the machine or pose a risk of injury to the user.
- Do not drop or put objects into any opening of the machine.
- Never operate this machine with the air openings blocked. Keep the air openings free of lint, hair and the like.
- Do not assemble this machine outdoors or in a wet or moist location.
- Make sure assembly is done in an appropriate work space away from foot traffic and exposure to bystanders.
- Some components of the machine can be heavy or awkward. Use a second person when doing the assembly steps involving these parts. Do not do steps that involve heavy lifting or awkward movements on your own.
- Set up this machine on a solid, level, horizontal surface.
- Do not try to change the design or functionality of this machine. This could compromise the safety of this machine and will void the warranty.
- If replacement parts are necessary, use only genuine replacement parts and hardware supplied by Nautilus. Failure to use genuine replacement parts can cause a risk to users, keep the machine from operating correctly and void the warranty.
- Do not use until the machine has been fully assembled and inspected for correct performance in accordance with the Owner's Manual.
- Do all assembly steps in the sequence given. Incorrect assembly can lead to injury or malfunctioning of the machine.
- Connect this machine to a properly grounded outlet only (see Grounding Instructions).
- Keep the power cord away from heat sources and hot surfaces.
- Do not operate where aerosol products are being used.
- To disconnect, turn all controls to the off position, then remove plug from outlet.
- This product contains magnets. Magnetic fields can interfere with the normal use of certain medical devices at a close range. Users may come into proximity of the magnets in the assembly, maintenance, and/or use of the product. Given the obvious importance of these devices, such as a pacemaker, it is important that you consult with your medical provider in connection with the use of this equipment. Please consult the "Safety Warning Labels and Serial Number" section to determine the location of the magnets on this product.
- SAVE THESE INSTRUCTIONS.

Before using this equipment, obey the following warnings:



**Read and understand the complete Owner's Manual. Keep the Owner's Manual for future reference.**

Read and understand all Warnings on this machine. If at any time the Warning stickers become loose, unreadable or dislodged, contact Nautilus Customer Service for replacement stickers.



**To reduce the risk of electrical shock or unsupervised usage of the equipment, always unplug the power cord from the wall outlet and/or the machine and wait 5 minutes before cleaning, maintaining or repairing the machine. Place the power cord in a secure location.**

- Children must not be let on or near to this machine. Moving parts and other features of the machine can be dangerous to children.
- Not intended for use by anyone under 14 years of age.
- Consult a physician before you start an exercise program. Stop exercising if you feel pain or tightness in your chest, become short of breath, or feel faint. Contact your doctor before you use the machine again. Use the values calculated or measured by the machine's computer for reference purposes only.
- Before each use, examine this machine for damage to power cord, power receptacle, loose parts or signs of wear. Do not use if found in this condition. Contact Nautilus Customer Service for repair information.
- Always connect the power cord to a circuit capable of handling 10 amperes with no other loads applied.
- Connect this machine to a correctly grounded outlet; consult a licensed electrician for assistance.
- Do not let liquids touch the electronic controller. If it does, the controller must be inspected and tested for safety by an approved technician before it can be used again.
- The electrical wiring for the residence in which the machine will be used must obey the applicable local and provincial requirements.
- Maximum user weight limit: 300 lbs. (136 kg). Do not use if you are over this weight.
- This machine is for home use only.
- Do not wear loose clothing or jewelry. This machine contains moving parts. Do not put fingers, feet, or other objects into moving parts of the exercise equipment.
- Always wear rubber soled athletic shoes when you use this machine. Do not use the machine with bare feet or only wearing socks.
- Because of how the Treadles and Walking Belts operate, it is possible for extremely light-weight, flexible shoes, or minimalist shoes, to be caught. Only wear athletic shoes that have more toe protection, structure, and support. Light-weight or minimalist shoes should not be worn.
- Set up and operate this machine on a solid, level, horizontal surface.
- Use caution when you step on and off the machine. Use the supplied foot support platforms for stability before walking on the moving belt.
- The normal design and operation of this machine allows for the treadles to move independently of each other when a person steps on, or exerts force or pressure, on the treadles. Be aware that treadle movement can occur when the machine is unplugged or the safety key removed. Always take care to insure that fingers do not get caught between the treadles, and to prevent injury never allow children or pets around the machine.
- Do not operate this machine outdoors or in moist or wet locations.
- Keep at least 19.5" (1/2 m) on each side of the machine and 79" (2 m) behind the machine clear. This is the recommended safe distance for access and passage around and emergency dismounts from the machine. Keep third parties out of this space when machine is in use.
- Do not over exert yourself during exercise. Operate the machine in the manner described in this manual.
- Perform all regular and periodic maintenance procedures recommended in the Owner's Manual.
- Read, understand, and test the Emergency Stop Procedure before use.
- Keep the walking belt clean and dry.
- Do not drop or put objects into any opening of the machine.
- This machine is designed for walking. Do not try to run on this machine.
- Keep your hands on the support Handlebars and stay as near the front of the machine as is comfortable in order to stay in balance on the Treadles.
- Keep your foot in the center of each Treadle, do not let your feet cross in front of your body as you increase the speed.

- The electrical wiring for the residence in which the machine will be used must obey the applicable local and provincial requirements.
- Exercise on this machine requires coordination and balance. Be sure to anticipate that changes in speed, the angle of Walking Decks, and resistance level can occur during workouts, and be attentive in order to avoid loss of balance and possible injury.
- A machine should never be left unattended when plugged in. Unplug from outlet when not in use, and before putting on or taking off parts.
- Use this machine only for its intended use as described in this manual. Do not use attachments not recommended by the manufacturer.
- This appliance is not intended for use by persons with reduced physical, sensory or mental capabilities, or lack of knowledge, unless they have been given supervision or instruction concerning use of the appliance by a person responsible for their safety. Keep children under the age of 14 away from this machine.

# Safety Warning Labels and Serial Number

## CAUTION

Risk of Injury to Persons - To Avoid injury, use extreme caution when stepping onto or off of a moving belt. Read instruction manual before using.

## WARNING!

- Prior to use, read and understand the Owner's Manual, including all Warnings.
- Inspect product before use. Do not use if any parts are in need of repair.
- Keep children and pets away from this machine at all times.
- Not intended for use by anyone under 14 years of age.
- This machine is for home use only.
- Use caution when you use this equipment or serious injury can occur.
- To prevent injury, stand on the Foot Platforms before you start the machine.
- The maximum user weight for this machine is 136kg ( 300 lb ).
- Replace any "Caution" "Warning" or "Danger" label that is illegible, damaged, or removed.
- The heart rate displayed on the console is an approximation and should be used for reference only.
- When this machine is not in operation, remove the Safety Key and keep out of the reach of children.

## CAUTION

Unplug power cord before you move the machine.

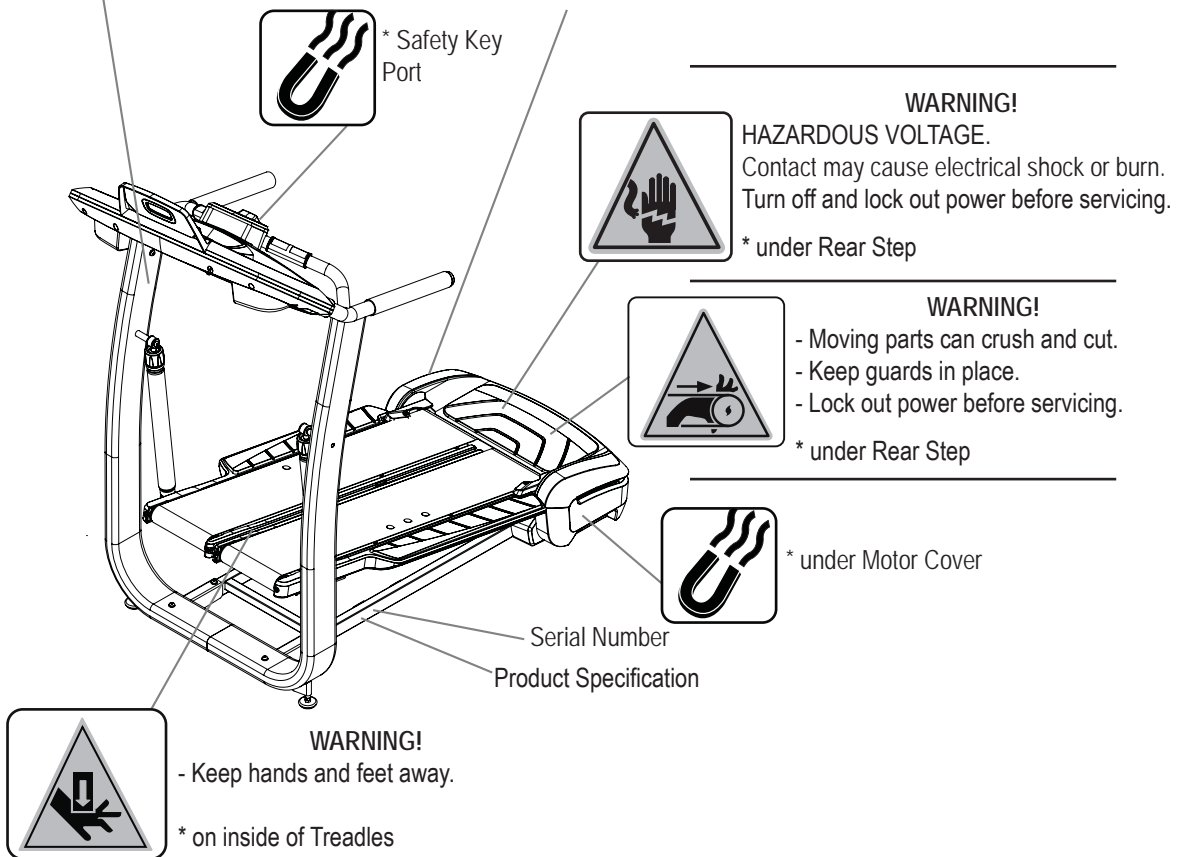

## Grounding Instructions

This product must be electrically grounded. If a malfunction occurs, correct grounding decreases the risk of electric shock. The power cord is equipped with an equipment-grounding conductor, and must be connected to an outlet that is properly installed and grounded.

**⚠ DANGER** The electrical wiring must comply with all applicable local and provincial standards and requirements. Incorrect connection of the equipment-grounding conductor can result in a risk of electric shock. Consult a licensed electrician if you are not sure that the machine is correctly grounded. Do not change the plug on the machine – if it does not fit the outlet, have a correct outlet installed by a licensed electrician.

If you connect the machine to an outlet with GFI (ground fault interrupt) or AFCI (arc fault circuit interrupt), machine operation can cause the circuit to trip.

**⚠** If an extension cord or surge protector is used with this machine, make sure that it is a heavy duty model rated at 15A operation, and accepts an equipment-grounding conductor. Do not connect other appliances or devices to the extension cord or surge protector in combination with this machine.

This machine is for use on a nominal 120-V circuit, and has a grounding plug that looks like the plug illustrated below. Make sure that the product is connected to an outlet having the same configuration as the plug. No adapter should be used with this product.

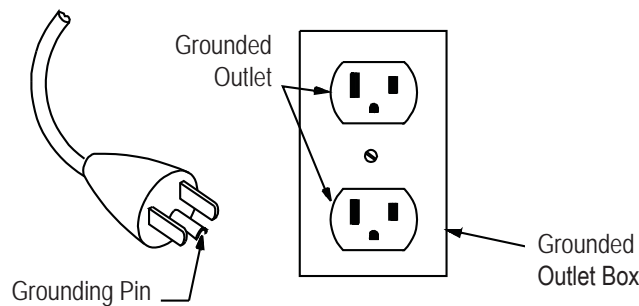

## Emergency Stop Procedure ( Safety Key Port )

The TreadClimber® machine is equipped with a Safety Key that can prevent serious injury, unsupervised operation, as well as prevent children from playing with and/or being injured on the machine. If the Safety Key is removed or not correctly inserted into the Safety Key Port, the belts will not operate.

**⚠** Always attach the Safety Key Clip to your clothing during your workout.

When you use the machine, only remove the Safety Key in an emergency. When the key is removed while the machine is in operation, it will stop quickly, which could cause the loss of balance and possible injury.

For safe storage of the machine and to prevent unsupervised operation of the machine always remove the Safety Key and disconnect the power cord from the wall outlet and machine AC input. Place the power cord in a secure location.

The Console will display “INSERT SAFETY KEY” when the Safety Key is not attached. The TreadClimber® machine will end a workout program when the Safety Key is removed.

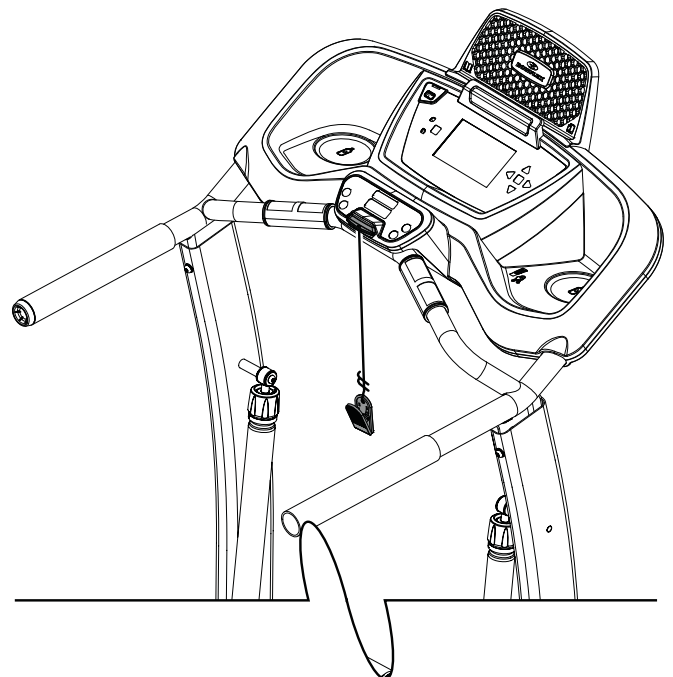



# Specifications / Before Assembly

<b>Maximum User Weight:</b>	300 lbs (136 kgs)
<b>Power Requirements:</b>	
Operational Voltage:	120VAC 60Hz
Operating Current:	6.5A max
<b>Regulatory Approvals:</b>	cULus mark. Evaluated per UL1647 Fifth Edition and CAN/CSA-C22.2. No. 68-09
<b>Maximum Inclined Treadle Height:</b>	14.5 inches ( 36.8 cm)
<b>Assembled Weight:</b>	approx. 158 lbs (71.8 kg)

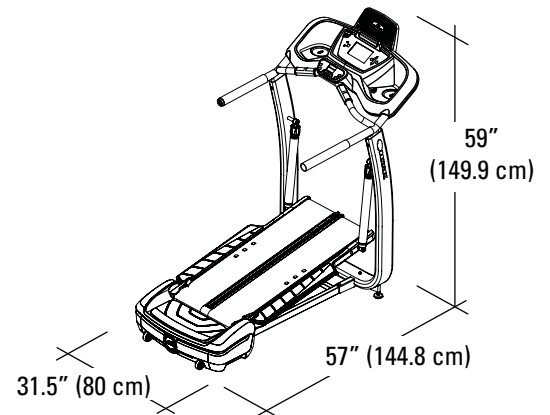

## Before Assembly

Select the area where you are going to set up and operate your machine. For safe operation, the location must be on a hard, level surface. Allow a minimum workout area of 70.5" x 136" (179.1 cm x 345.4 cm). Be sure that the workout space you are utilizing has adequate height clearance, taking into consideration the height of the user and the maximum inclined height of the treadles.

## Basic Assembly

Follow these basic points when you assemble your machine:

- Read and understand the "Important Safety Instructions" before assembly.
- Collect all the pieces necessary for each assembly step.
- Using the recommended wrenches, turn the bolts and nuts to the right (clockwise) to tighten, and the left (counterclockwise) to loosen, unless instructed otherwise.
- When attaching 2 pieces, lightly lift and look through the bolt holes to help insert the bolt through the holes.
- The assembly requires 2 people.
- Do not use any power tools for assembly.

**Note:** The TreadClimber® fitness machine is designed to plug into a grounded, non-GFI/non-AFCI outlet only. To determine if your outlet or circuit breaker is GFI/AFCI, look for a test and reset button on them. If they have the test and reset button, it is a GFI/AFCI outlet or circuit breaker.

## Machine Mat

The Bowflex™ TreadClimber™ Machine Mat is an optional accessory that helps keep your workout area clear and adds a layer of protection to your floor. The rubber machine mat provides a non-slip, rubber surface which limits static discharge and reduces the possibility of display errors. If possible, put your Bowflex™ TreadClimber™ Machine Mat in your selected workout area before you begin assembly.

To order the optional machine mat, go to: [www.bowflex.com](http://www.bowflex.com), or call 1 (800) 605-3369.



BOX 1

(2BOXES)

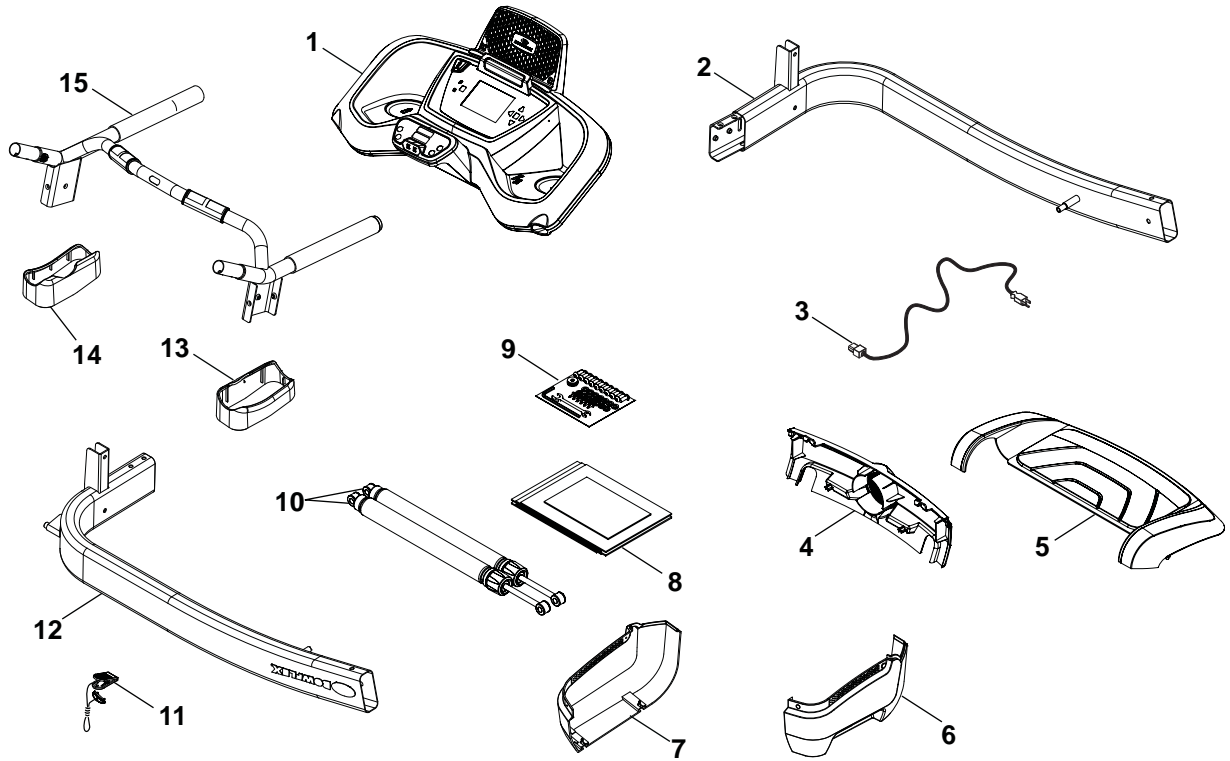

Item	Qty	Description	Item	Qty	Description
1	1	Console Assembly	9	1	Hardware Card
2	1	Upright, Left	10	2	Shock
3	1	Power Cord	11	1	Safety Key
4	1	Rear Cover	12	1	Upright, Right
5	1	Rear Step	13	1	Junction Cover, Left
6	1	Side Motor Cover, Right	14	1	Junction Cover, Right
7	1	Side Motor Cover, Left	15	1	Handlebar Assembly
8	1	Document Kit			

BOX 2

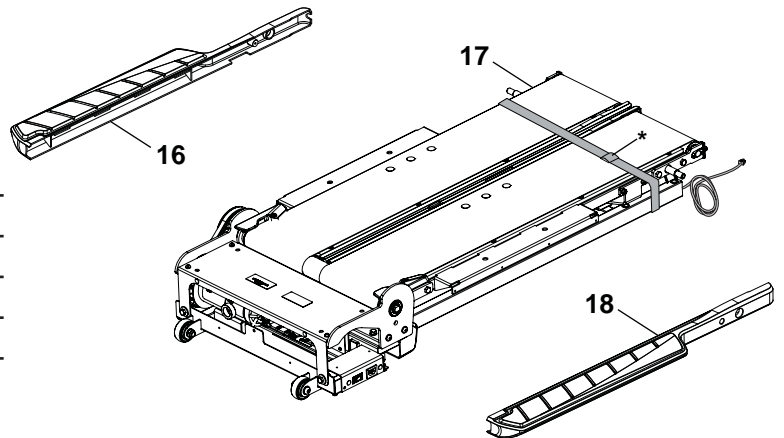

Item	Qty	Description
16	1	Foot Rail Cover, Left
17	1	Treadle Assembly ( * )
18	1	Foot Rail Cover, Right

**!** DO NOT CUT the Shipping Strap on the Treadle Assembly until instructed ( \* ).

# Hardware / Tools

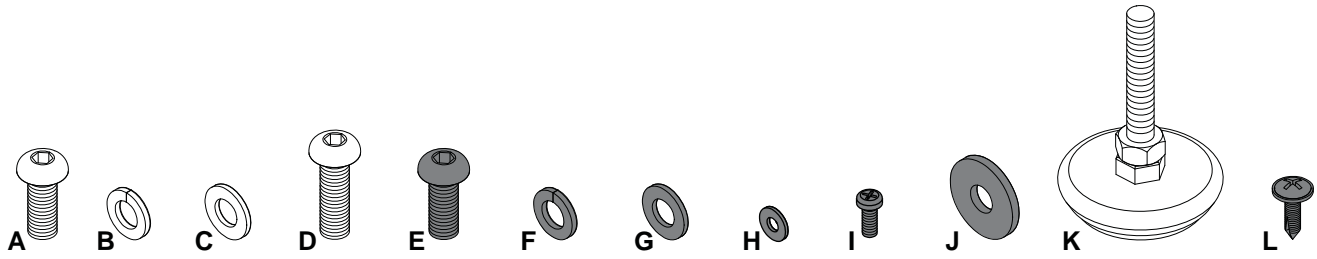

Item	Qty	Description	Item	Qty	Description
A	12	Button Head Hex Screw, M8x20	G	4	Flat Washer, M8 Black
B	14	Lock Washer, M8	H	10	Flat Washer, M4x10 Black
C	14	Flat Washer, M8	I	10	Phillips Screw, M4x12 Black
D	2	Button Head Hex Screw, M8x25	J	4	Flat Washer, M8 Wide Black
E	8	Button Head Hex Screw, M8x20 Black	K	2	Leveler
F	8	Lock Washer, M8 Black	L	6	Phillips Self Tapping Screw, M4x16 Black

Note: Select pieces of Hardware have been provided as spares on the Hardware Card. Be aware that there may be remaining Hardware after the proper assembly of your machine.

## Tools

### Included



5 mm



13 mm

### Not Included



#2



(recommended)

**!** Some components of the machine can be heavy or awkward. Use a second person when doing the assembly steps involving these parts. Do not do steps that involve heavy lifting or awkward movements on your own.

Note: This assembly uses parts of the packaging. Do not dispose of until assembly is complete.

## 1. Cut open the end of Box 2 and move the Treadle Assembly into your fitness area

Note: Do not crimp the I/O Cable.

Cut the Shipping Strap ( \* ) on the Treadle Assembly when it has been placed face up in the appropriate work space.

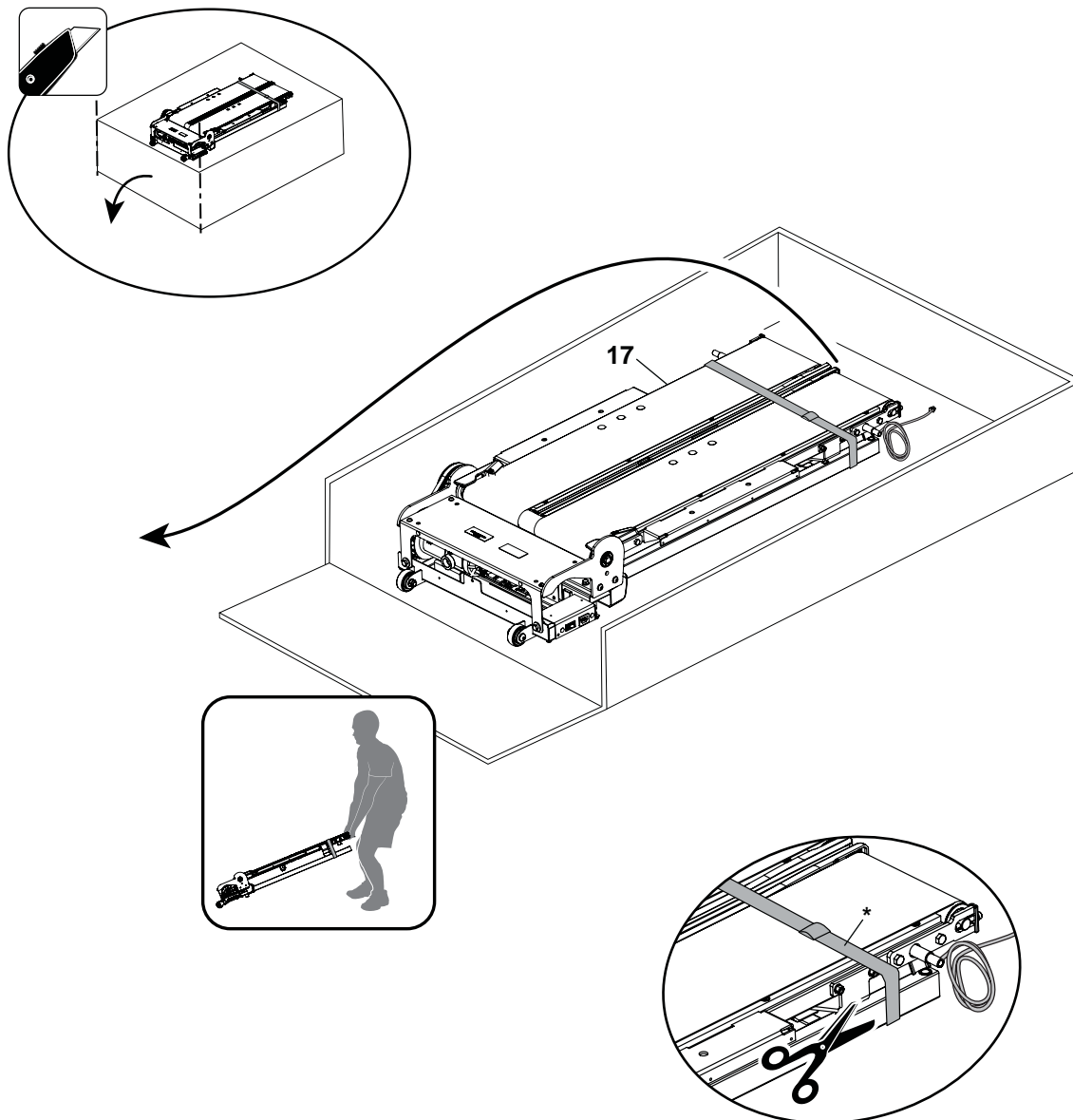

## 2. Slide Packaging Boxes under the Base of the Treadle Assembly and the Treadles

Note: Use the packaging materials for this step. The Base of the Treadle Assembly should be level, and the Treadles should be securely raised.

Boxes should not be in front of the crossbar.



The Treadles do not have a locking mechanism and must be supported safely.

**In order to avoid possible serious injury, when sliding the Packaging Boxes under the Treadle Assembly be careful to avoid fingers or hands being caught or pinched.**

Be aware that the Drive Belt and the Walking Belts are connected and when either of these parts move the other does as well. In order to avoid possible serious injury, do not allow anything to be caught or pinched by the Drive Belt when the Walking Belts are moved.

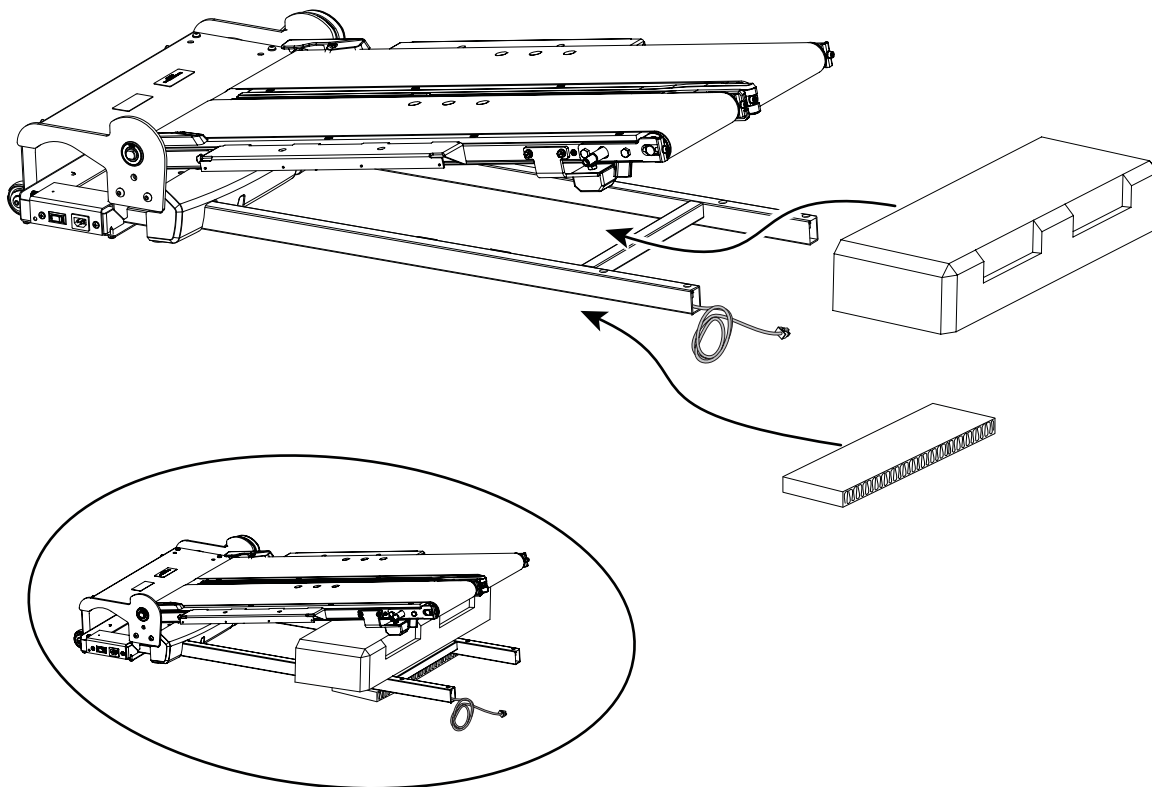

### 3. Attach the Left Upright to the Right Upright

Note: Hand tighten hardware.

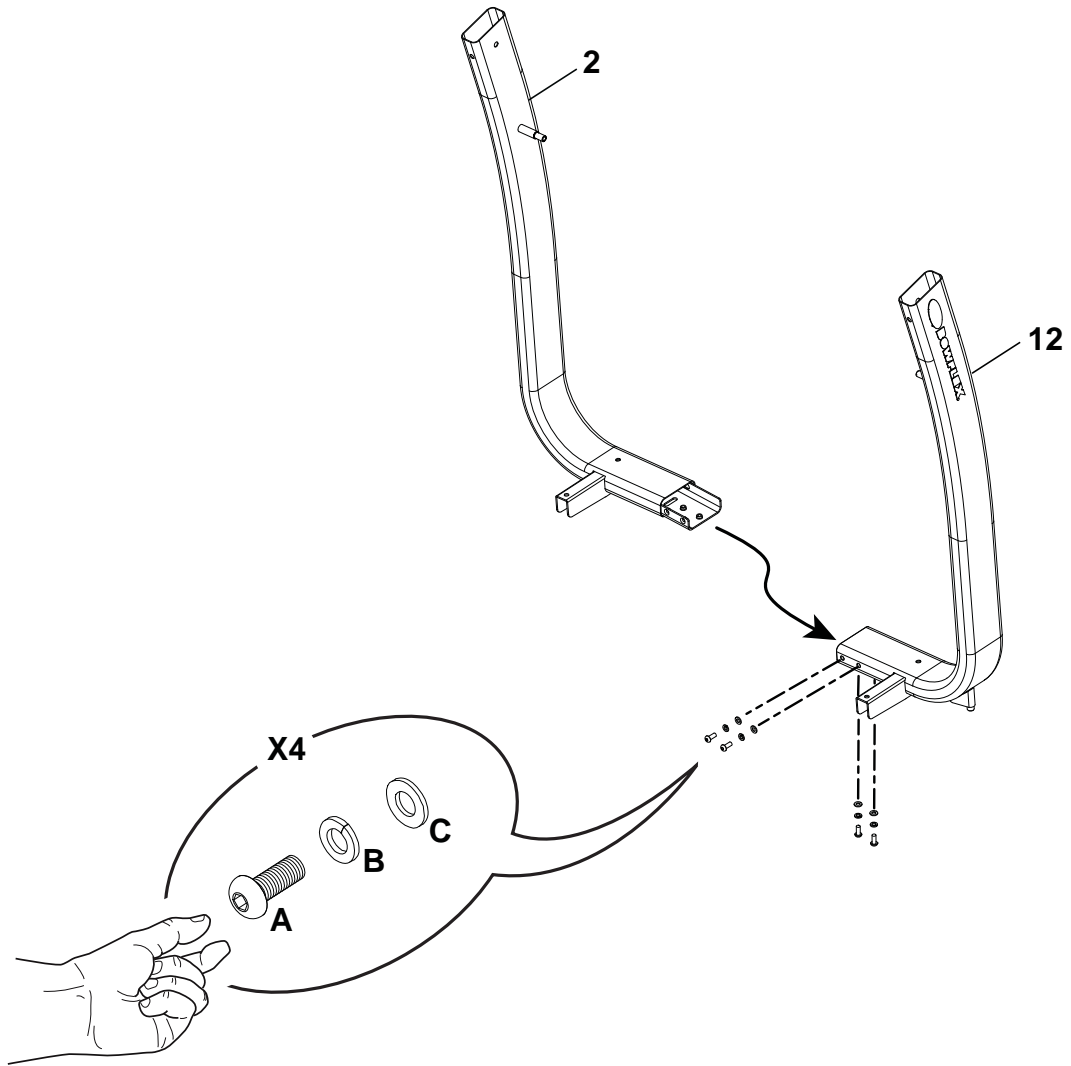

#### 4. Route the Lower I/O Cable through the Right Upright

Note: Do not crimp the Cable.

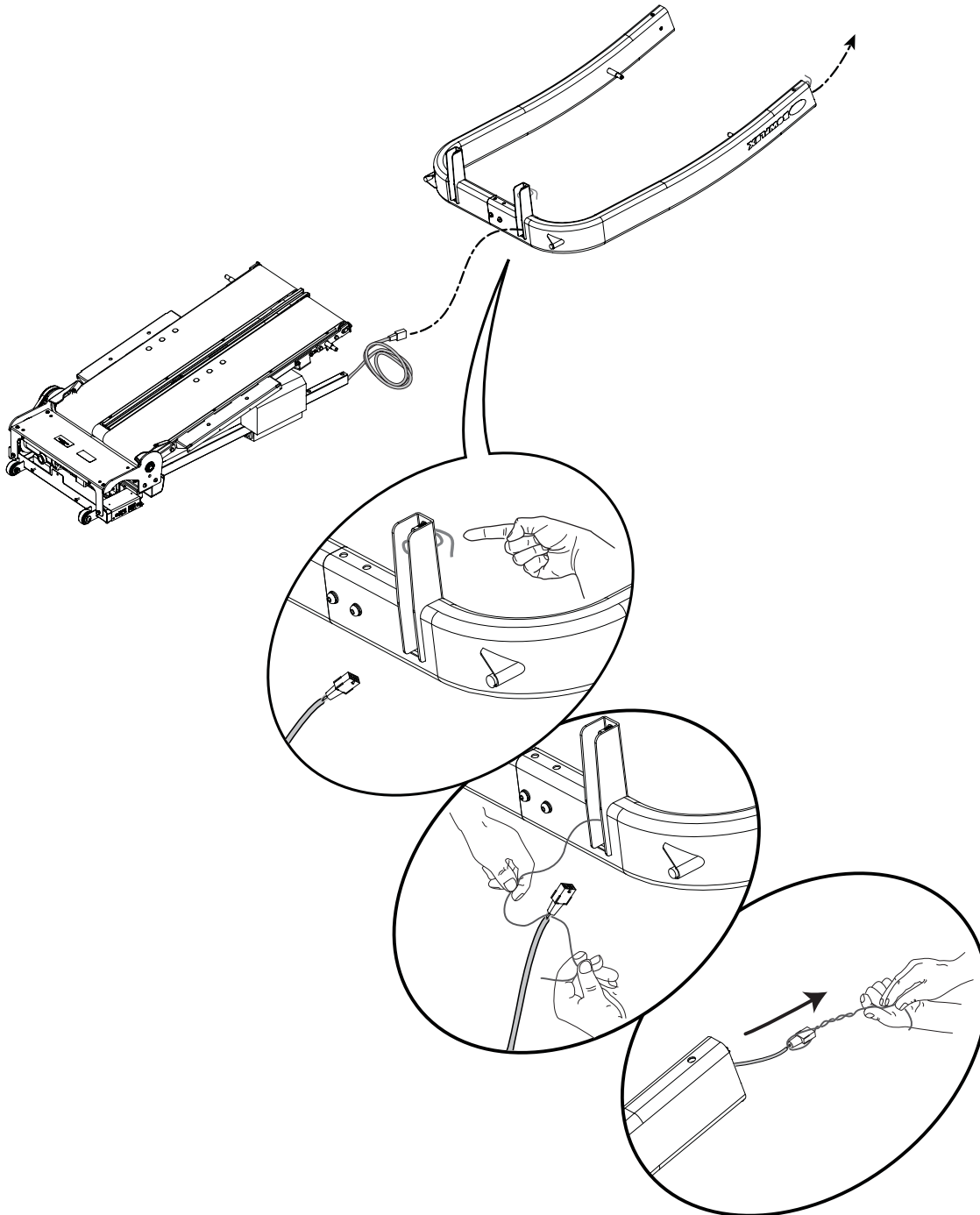

## 5. Attach the Upright Assembly to the Treadle Assembly

Note: Do not crimp the Cables.

**!** The Treadles do not have a locking mechanism and must be supported safely.

In order to avoid possible serious injury, when inserting the tube ends onto the Treadle Assembly be careful to avoid fingers or hands being caught or pinched. Be sure the excess length of the I/O Cable goes into the Upright and does not get crimped.

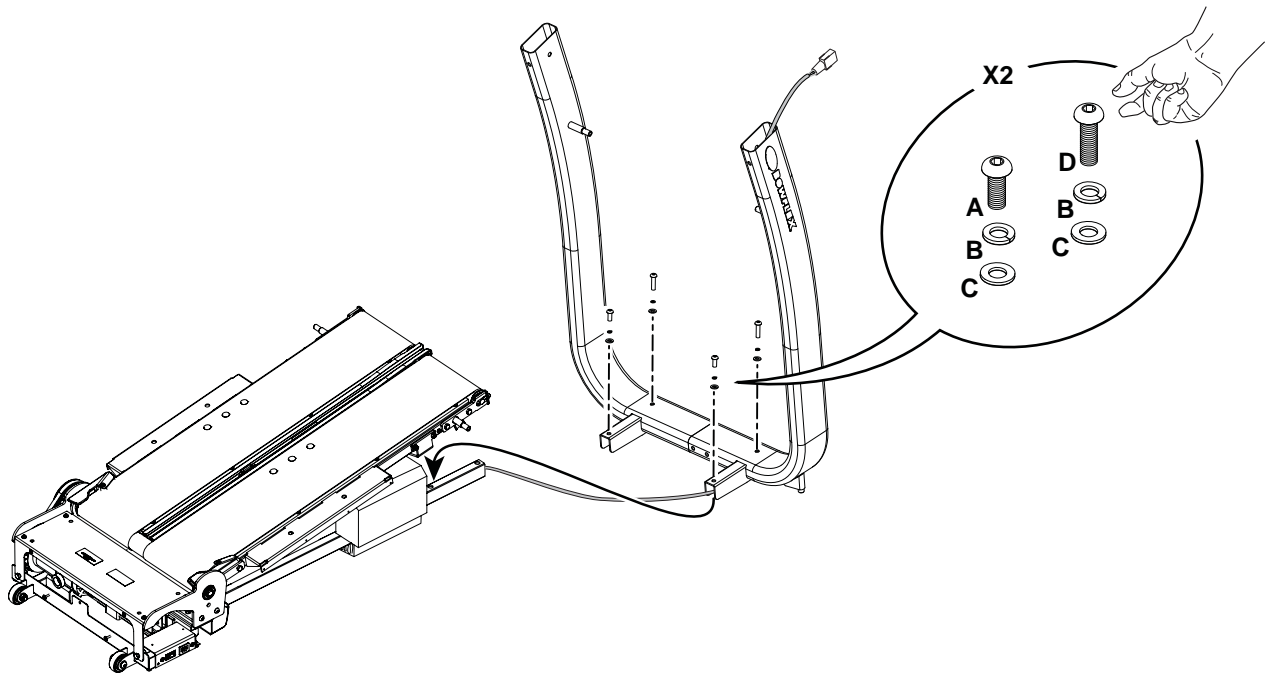



## 6. Route the Cables and Attach the Console Assembly to the Handlebar Assembly

Note: Do not crimp the Cables. Place a clean towel or blanket under the Console Assembly to protect it.

**!** In order to avoid possible serious injury, when inserting the tube ends into the Console Assembly be careful to avoid fingers or hands being caught or pinched.

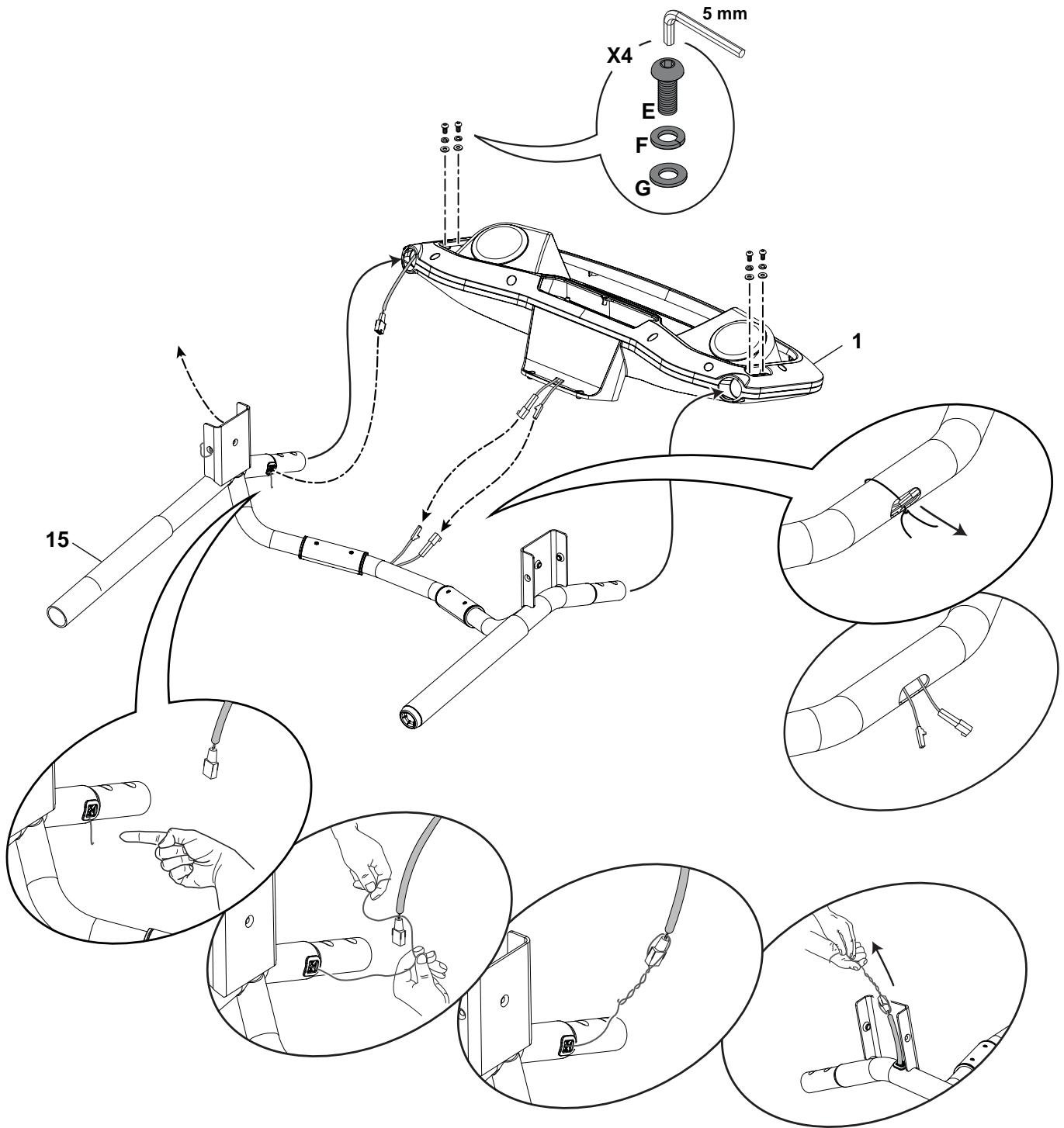

## 7. Place the Junction Covers on the Uprights, Connect the Cables, and Attach the Console / Handlebar Assembly

**!** In order to avoid possible serious injury, when inserting the tube ends onto the Uprights be careful to avoid fingers or hands being caught or pinched. Be sure the excess length of the I/O Cable goes into the Upright and does not get crimped.

Note: Do not crimp the Cables.

\* Hand tighten this hardware first until inner bolt holes align.

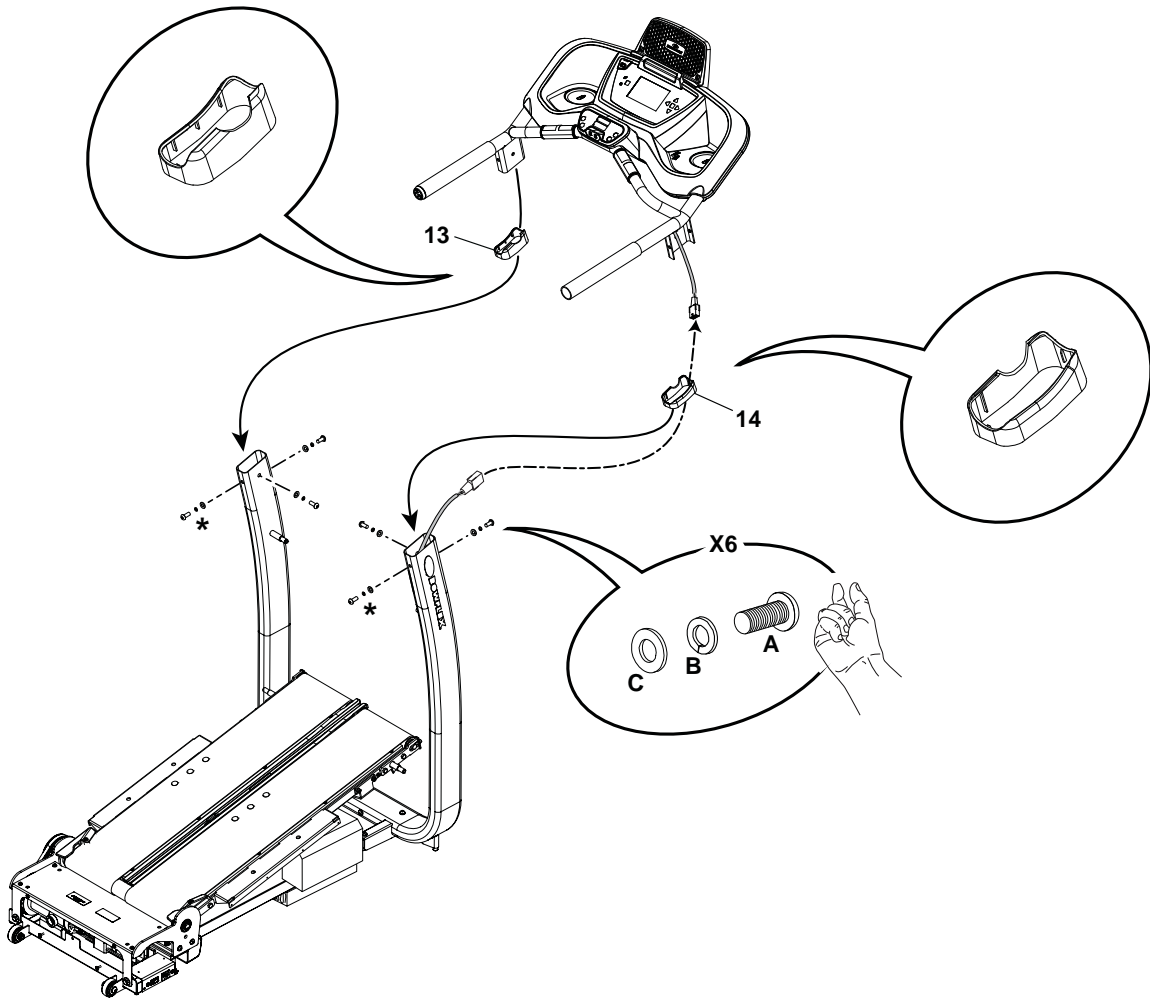

## 8. Attach the Foot Rail Covers to the Treadle Assembly

 The Walking Belts can abruptly move. To avoid possible serious injury, keep hands away from the edges of the Walking Belts.

Be aware that the Drive Belt and the Walking Belts are connected and when either of these parts move the other does as well. In order to avoid possible serious injury, do not allow anything to be caught or pinched by the Drive Belt when the Walking Belts are moved.

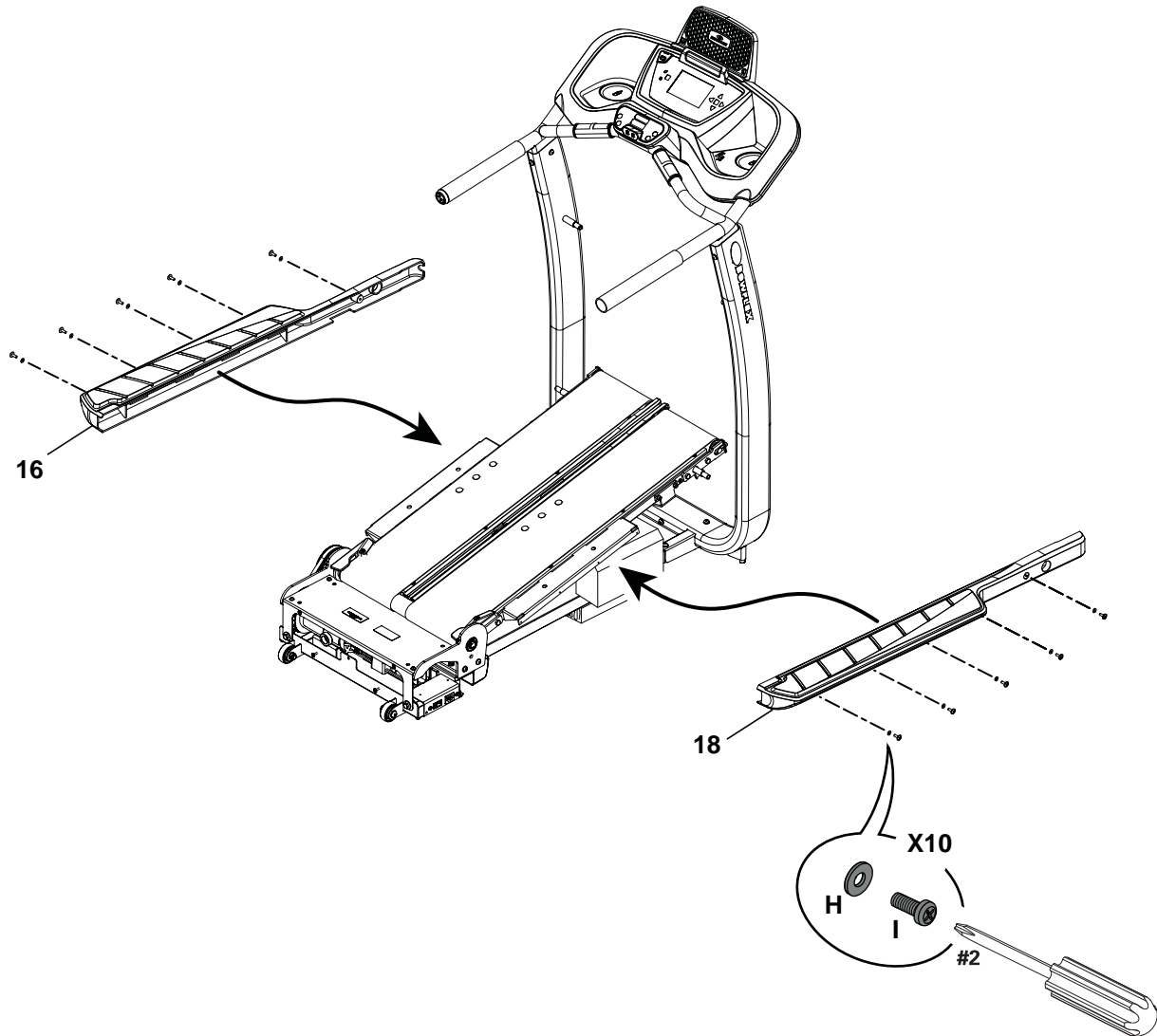

## 9. Attach the Shocks to Uprights and then Treadles

Note: The settings decal on the Shocks must be up, with the arrows facing to the rear of the machine. Attach to Uprights before the Treadles. Fully tighten ALL hardware from previous steps and safely remove Packaging Boxes.

**!** The Treadles do not have a locking mechanism and can move freely. Take care not to allow harm or injury to occur when lifting the Treadles.

Be aware that the Drive Belt and the Walking Belts are connected and when either of these parts move the other does as well. In order to avoid possible serious injury, do not allow anything to be caught or pinched by the Drive Belt when the Walking Belts are moved.

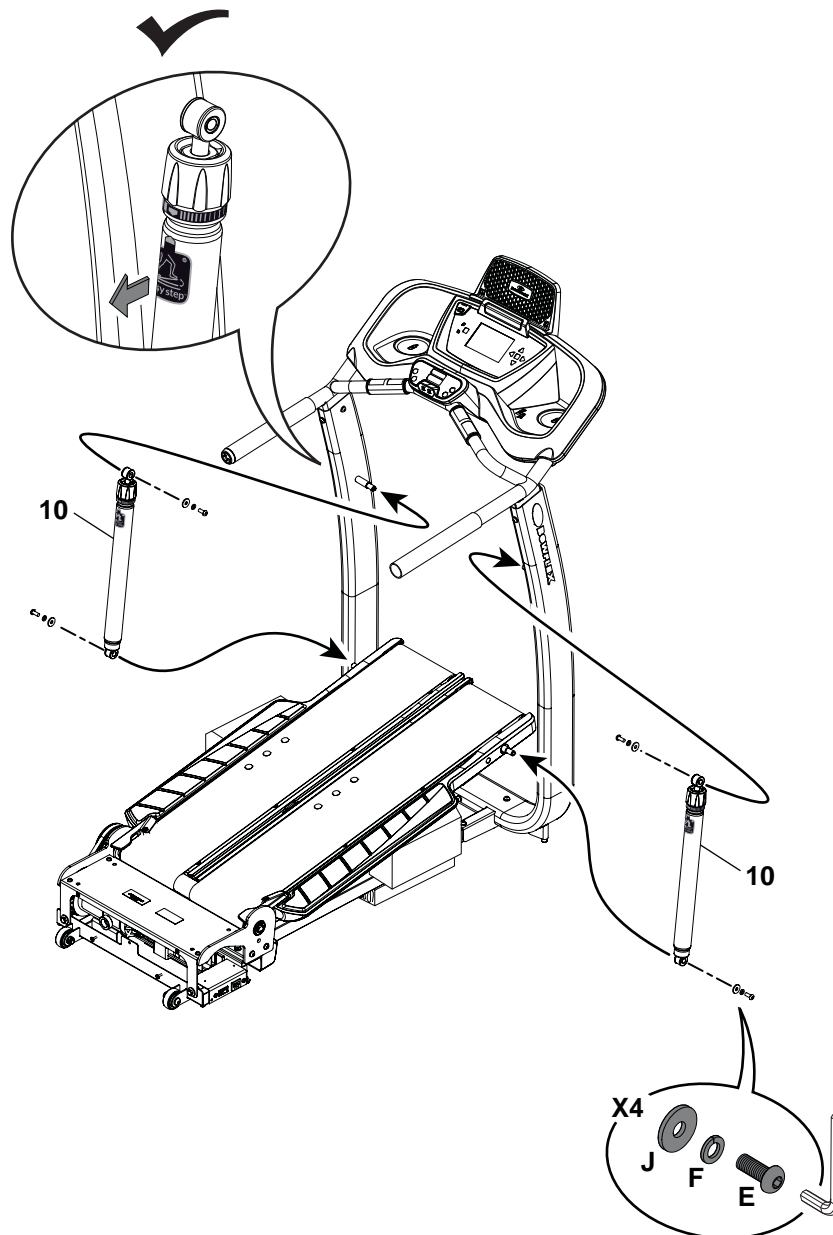

## 10. Attach the Rear Cover onto the Treadle Assembly

Note: Hardware is pre-installed and not on the Hardware Card (\*).

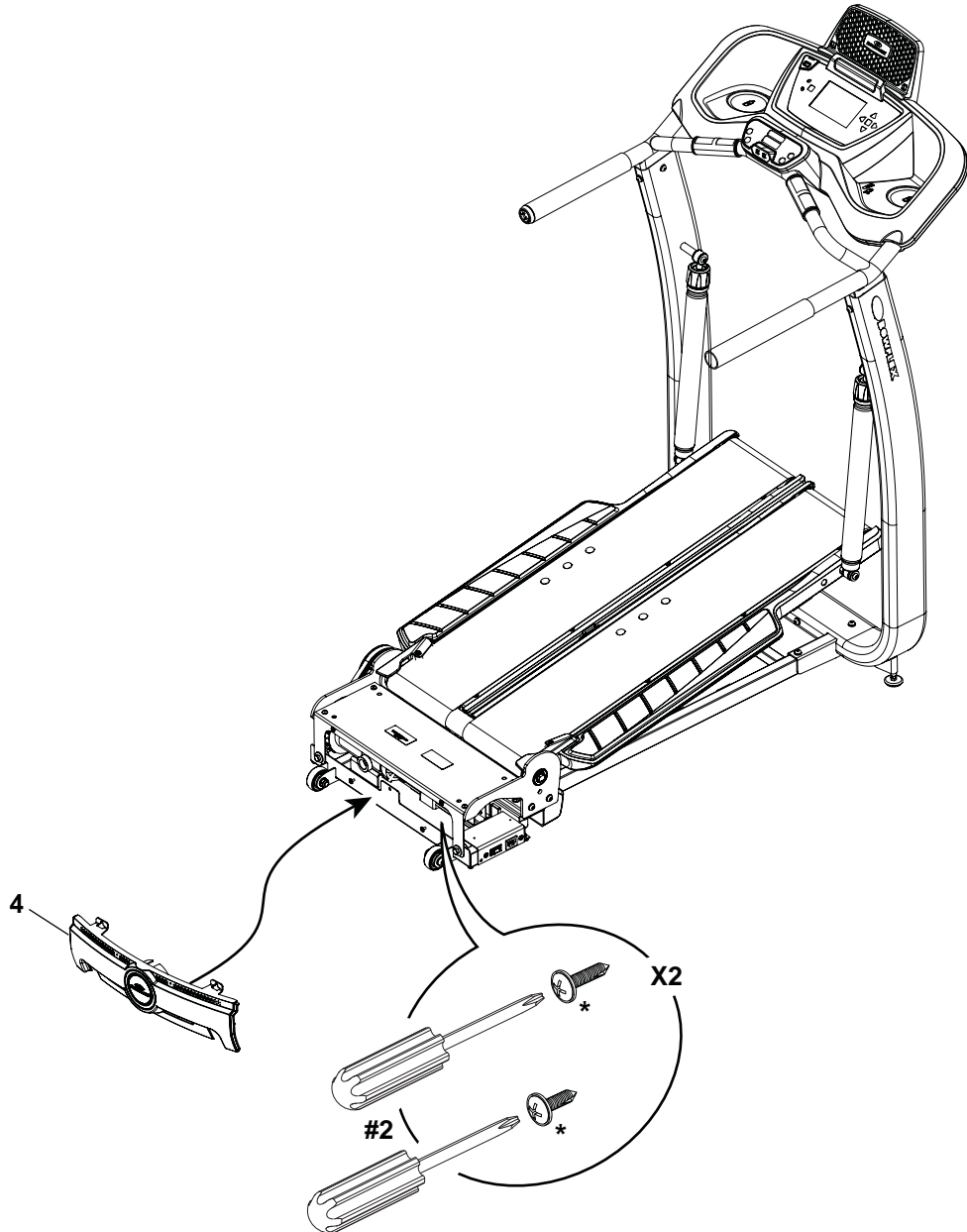

## 11. Safely Tilt the Treadle Assembly and Attach the Side Motor Covers and Levels

**!** The machine may be moved by one or more persons depending on their physical abilities and capacities. Make sure that you and others are all physically fit and able to move the machine safely.

Note: Hardware is pre-installed and not on the Hardware Card.  
Return the machine upright and repeat on opposite side.

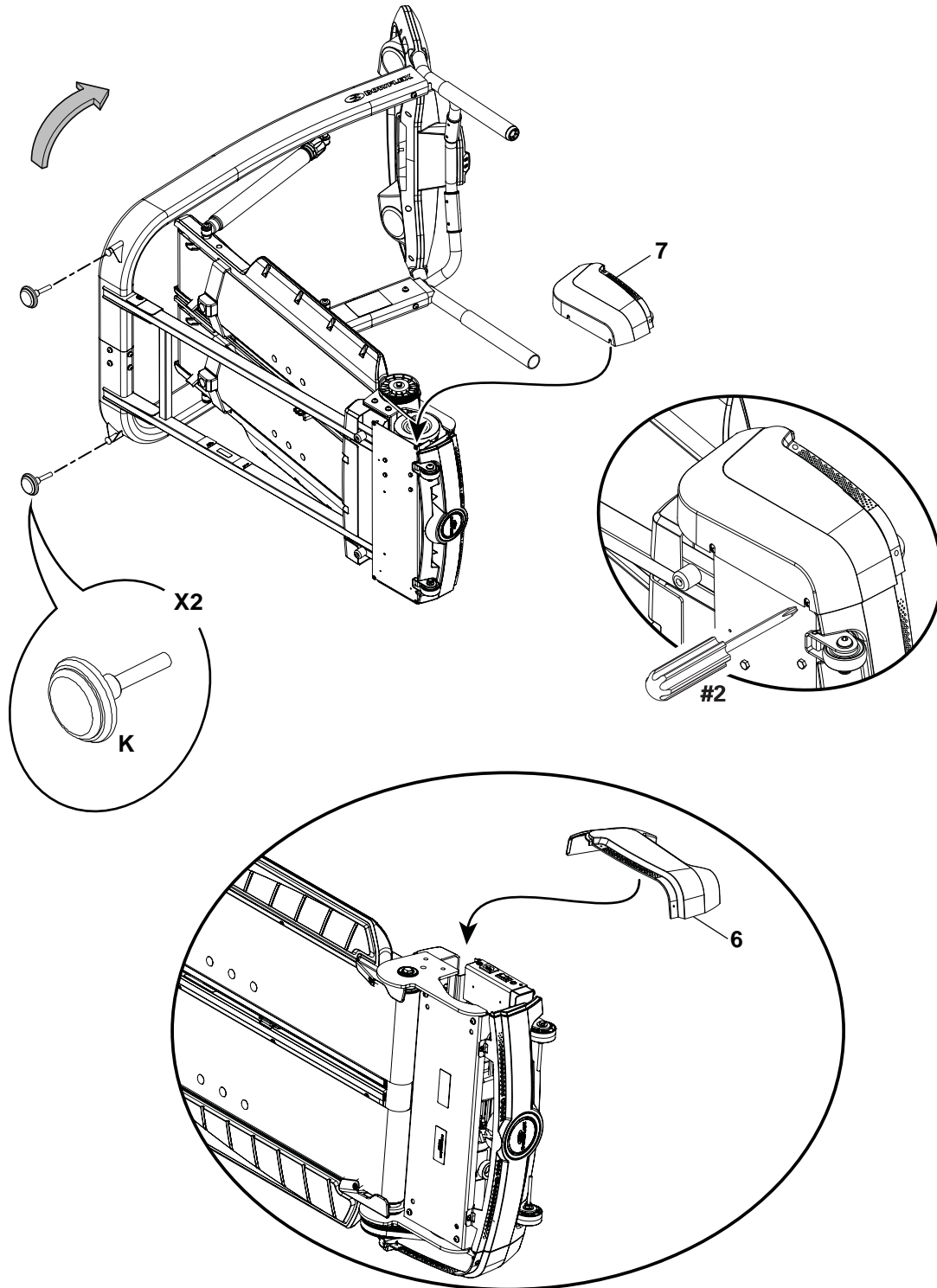

## 12. Attach the Rear Step to the Treadle Assembly

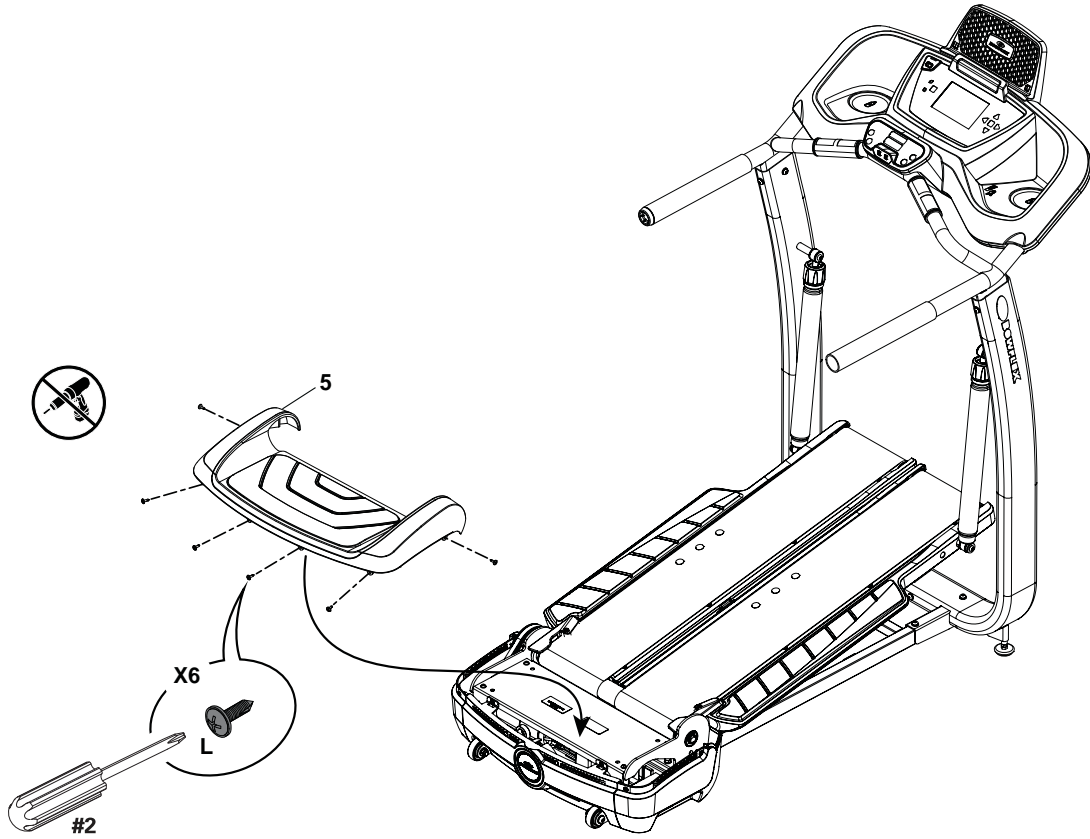



### 13. Connect Power Cord to Treadle Assembly

Note: The TC100 TreadClimber® fitness machine is designed to plug directly into a properly wired and grounded three prong 120V outlet. If you connect the machine to an outlet with GFI (ground fault interrupt) or AFCI (arc fault circuit interrupt), machine operation can cause the circuit to trip.

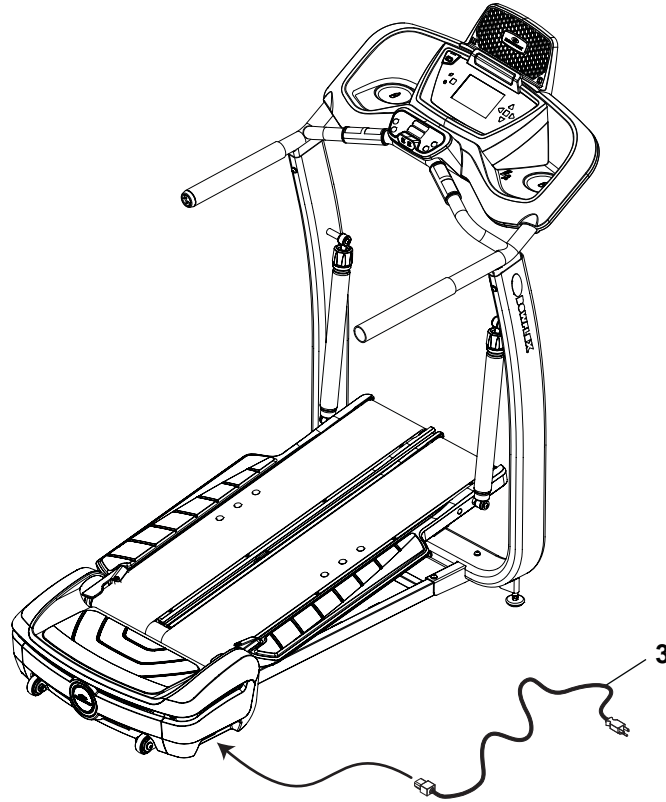

### 14. Final Inspection

Inspect your machine to ensure that all fasteners are tight and components are properly assembled.

**⚠ Do not use until the machine has been fully assembled and inspected for correct performance in accordance with the Owner's Manual.**

# Adjustments

## Moving Your Machine

The TreadClimber® fitness machine weighs approximately 158 lbs (71.8 kg) when fully assembled and requires caution when being moved. Use the Transport Hand Bar found under the front of the machine to move it. To get access to the Transport Hand Bar, turn the Levelers until you have sufficient clearance between the machine and floor.

Your machine can be rolled on the transport wheels to a new location. Lower your machine slowly into its new location without injury to your head or fingers.

**!** Do not use the uprights, handlebars, or the Console to lift or move the machine. Injury to you or damage to the machine can occur.

The machine may be moved by one or more persons depending on their physical abilities and capacities. Make sure that you and others are all physically fit and able to move the machine safely.

Place the machine on a clean, hard, level surface, free from unwanted material or other objects that may hamper your ability to move freely. A rubber mat should be used below the machine to prevent the release of static electricity and protect your flooring.

For safe storage of the machine and to prevent unsupervised operation of the machine always remove the Safety Key and disconnect the power cord from the wall outlet and the AC input. Place the power cord in a secure location

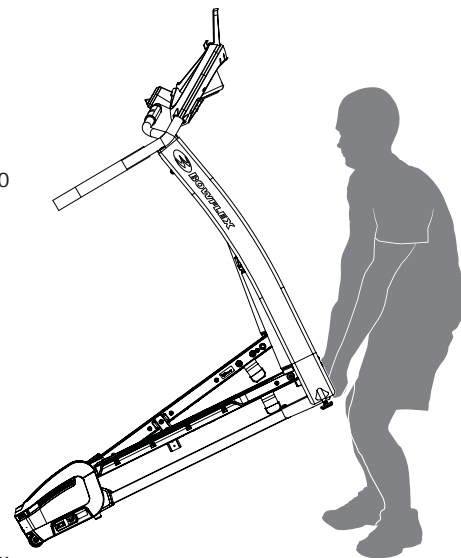

## Leveling Your Machine

Levelers are found on the front of the TreadClimber® machine. Make sure the TreadClimber® machine is level and stable before you exercise. To adjust:

1. Loosen the upper locking nut.
2. Turn the leveler to adjust the height.
3. Tighten the upper locking nut to lock the leveler.

**!** Do not adjust the levelers to such a height that they detach or unscrew from the machine. Injury to you or damage to the machine can occur.

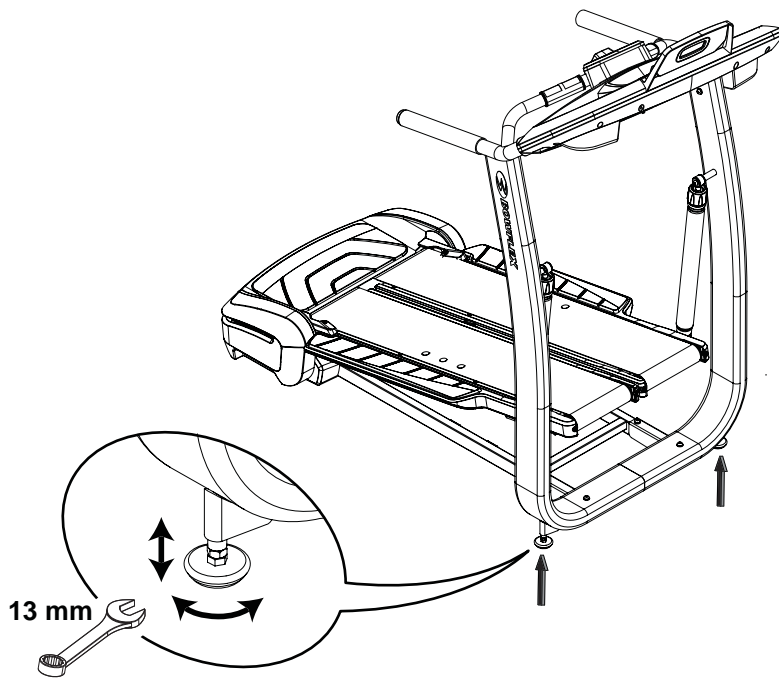

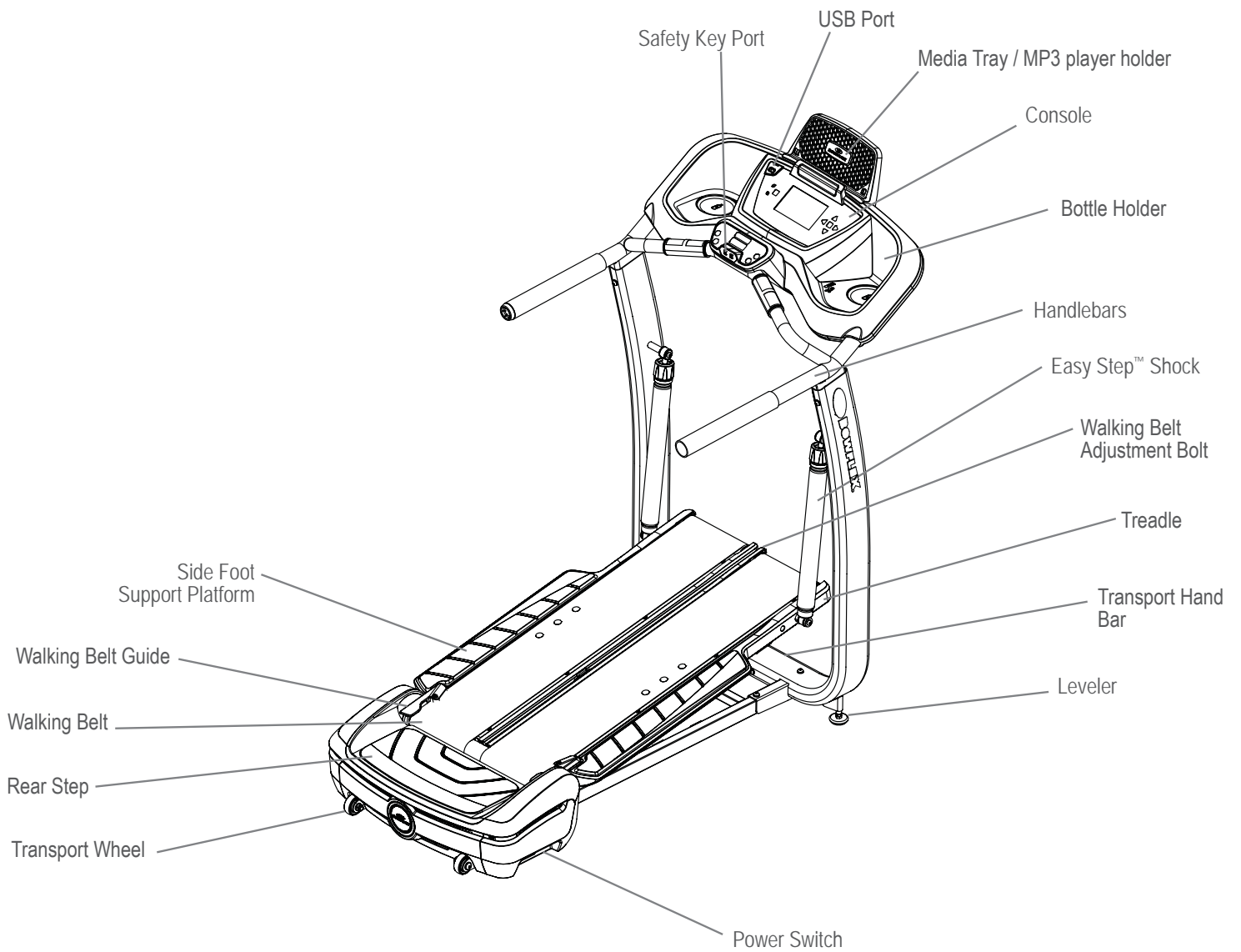

## Console Features

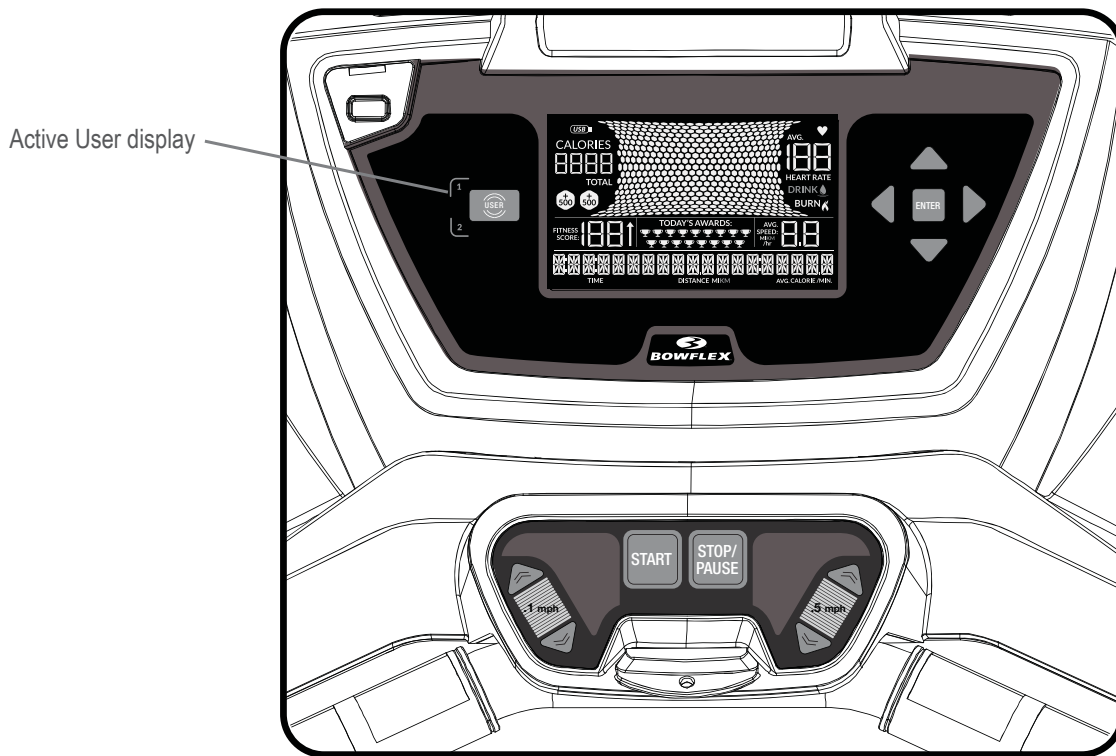

### User button

Push to change the selected Active User.

### Active User display

The Active User display shows the currently selected User Profile. From a power up, the last User will be the default User.

### Increase (▲)/Decrease (▼) buttons

The Increase / Decrease buttons change a value, or move through options. When a button is an option, it will light up to indicate it is available.

### ENTER button

Confirms information or a selection.

### Left (◀)/Right (▶) buttons

Push to shift the currently active segment. When a button is an option, it will light up to indicate it is available.

### START button

Push to start a workout or resume a paused workout.

### STOP/PAUSE button

Push to pause a workout, exit the User Profile or Machine Settings mode, or end a paused workout.

### Speed buttons (Increase and Decrease)

Push to change the speed of the belts by 0.1 mph/kph increments, push and hold to quickly change the belt speed.

### Quick Speed buttons (Increase and Decrease)

Push to change the speed of the belts by 0.5 mph/kph increments, push and hold to quickly change the belt speed.

## Console Display

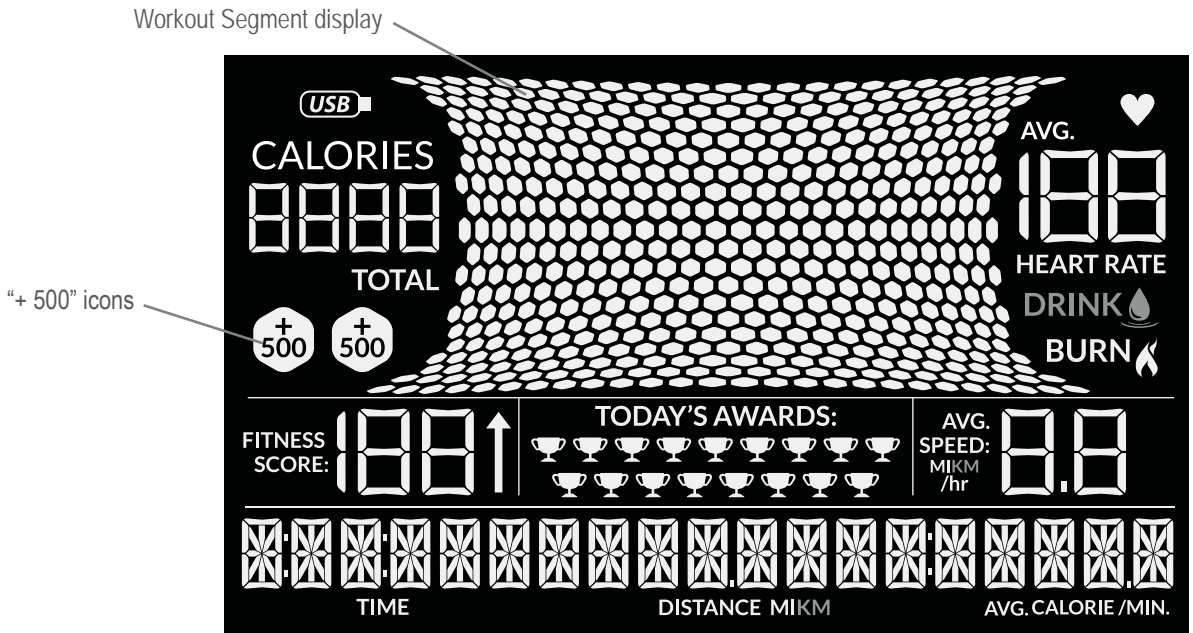

### USB icon

The USB icon is displayed when a USB Flash Drive or Device is attached to the Console. The USB icon will flash when the Console is saving information to the USB Port. Do not remove the USB Flash Drive/Device when the icon is flashing. Damage to the Drive/Device may occur.

### Calories display

The Calories display counts your total calories. The maximum value for calories during a workout is 9999.

### Workout Segment display

The Workout Segment display shows graphically where the user is in the workout. Each segment of the display is 1 calorie.

When 500 calories have been burned, the Console will activate the "+ 500" icon and reset the workout segments by deactivating them. Two calorie roll overs are available for each workout.

### "+ 500" icon

Graphically shows that the Workout Segment display has rolled over during a calorie goal workout. Two calorie roll overs are available for each workout.

### Heart Rate display

The Heart Rate display shows your heart beats per minute. The heart icon will flash when acquiring the rate. With a stable reading, the icon will be shown as solid.

**!** The heart rate displayed is an approximation and should be used for reference only.

### Drink display

The Drink display is a reminder to stay hydrated during an extended workout.

### **Burn display**

The Burn display activates when the heart rate of a user reaches the anaerobic rate, or 80-89%, of their maximum heart rate. The Console will display "AFTERBURN ACHIEVED", and a Trophy icon is awarded.

Note: Once displayed, the Burn display will deactivate when the heart rate is not in the anaerobic rate zone. Since the Console is using the age value for the selected User, be sure to program and select the correct User profile.

### **Fitness Score display**

The display shows the current Fitness Score for the selected User. At the end of a workout, if the Fitness Score has increased, an upward arrow icon will be displayed to show the increase in the score.

Note: This display is blank during the workout mode.

### **Today's Awards display**

Shows all of the earned Award icons during a workout. When earned, the Console will display the name of the achievement. A summary of Awards is also provided at the end of the workout.

Note: Some Awards can only be earned once during a workout, such as "Started a Workout" or "Afterburn Achieved".

### **Speed display**

Shows your climbing rate in miles (MI) or kilometers (KM) per hour to one decimal (e.g. 3.4 MI). MI is the default setting.

### **Time display**

Counts in minutes and seconds the total time of your workout (e.g. 15:42 minutes). The hour field will activate when a workout goes longer than 59:99. The maximum time for a workout is 9:59:99.

### **Distance display**

The Distance display shows your workout distance in miles (MI) or kilometers (KM). Miles is the default setting.

Note: When you workout a distance more than "99.99", the display will activate another segment to display "100.00".

### **Calories per Minute ( or Burn Rate ) display**

The Calories per Minute, or Burn Rate, display shows the rate of calories burned for a minute at the current workout levels.

## **USB Charging**

If a USB Device is attached to the USB Port, the Port will attempt to charge the Device. The power supplied from the USB Port may not be enough to operate the Device and charge it at the same time.

## Easy Step™ Shocks

Your TreadClimber® machine uses Easy Step™ Shocks to absorb your steps and cushion your joints, decreasing your overall fatigue and reducing muscle strain. The displacement of the Treadles is adjusted by the dials on the Easy Step™ Shocks. The Minimum Travel setting is the least amount of Treadle movement, the Maximum Travel is the greatest movement. The closer the dial is set to the Maximum Travel setting, the more the Treadle will move. This results in a more intense workout.

For maximum cushioning, the Treadles should be set so they displace enough to absorb the impact of your stepping motion, approximately 3 inches. Begin with each Shock set with the arrows aligned. If this setting does not move enough to fully cushion your steps, adjust the dial setting toward the Maximum (counter-clockwise) setting, allowing more Treadle movement. If you find that the Shock setting allows too much Treadle travel, adjust the dial toward the Minimum (clockwise) setting until you are comfortable with the amount of travel. Although the settings dial can move continuously in either direction, it is recommended not to turn the dials through the red range.

 Do not change the intensity settings of the Shocks during a workout. Stop the workout and step off the machine before you adjust the Shocks.

Note: Do not allow the Treadles to hit against the Base on the down step. To reduce Treadle travel, turn the setting dial toward the Minimum setting or increase the belt speed.

It may be helpful to note your dial setting for future reference when there are multiple users of the machine.

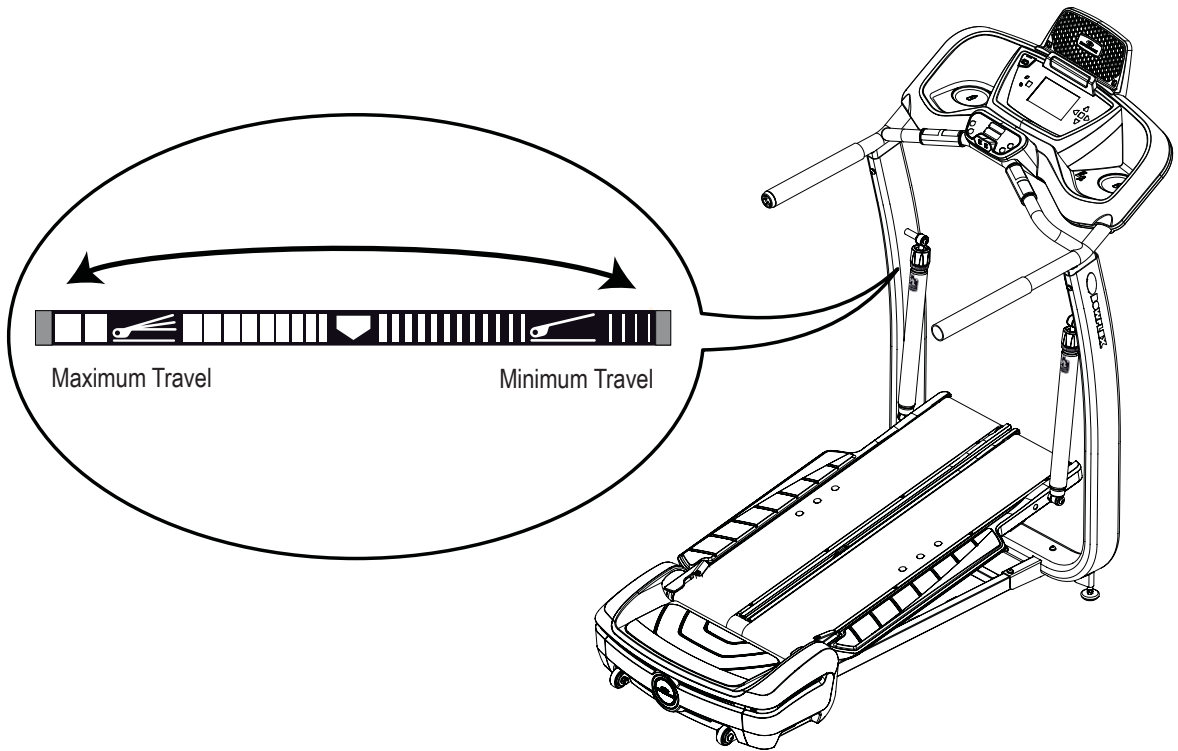
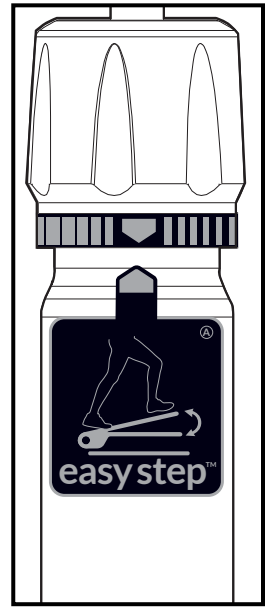



## Contact Heart Rate Sensors

Contact Heart Rate (CHR) sensors send your heart rate signals to the Console. The CHR sensors are the stainless steel parts of the Handlebars. To use, put your hands comfortably around the sensors. Be sure that your hands touch both the top and the bottom of the sensors. Hold firm, but not too tight or loose. Both hands must make contact with the sensors for the Console to detect a pulse. After the Console detects four stable pulse signals, your initial pulse rate will be shown.

Once the Console has your initial heart rate, do not move or shift your hands for 10 to 15 seconds. The Console will now validate the heart rate. Many factors influence the ability of the sensors to detect your heart rate signal:

- Movement of the upper body muscles (including arms) produces an electrical signal (muscle artifact) that can interfere with pulse detection. Slight hand movement while in contact with the sensors can also produce interference.
- Calluses and hand lotion may act as an insulating layer to reduce the signal strength.
- Some Electrocardiogram (EKG) signals generated by individuals are not strong enough to be detected by the sensors.
- The proximity of other electronic machines can generate interference.

If your heart rate signal ever seems erratic after validation, wipe off your hands and the sensors and try again.



**The heart rate displayed is an approximation and should be used for reference only.**

# Heart Rate Calculations

Your maximum heart rate usually decreases from 220 Beats Per Minute (BPM) in childhood to approximately 160 BPM by age 60. This fall in heart rate is usually linear, decreasing by approximately one BPM for each year. There is no indication that training influences the decrease in maximum heart rate. Individuals of the same age could have different maximum heart rates. It is more accurate to find this value by getting a stress test than by using an age related formula.

Your at rest heart rate is influenced by endurance training. The typical adult has an at rest heart rate of approximately 72 BPM, where as highly trained runners may have readings of 40 BPM or lower.

The Heart Rate table is an estimate of what Heart Rate Zone (HRZ) is effective to burn fat and improve your cardiovascular system. Physical conditions vary, therefore your individual HRZ could be several beats higher or lower than what is shown.

The most efficient procedure to burn fat during exercise is to start at a slow pace and gradually increase your intensity until your heart rate reaches between 60 – 85% of your maximum heart rate. Continue at that pace, keeping your heart rate in that target zone for over 20 minutes. The longer you maintain your target heart rate, the more fat your body will burn.

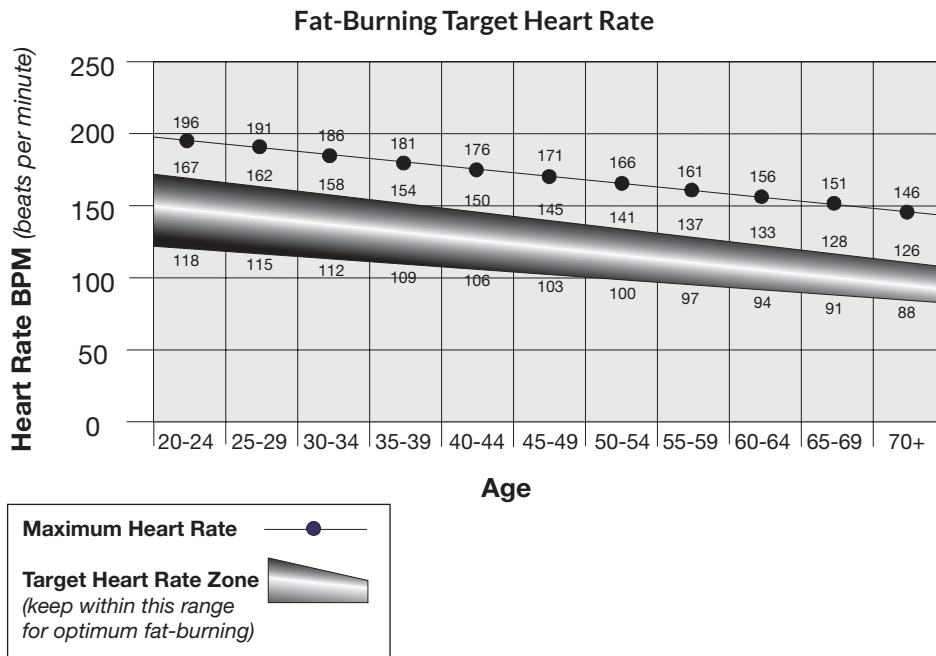

The graph is a brief guideline, describing the generally suggested target heart rates based on age. As noted above, your optimal target rate may be higher or lower. Consult your physician for your individual target heart rate zone.

Note: As with all exercises and fitness regimens, always use your best judgment when you increase your exercise time or intensity.

## Fitness Basics

### Frequency

To maintain good health, lose weight and improve your cardiovascular endurance, try and use the TreadClimber® fitness machine a minimum of 3 times per week, 30 minutes each day.

If you are new to exercise (or returning to a regular exercise program), and you are unable to comfortably complete 30 minutes of continuous exercise at one time, just do 5 – 10 minutes, and gradually increase your workout time until you can reach 30 minutes total.

If your schedule is busy, and you are unable to fit 30 minutes of continuous exercise into your day, try accumulating 30 minutes by doing multiple shorter workouts on the same day. For example, 15 minutes in the morning and 15 minutes in the evening.

For best results, combine your TreadClimber® fitness machine workouts with a strength training program using a Bowflex® home gym or Bowflex® SelectTech® dumbbells, and follow the Bowflex™ Body Weight Loss Guide that is included in this manual.

### Consistency

Busy work schedules, family obligations and daily chores can make it difficult to fit regular exercise into your life. Try these tips to increase your chances of success:

Schedule your workouts the same way you schedule meetings or appointments. Select specific days and times each week, and don't change your workout times unless it is absolutely necessary.

Make a commitment to a family member, friend or spouse, and encourage each other to stay on track each week. Leave messages with friendly reminders to be consistent, and keep each other accountable.

Make your workouts more interesting by alternating between steady state (single-speed) workouts and interval training (varied speed) workouts. The TreadClimber® fitness machine is even more fun when you add this kind of variety.

### Apparel

It is important to wear appropriate, safe and comfortable footwear and clothing when using the TreadClimber® fitness machine, including:

- Rubber-soled athletic walking or running shoes.
- Exercise clothing that allows you to move freely, and keep comfortably cool.
- Athletic support that provides stability and comfort.

 **Do not wear loose clothing or jewelry. This machine contains moving parts. Do not put fingers, feet, or other objects into moving parts of the exercise equipment.**

Always wear rubber soled athletic shoes when you use this machine. Do not use the machine with bare feet or only wearing socks.

**Because of how the Treadles and Walking Belts operate, it is possible for extremely light-weight, flexible shoes, or minimalist shoes, to be caught. Only wear athletic shoes that have more toe protection, structure, and support. Light-weight or minimalist shoes should not be worn.**

### Warm-Up\*

Before you use your TreadClimber® fitness machine, consider doing these dynamic warm-up stretches, which will help prepare your body for the workout:

\* Source: Jay Blahnik's Full-Body Flexibility, Second Edition, 2010. HumanKinetics.com.

---

### Dynamic Knee Hug

Stand with the feet together. Bring one knee forward and up toward the chest. Place the hands around the shin and pull the knee into the chest. Release the stretch by putting the foot on the floor. Each repetition of the sequence should take 1 to 3 seconds. Repeat as a continuous, controlled, fluid sequence 10 or 20 times. Repeat the stretch with the other leg.

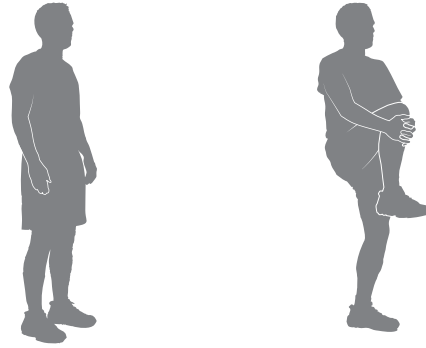

---

### Dynamic Knee Bend

Stand with the feet together. Raise the heel of one foot toward the gluteals. Release the stretch by putting the foot on the floor. Each repetition of the sequence should take 1 to 3 seconds. Repeat as a continuous, controlled, fluid sequence 10 or 20 times. Repeat the stretch with the other leg.

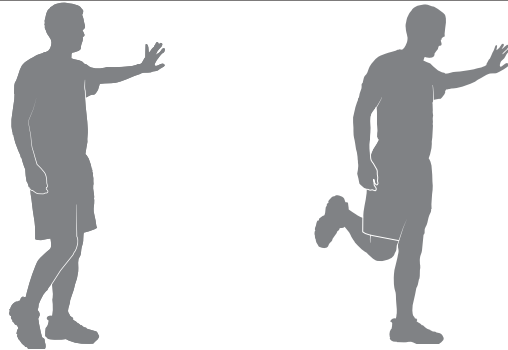

---

### Dynamic Knee Kick

Stand tall and hold one leg up with the hands at hip height, keeping the knee bent. Hold onto a wall for balance with one hand, if necessary. Straighten the knee as far as comfortably possible. Release the stretch by bending the knee. Each repetition of the sequence should take 1 to 3 seconds. Repeat as a continuous, controlled, fluid sequence 10 or 20 times. Repeat the stretch with the other leg.

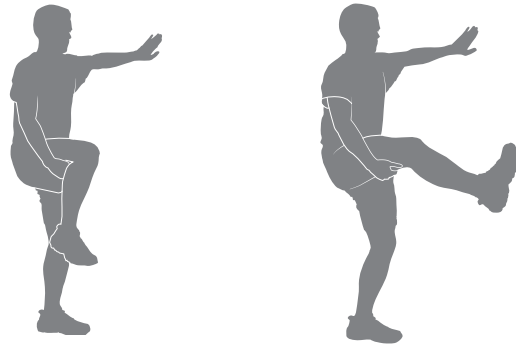

---

### Dynamic Twist

Stand with the feet shoulder-width apart. Bend the elbows; hold the arms out to the sides. Twist the upper body to one side and then the other side as far as comfortably possible. Each repetition of the sequence should take 1 to 3 seconds. Repeat as a continuous, controlled, fluid sequence 10 or 20 times.

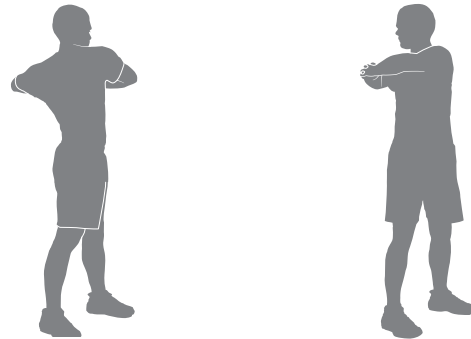

---

### Dynamic Bent Knee Heel Press

Stand with one foot forward and one foot back, hip-width apart and feet facing forward. Bend both knees putting weight on the back heel. Release the stretch by returning to the start position. Each repetition of the sequence should take 1 to 3 seconds. Repeat as a continuous, controlled, fluid sequence 10 or 20 times. Repeat the stretch with the other leg. Touch a wall or hold onto something for balance, if necessary.

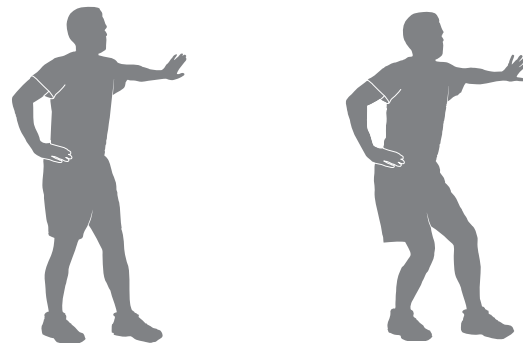

---

### Dynamic Side Reach

Stand with the feet apart, the knees slightly bent and the arms at the sides of the body. Reach with one hand above the head and lean over to the opposite side. Release the stretch by returning to the start position. Then reach with the other hand to the opposite side. Use the other arm to support the body weight on the thigh, if necessary. Each repetition of the sequence should take 1 to 3 seconds. Repeat as a continuous, controlled, fluid sequence 10 or 20 times.

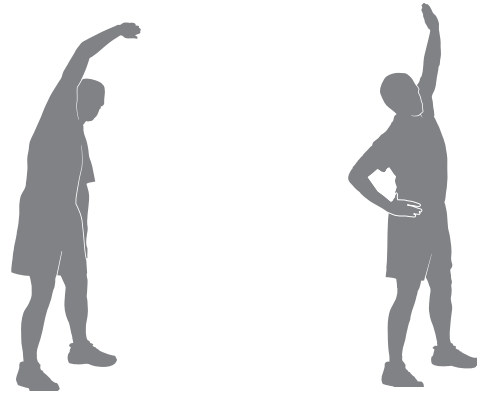

---

## Workouts

Follow these guidelines to ease yourself into a weekly exercise regimen. Use your judgment and/or the advice of your physician or health care professional to find the intensity and level of your workouts.

**⚠ Consult a physician before you start an exercise program. Stop exercising if you feel pain or tightness in your chest, become short of breath, or feel faint. Contact your doctor before you use the machine again. Use the values calculated or measured by the machine's computer for reference purposes only.**

Steady State and Interval Training are 2 types of workouts you can do on your TreadClimber® fitness machine:

### Steady State workouts

A Steady State workout involves slowly increasing your workout speed to a challenging, but comfortable speed you can hold for most of your workout. For example, holding a 3.0 MPH walking pace for the entire workout, except during the warm-up and cool-down. Steady State workouts help you build exercise confidence, stamina and endurance, and are essential to a well-rounded cardiovascular training program.

### Interval Training workouts

An Interval Training workout involves adjusting your speed faster and slower for specific lengths of time to raise and lower your breathing rate, heart rate and calorie burn. Here is a sample Interval Training workout:

- 7 minutes walking at a slow, easy, comfortable speed.
- 1 minute walking at a more challenging speed that is approximately 50% faster.
- 7 minutes walking at a slow, easy, comfortable speed.
- 1 minute walking at a more challenging speed that is approximately 2x faster.
- 7 minutes walking at a slow, easy, comfortable speed.
- 1 minute walking at a more challenging speed that is approximately 50% faster.
- 6 minutes walking at a slow, easy, comfortable speed.

Interval Training workouts provide variety, maximize calorie burn and improve fitness.

The TreadClimber® fitness machine is designed to cushion your joints and muscles, and both Steady State and Interval Training workouts should feel more comfortable than walking or running outside on a hard surface or a treadmill.

### Afterburn Rate

At the end of an intense Interval Training workout, your body will actually need to expend additional energy to replenish your body's reserves. This additional amount of energy that your body will be using is the Afterburn Rate, or EPOC (Excess Post-exercise Oxygen Consumption). The level of this additional energy requirement for your body is directly related to many factors. Some factors are your physical fitness level, intensity level of the interval training workout, length of oxygen deprivation during the workout, and physical demands during the recovery phase.

In summary, your body will be burning more calories for hours after your workout. So after an intense Interval workout, you may feel the effects for hours afterwards.

## Workout Schedule

Here is a beginner, intermediate and advanced sample workout schedule. Use the workout schedule that reflects your current fitness level. With each of these sample workout schedules, do not move on to the next week until the current week feels easier and comfortable.

<b>Beginner</b>	<b>Week 1</b>	<b>Week 2</b>	<b>Week 3</b>	<b>Week 4</b>	<b>Week 5</b>
<b>Workout 1</b>	Steady State	Steady State	Steady State	Interval Training	Interval Training
<b>Workout 2</b>	Steady State	Steady State	Interval Training	Steady State	Steady State
<b>Workout 3</b>	Steady State	Steady State	Steady State	Interval Training	Interval Training

<b>Intermediate</b>	<b>Week 1</b>	<b>Week 2</b>	<b>Week 3</b>	<b>Week 4</b>	<b>Week 5</b>
<b>Workout 1</b>	Steady State	Steady State	Interval Training	Steady State	Interval Training
<b>Workout 2</b>	Steady State	Interval Training	Steady State	Interval Training	Steady State
<b>Workout 3</b>	Steady State	Steady State	Interval Training	Steady State	Interval Training

<b>Advanced</b>	<b>Week 1</b>	<b>Week 2</b>	<b>Week 3</b>	<b>Week 4</b>	<b>Week 5</b>
<b>Workout 1</b>	Steady State	Interval Training	Interval Training	Interval Training	Interval Training
<b>Workout 2</b>	Interval Training	Steady State	Steady State	Steady State	Interval Training
<b>Workout 3</b>	Steady State	Interval Training	Interval Training	Interval Training	Interval Training



## Cool-Down \*

When you are done using your TreadClimber® fitness machine, consider doing these relaxing stretches, which will help your body recover from the workout and make you more flexible:

---

### Lying Leg Raise

Lie on the floor face up with the legs slightly bent. Lift one leg up toward the ceiling, keeping the knee straight. Place the hands (or a strap) around the thigh and move the leg closer to the head. Hold the stretch for 10 to 30 seconds. Repeat the stretch on the other leg. Keep the head on the floor and do not round the spine.

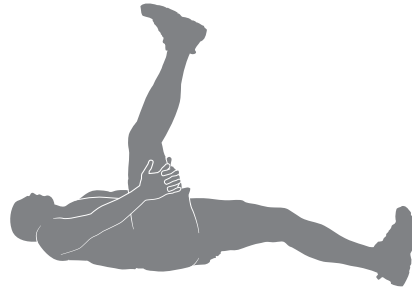

### Side Lying Knee Bend

Lie on the floor on one side of the body and rest the head on the lower arm. Bend the top knee and hold the ankle with the same-side hand, then pull the heel toward the gluteals. Hold the stretch for 10 to 30 seconds. Lie on the other side and repeat the stretch with the other leg. Remember to hold the knees close together.

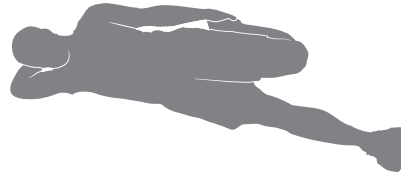

### Lying Figure Four

Lie on the floor face up with the legs bent. Place one foot across the thigh of the opposite leg in the figure four position. Reach for the leg on the floor and pull it toward the chest. Hold the stretch for 10 to 30 seconds. Repeat the stretch with the other leg. Keep the head on the floor.

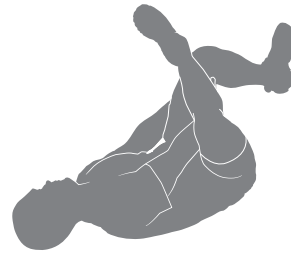

### Seated Twist

Sit on the floor and extend the legs straight out in front of the body with the knees slightly bent. Place one hand on the floor behind the body and the other hand across the thigh. Twist the upper body as far as comfortably possible to one side. Hold the stretch for 10 to 30 seconds. Repeat the stretch on the other side.

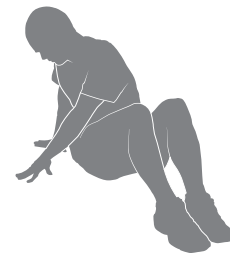

### Seated Figure Four

Sit on the floor and extend one leg straight out in front of the body. Place the foot of the other leg across the thigh in the figure four position. Move the chest toward the legs, pivoting at the hip. Hold the stretch for 10 to 30 seconds. Repeat on the other leg. Use the arms to support the back.



---

\* Source: Jay Blahnik's Full-Body Flexibility, Second Edition, 2010. HumanKinetics.com.



---

### Dynamic Heel Drop

Place the ball of one foot on the edge of a step or staircase. Place the other foot slightly in front. Lower the heel of the back foot as far as comfortably possible, keeping the knee straight. Release the stretch by lifting the heel as high as comfortably possible. Each repetition of the sequence should take 1 to 3 seconds. Repeat as a continuous, controlled, fluid sequence 10 or 20 times. Repeat the stretch with the other leg

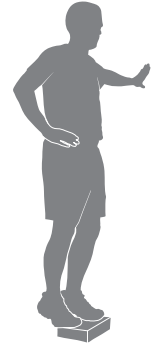

## Before You Start

**⚠** Consult a physician before you start an exercise program. Stop exercising if you feel pain or tightness in your chest, become short of breath, or feel faint. Contact your doctor before you use the machine again. Use the values calculated or measured by the machine's computer for reference purposes only.

1. Place the TreadClimber® fitness machine in your workout area.

**⚠** Place the machine on a clean, hard, level surface, free from unwanted material or other objects that may hamper your ability to move freely. A rubber mat can be used below the machine to prevent the release of static electricity and protect your flooring.

The machine can be moved by one or more persons. Make sure that your own physical strength is capable of safely moving the machine.

2. Adjust the intensity settings on the Easy Step™ Shocks.

Note: Initially, the settings on each Shock should match. Begin with each Shock set with the arrows aligned.

3. Connect the power cord to the machine and into a grounded AC Wall Outlet.

Note: The TreadClimber® fitness machine is designed to plug directly into a properly wired and grounded three prong 120V outlet. If an extension cord must be used, be sure it is a heavy duty model, rated for 15A.

**⚠** Put the power cord alongside the machine, out of your way when you dismount the machine. Avoid stepping on the power cord and plug.

4. Examine below the Treadles for any objects. Be sure it is clear below the machine.

5. Switch on the power. Power is now supplied to the machine.

6. Straddle the belts and stand on the Side Foot Support Platforms. Put the Safety Key into the Safety Keyhole and clip the Safety Key cord to your clothing.

- The Safety Key must be correctly put into the Safety Keyhole for the Belt Motor to engage.
- Always attach the Safety Key Clip to your clothing during workouts.
- If there is an emergency, pull out the Safety Key to shut off the power to the Belt Motor. This will quickly stop the belts (brace yourself- this is an abrupt stop).

7. Push the START button, and begin your workout when the belts are up to speed.

**⚠** The belts will only move after a 3 second, audible beep countdown.

If the Sound has been muted, the Console will display the "AUDIO OFF" prompt before a Workout starts as a reminder.

Keep your hands on the support Handlebars and stay as near the front of the machine as is comfortable in order to stay in balance on the Treadles.

Keep your foot in the center of each Treadle, do not let your feet cross in front of your body as you increase the speed.

When you are experienced and comfortable with the action of the machine, you may wish to allow your arms to swing freely in a natural walking motion. This workout will activate your core muscles. It should only be done by those comfortable with not holding on to the Handlebars.

## Power Up / Idle Mode

The Console will enter Power Up mode when initially plugged into a power source and the On/Off button is switched to On.

**⚠** The belts will only move after a 3 second, audible beep countdown.

## Shut Off (Sleep Mode)

If the Console does not receive any input for five minutes, it will automatically shut off.

Push any button to start (wake up) the Console.

## Initial Setup

During the first power-up, the Console will request the date and time for workout tracking.

1. The Console display shows the SET DATE prompt with the default date setting. The month value will be the currently active value (flashing). Push the Increase (▲) or Decrease (▼) buttons to adjust the currently active value (flashing). Push the Left (◀) or Right (▶) buttons to change which segment is the currently active value (month / day / year).
2. Push the Right button until the next prompt is displayed.
3. The Console display shows the SET TIME prompt with the default time setting. The hour value will be the currently active value (flashing). Push the Increase/Decrease buttons to adjust the currently active value (flashing). Push the Left/Right buttons to change which segment is the currently active value (hour / minute / AM or PM).
4. Push ENTER to set.

The Console goes to the Power-Up Mode screen.

Note: To adjust these settings after the Initial Setup, consult the “Console Set-Up Mode” section.

## User Profiles

The Console is equipped with 2 User Profiles. Each User Profile has values and options specific to it:

- Gender
- Year of Birth
- Display Units
- Weight
- Sound Volume
- Erase Workouts

### Select a User Profile

Every workout is saved to the User Profile and can be reviewed with the online health tracker at [www.bowflexconnect.com](http://www.bowflexconnect.com). Be sure to select the proper User Profile before starting a workout. The last User that completed a workout will be the default User.

User Profiles are assigned the default values until they are customized by editing. Be sure to edit the User Profile for more accurate calorie and heart rate information.

### Edit User Profile

1. From the Power-Up Mode screen, push the User button to select one of the User Profiles.
2. Push and hold down the User button to edit the User Profile.
3. The Console display shows the Gender prompt and the current value. Push the Increase or Decrease buttons to change the displayed Gender value, and push the ENTER button to accept the displayed value.

Note: To exit the User Profile options, push the STOP/PAUSE button and the console will go back to the Power-Up Mode screen.

- To edit the other User data (Year of Birth, Display Units, Weight, and Sound Volume) use the Increase (▲) or Decrease (▼) buttons to adjust, and push ENTER to set each option.

Note: To return to the previous prompt push the Left, or Back, arrow button.

 **If the Sound has been muted, the Console will display the “AUDIO OFF” prompt before a Workout starts as a reminder.**

- The Console display shows the Erase Workouts prompt and the current value (“NO”). To erase all workouts for the selected User, push the Increase (▲) or Decrease (▼) button to change the value to “YES”, and push ENTER. The Console will now confirm if the User wants to erase the workouts. Use the Increase (▲) or Decrease (▼) button to change the value to “YES”, and push ENTER. The workouts for this User have been erased.
- The Console display shows the confirmation screen for two seconds, and then will go to the Power-Up Mode screen

## Workout Program

The TreadClimber® cardio machine Workout Program is an open-ended workout allowing for daily adjustments to your workout goal. The workout begins with the Workout Segment Display blank and activates segments as calories are burned. Each segment of the Workout Segment Display represents one calorie. As each calorie is burned, a segment is activated.

Note: When a workout exceeds 500 calories, the Console will activate a “+ 500” icon and deactivate the 500 segments of the Workout Segment Display.

To begin a TreadClimber® workout:

- Review the currently selected User Profile. Push the USER button to change the active User Profile.
- Straddle the belts and stand on the Side Foot Support Platforms. Put the Safety Key into the Safety Keyhole and clip the Safety Key cord to your clothing.
- Push the START button. Your TreadClimber® Workout will begin after the three second, audible beep countdown.

Note: Be sure to read the “Before You Start” section of your manual.

## Changing the Walking Belt Speed

During a workout, the Walking Belt starts at 1.0 mph/kph. To adjust the speed of the Walking Belt, push the Speed Increase or Decrease button to adjust by 0.1 mph/kph increments. Push and hold down the Speed Increase or Decrease button to adjust the increments quickly.

Use the Quick Speed buttons to rapidly adjust the speed of the Walking Belt. The Quick Speed buttons adjust the Walking Belt by 0.5 mph/kph increments.

## Fitness Score Display

The Fitness Score is based on an estimate of the User's VO2 Max and calorie burn over their last five workouts. VO2 Max estimates are calculated using performance data (time, distance and average heart rate or an estimate of average heart rate if that data is unavailable). VO2 Max is the maximal oxygen consumption of the aerobic physical fitness of the individual, and is a determinant of the endurance capacity of the User during prolonged exercise. ( V = Volume, O2 = Oxygen, and Max = maximum rate ).

For every workout completed that is longer than 10 minutes or a mile (1.6 km) in distance, the Console will apply those workout values toward your Fitness Score. This value is displayed on the Fitness Score Display area of the Console.

Note: Using a Heart Rate Chest Strap provides the most accurate information to calculate the Fitness Score. A Fitness Score is provided when a minimum of 10 minutes or 1 mile (1.6 km) of distance is done during a workout. If no heart rate is supplied, an approximation based on the User Profile will be used to calculate the score.

The Fitness Score may change only slightly for a User that performs the same length of workout at a similar intensity level. However, if that same User were to increase intensity over the same length of a workout, their score would increase. Since the score is based on VO2 Max (estimated), even a small score increase shows a significant shift in the User's fitness level.

Note: A User's score may drop slightly if fatigue is present. With the proper combination of exercise and rest, a User's Fitness Score will rise in a similar way to their VO2 Max. This will also be reflected in their ability to perform longer or faster workouts. Fitness Scores should only be compared to your previous scores and not to other User Profiles.

### User Fitness Level Based on Fitness Score

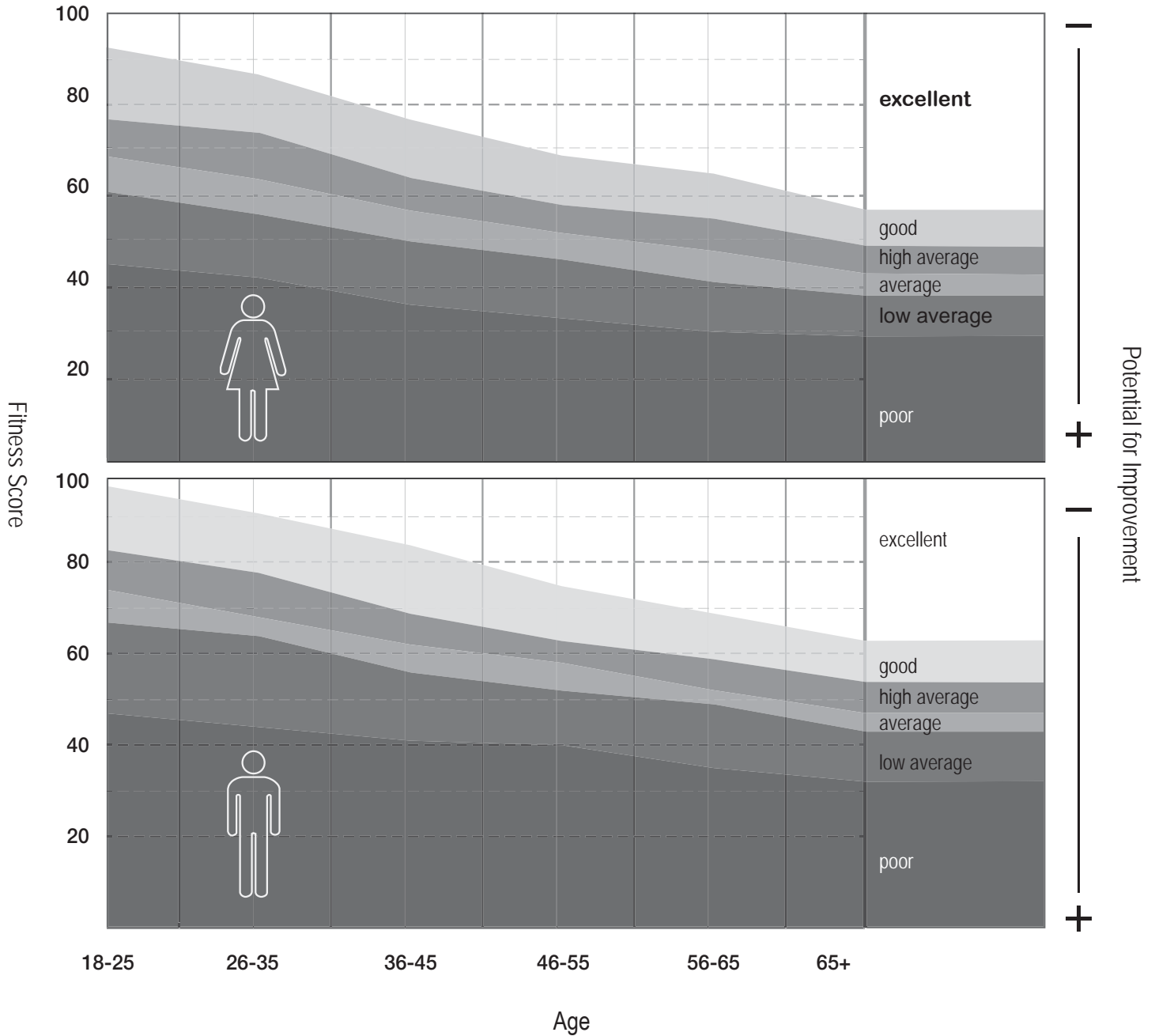

## Pausing or Stopping a Workout

1. With a firm hold on the Handlebars, step off of the belts and onto the Side Foot Support Platforms on either side of the Treadles.
2. Push STOP/PAUSE to pause the workout. The belts will slow to a complete stop.

**Note:** If a paused workout is not restarted in 5 minutes, the machine will end the workout and display the workout results.

3. To restart your workout, push the START button. To end your workout, push STOP/PAUSE again. The Console will display your workout results.

**⚠ To prevent unsupervised operation of the machine always remove the Safety Key and disconnect the power cord from the wall outlet and machine AC input. Place the power cord in a secure location.**

A workout can also be stopped by changing the User during a workout. To select a different User Profile, push the User button. The Console will confirm the change to the User before ending the current workout. Once confirmed, the workout is ended.

## Awards

Awards are given to the User during a workout. When each Award is earned the Console will make an audible sound, display the name of the achievement, and activate an Award icon. The range of Awards varies and can span multiple workouts.



- Started Workout
- For every 100 calories burned
- Afterburn achieved (reached Anaerobic heart zone)
- Fastest 1 mile / 1 kilometer
- Fastest 3 miles / 5 kilometers
- Highest Calories per minute (Cal/Min) rate
- Longest (timed) Workout
- Completed Workout
- Worked out 3 days in a row
- Worked out 5 days in a row
- Worked out for 90 minutes in a week (available once every 7 days, the first day being the first workout)

To review achieved Awards at a later time, export and upload the workout to your account at [bowflexconnect.com](http://bowflexconnect.com). The list of achieved Awards will be provided with the workout results..

## Workout Complete / Results

When the goal of a workout is achieved the Console will display, "Workout Complete," for two seconds and then bring the Walking Belts to a stop. The Console will then display the workout results.

**Note:** If a workout is completed with a USB Flash Drive already inserted, the Console will not export the new Workout Results until the Console exits the Results mode and displays the Power-Up Mode screen. If the Console does not receive any further input after 5 minutes, the Console will shut off.

# Machine Settings Mode

The Machine Settings Mode lets you adjust the date and time, review error messages, update key systems, and view the total run hours for the machine.

1. Hold down the STOP/PAUSE button and Right button together for 3 seconds while in the Power-Up Mode to access the Machine Settings Mode.

Note: Push STOP/PAUSE to exit the Machine Settings Mode and return to the Power-Up Mode screen.

2. The Console display shows the SET DATE prompt with the current date setting. The month value will be the currently active vales (flashing). Push the Increase/Decrease buttons to adjust the currently active value (flashing). Push the Left/Right buttons to change which segment is the currently active value (month / day / year ).
3. Push the Right button until the next prompt is displayed.
4. The Console display shows the SET TIME prompt with the current time setting. The hour value will be the currently active vales (flashing). Push the Increase/Decrease buttons to adjust the currently active value (flashing). Push the Left/Right buttons to change which segment is the currently active value (hour / minute / AM or PM).
5. Push the Right button until the next prompt is displayed.
6. The Console display shows the current Software Version.
7. Push the Right button to go to the next option.
8. The Console display shows the current MCB Version.
9. Push the Right button to go to the next option.
10. The Console display shows the VIEW ERROR MESSAGES prompt. Push the ENTER button to select this option. The Console display shows ERROR VERSION X. Push the Right arrow button to view the error codes.
11. Push STOP/PAUSE to exit the error log.
12. The Console displays the RUN HOURS for the machine.
13. Push the Right button.
14. The Console displays the CONSOLE RESET prompt. Console Reset erases the settings of the User Profiles and all Workouts.

Note: If you want to reset the Console, push the ENTER button. Push the Increase/Decrease buttons to select the "CONSOLE RESET YES" option, and push ENTER. The Console will reset. Push STOP/PAUSE to return to the Power-Up Mode screen.

15. Push the Right button.

16. The Console displays the SOUND UPGRADE prompt.

Note: If you have an update for the sounds, insert the USB Flash Drive with the update file into the Console and push the ENTER button. Push the Increase/Decrease buttons to select the "SOUND UPGRADE YES" option, and push ENTER. The Console will display "SAVING", and then "REMOVE USB" when it is safe to remove the USB Flash Drive. The Console will exit the Machine Settings Mode and return to the Power-Up Mode screen.

17. Push the Right button to exit the Machine Settings Mode and return to the Power-Up Mode screen.

Read all maintenance instructions fully before you start any repair work. In some conditions, an assistant is required to do the necessary tasks.

**⚠ Equipment must be regularly examined for damage and repairs. The owner is responsible to make sure that regular maintenance is done. Worn or damaged components must be repaired or replaced immediately. Only manufacturer supplied components can be used to maintain and repair the equipment.**

**⚠ DANGER** To reduce the risk of electrical shock or unsupervised usage of the equipment, always unplug the power cord from the wall outlet and/or the machine and wait 5 minutes before cleaning, maintaining or repairing the machine. Place the power cord in a secure location.

**Daily:** Before each use, inspect for loose, broken, damaged, or worn parts. Do not use the machine if any of these conditions exist. After each workout, use a damp cloth to wipe your machine and Console free of moisture.

**Note:** Avoid excessive moisture on the Console.

**Weekly:** Check for smooth roller operation. Clean the machine to remove dust, dirt, or grime. Clean the top of the belt with a slightly damp, soapy cloth and wipe carefully and thoroughly with a dry cloth. Do not let any liquid get below the belts or into the Base Frame.

**Monthly:** Make sure all bolts and screws are tight. Tighten if necessary.

**NOTICE:** Do not clean with a petroleum based solvent or an automotive cleaner. Be sure to keep the Console free of moisture.

## Walking Belt and Deck Lubrication

The TreadClimber® machine is equipped with a low maintenance deck and belt system. Belt friction can affect the function and life of the machine.

### Lubrication Schedule

User Level	Total Workout Hours per Week	When to Lubricate
Light	less than 3 hours	every 3 months
Moderate	3 to 5 hours	every 2 months
Heavy	5 or more hours	every month

We recommend that you use one of the following:

- Lube-N-Walk® Treadmill Lubrication Kit (available from [www.bowflex.com](http://www.bowflex.com) or your local specialty fitness dealer)
- 100% pure silicone, available at most hardware and auto parts stores.

**⚠ Silicone lubricant is not intended for human consumption. Keep out of reach of children. Store in a safe place.**

As you use your fitness machine, the Console will show “NOTE LUBRICATE BELT” followed by “REVIEW USER MANUAL” at set times. This is only a reminder and should be added to your inspection schedule. Only apply lubricant as necessary. Push the ENTER button to accept the reminder.

For the best results lubricate the Treadles periodically with a silicone lubricant, using the following instructions:

1. Unplug the machine fully from the wall outlet, and remove the power cord from the machine. Place the power cord in a secure location.



- Carefully lift each belt and apply silicone lubricant in the center of the Treadle deck along the entire reachable length of the deck. Apply 0.5 to 1.5 oz. of the lubricant on the deck underneath each belt.

**NOTICE:** Always use a 100% pure silicone lubricant. Do not use a degreaser like WD-40® spray lubricant or a petroleum based product as this could seriously impact performance.

**Note:** The Walking Belts may need to be loosened to allow for access during lubrication. Consult the “Adjusting the Walking Belts” procedure if necessary.

- Connect the power cord back into the machine and then into the wall outlet.
- Stay to one side of your machine.
- Switch on your machine and start the belts at the slowest speed. Let the belts operate for approximately 15 seconds.
- Switch off your machine.
- Take care to clean up any excess lubricant from the Treadles. We also recommend a periodic inspection of the Treadle surfaces below the belts. If the decks appear worn, contact a Customer Service Representative.

 **To decrease the possibility of slipping, be sure the Treadle area is free from grease or oil. Clean off any excess oil from the machine surfaces.**

## Walking Belt Alignment

The walking belts need to be adjusted if they are out of center enough to cause a rubbing or scraping sound. Adjustments can be made at the Front Roller of each Treadle.

**Adjusting the Walking Belts** – While operating the machine, notice where the belts run on each Treadle. The Walking Belt Adjustment Bolts are on the front end of each Roller. If the belt is tracking too far to the right, use a properly sized Hex Key to turn the right adjustment bolt clockwise on that belt in full turn increments. If the belt tracks too far to the left, do the same thing on the left adjustment bolt.

**Note:** Do not turn the bolts counterclockwise when you adjust the belt alignment.

**Belt Tension Adjustment** – Check the belt tension only when the machine is unplugged. From the belt's midpoint, a correctly tensioned belt should only have an inch of give. To check, pull the belt upward at its midpoint and measure the distance to the deck. If the distance is more than an inch, the belt is loose. To tighten, turn both Walking Belt Adjustment Bolts clockwise one-half a turn and check tension again. Repeat this step if necessary.

**Note:** Bolts are turned counterclockwise equally to decrease belt tension.

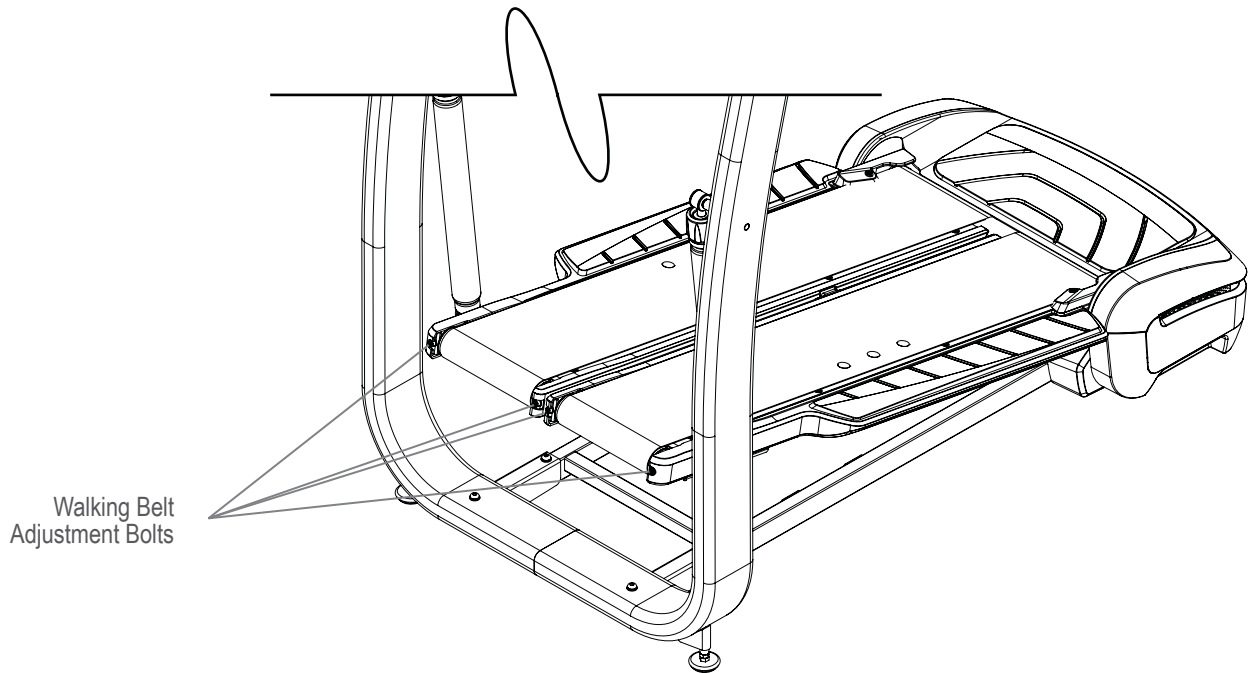

# Maintenance Parts

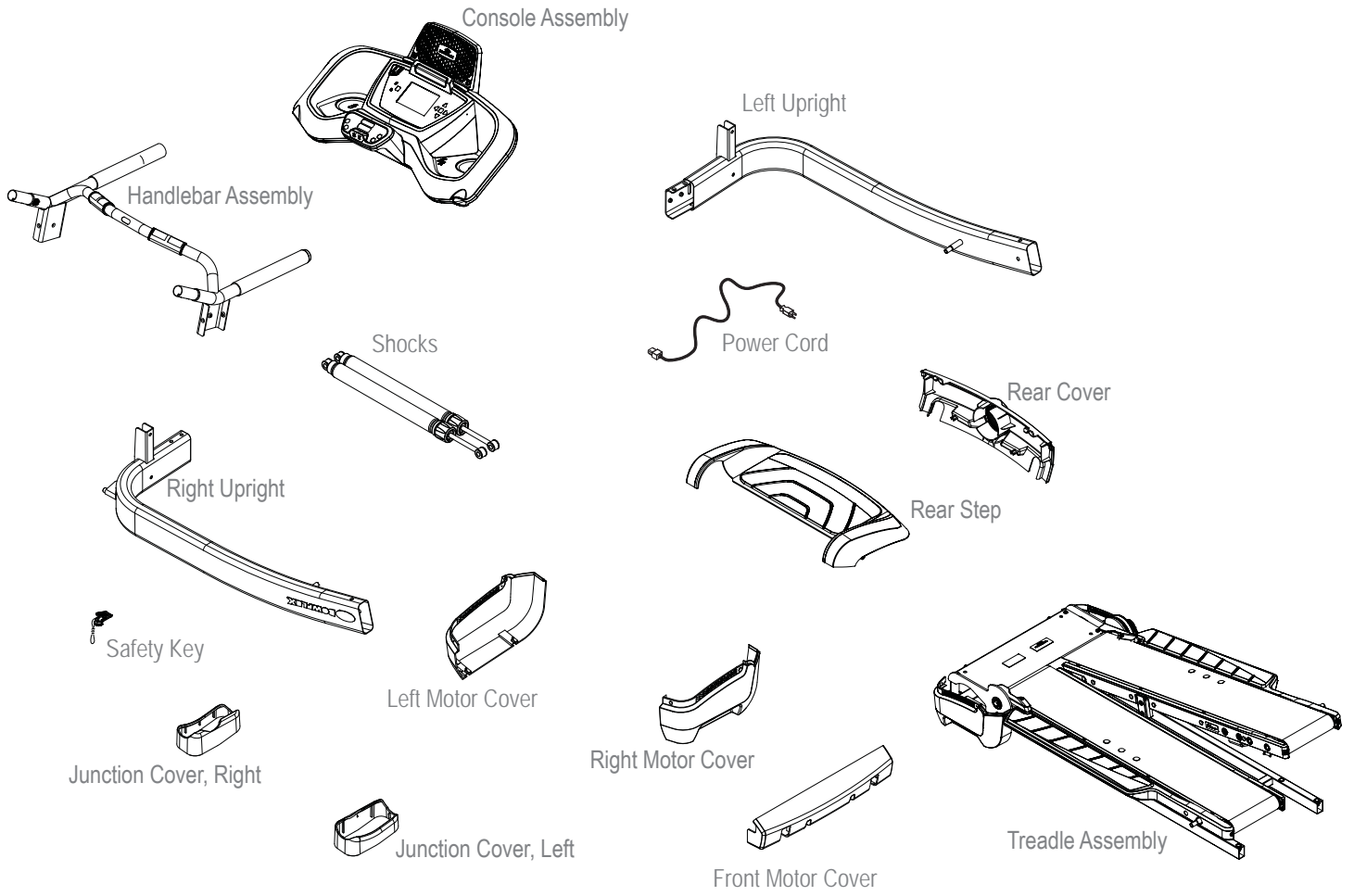

## Maintenance Parts (Treadle Assembly)

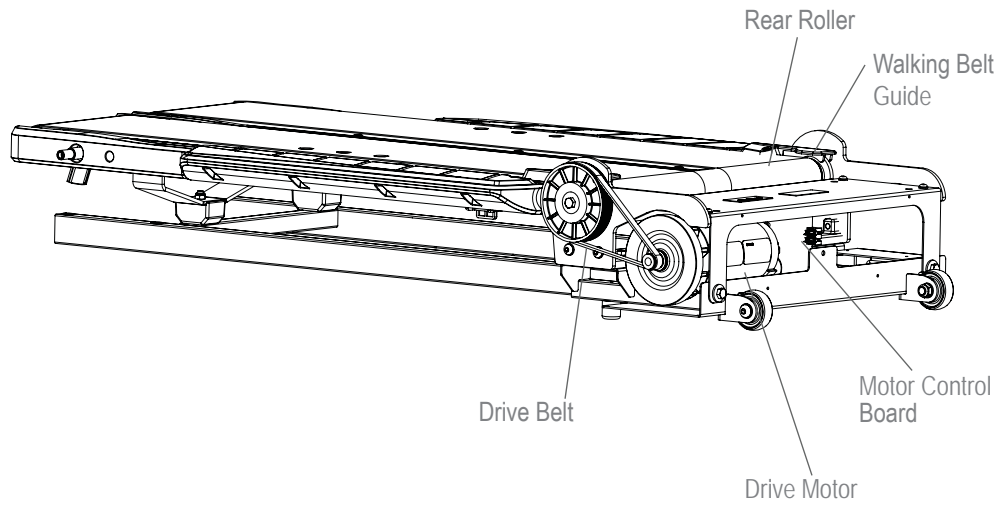
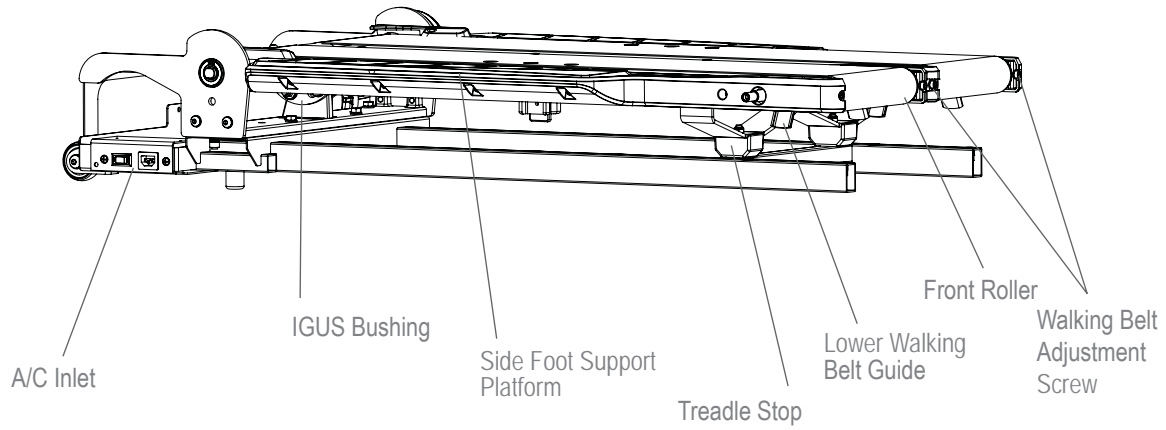

# Troubleshooting

Condition/Problem	Things to Check	Solution
Unit will not power up/turn on/start	Outlet	Make sure outlet is functioning correctly. Verify this by plugging another device (ex: lamp) into the outlet. If outlet is connected to a light switch, check to make sure it is on. If outlet is not functioning find a working outlet.
	Power cord not plugged in	Make sure the power cord is firmly secured to A/C inlet on the unit and firmly inserted into a non-GFI/AFCI wall socket.
	Power switch turned off	Make sure the power switch at the right side of the unit is in the "ON" position. Switch will light up red to indicate power is present.
	Safety key not plugged in	Plug Safety Key into Console (See Emergency Stop Procedure).
	If problem persists	Contact Customer Service.
Speed displayed is not accurate	Display set to wrong unit of measure. (English/Metric)	Change display units in the User Profile settings.
Walking belt misalignment	Rear belt guides	Belts should ride on top of triangular black belt guides at rear of treadles.
	Tracking adjustment	Belts are not required to be perfectly centered and are typically farther out in the rear than they are in the front. This may vary depending on user's stride. If belt is tracking to one side far enough to cause rubbing of belt, consult the "Adjusting the Walking Belts" procedure.
Speed dependent grinding or scraping noise	Belt alignment	Check walking belt alignment. Belt contact with metal guides under Treadle can make a loud grinding sound. If belts are misaligned, adjust walking belt.
	Rollers or motor	Contact Customer Care for further assistance.
Hesitation or belt slipping when walking on unit	Walking belt tension	Adjust walking belt tension by following the "Adjusting the Walking Belt" procedure.
Knocking noises when unit is operating	Igus bushing	If knocking sound seems to be coming directly from the rear roller, check Igus (white "hat" shaped) bushings and replace if cracked.
	Shock bolts	Check and tighten both upper and lower bolts that connect the shocks to the unit.
Belts stop turning while in use	Safety key	Plug Safety Key into Console (See Emergency Stop Procedure in Safety Warning Labels section).
	Motor overload	Unit may be overloaded and drawing too much current, causing unit to shut power down to protect motor. Consult belt lubrication schedule to determine if belts need lubrication, check walking belt tension, and restart unit.
	Outlet	Outlet may not have enough power available for the machine due to other devices on same circuit. Remove any devices from power circuit and restart machine.
Console displays "INSERT SAFETY KEY"	Safety Key	Insert Safety Key into Safety Key Port on Console.
Console displays "NOTE LUBRICATE BELT" followed by "REVIEW USER MANUAL"	Belt lubrication	Consult lubrication schedule and apply if necessary. Push ENTER button to exit the notice.
Console displays "ERROR COMMUNICATION" followed by "RESTART MACHINE"	I/O Cables	Restart machine. If error persists, contact Customer Service for further assistance.
Console displays "ERROR MOTOR BOARD" followed by "CONTACT SUPPORT"	Motor Control Board	Contact Customer Service for further assistance.

Console displays "ERROR OVERLOAD" followed by "COOL DOWN 20 MIN"	Motor Covers	Cycle power off and allow the machine to cool down for at least 20 minutes. Be sure the Motor Cover vents are free of debris. If issue recurs contact Customer Service for further assistance.
Console displays "ERROR MOTOR WIRE" followed by "CONTACT SUPPORT"	Motor Connections	Contact Customer Service for further assistance.
Console displays "ERROR STUCK BUTTON" followed by "Name of BUTTON"	Specified button	Release specified button. If error persists, make note of the stuck button and contact Customer Service for further assistance.
Console displays "PLEASE CYCLE POWER" and one of the following: "MCB COMM LOST", "MCB RELY STUCK CLSD", "MCB RELY STUCK OPEN", "MCB TACH OVER SPEED", "MCB TACH TIMEOUT", "MCB COMM TIMEOUT", "MCB OVER CURREN SOC", "MCB OVER CURRE CRIT", "MCB OVER CURRE DMAG", and "MCB HW OVERS SPEED"	Motor Control Board	Restart machine. If error persists, contact Customer Service for further assistance.

# Bowflex™ Body Weight Loss Guide

## Introduction and Overview

Welcome to the Bowflex™ Body Weight Loss Guide. This guide is designed to be used with your Bowflex® equipment and will help you:

- Lose weight and get lean
- Improve your health and wellness
- Increase your energy and vitality

**⚠ Consult a physician before you start an exercise program or a new health and diet plan. Stop exercising if you feel pain or tightness in your chest, become short of breath, or feel faint. Contact your doctor before you use the machine again. Use the values calculated or measured by the machine's computer for reference purposes only. The heart rate displayed on the console is an approximation and should be used for reference only.**

By focusing on the main three elements of the Bowflex™ Body Weight Loss Guide- quality, balance, and consistency- you'll be able to reach and maintain your weight loss and fitness goals for the next six weeks and beyond.

- **Quality** – The emphasis of this plan is on eating more whole foods and getting the most nutrients from your calories as possible. Making the majority of your diet from foods that have a single ingredient (for example fruits, vegetables, fish, lean protein, eggs, beans, nuts, and whole grains) provides the vitamins, minerals, fiber, protein, and healthy fats your body needs.
- **Balance** – Each of the meals and snacks in this guide have a source of fiber or smart carbohydrate, protein, and healthy fat to keep your energy levels consistent throughout the day to fuel your workouts. By having this balance you'll feel fuller longer, which is critical to weight loss success.
- **Consistency** – Getting about the same number of calories each day is important for your metabolism and your mindset. If you overdo it one day, don't try to make up for it the next day by not eating or cutting your calories drastically. Get right back on track by following this guide!

## Results & Expectations

Results will vary depending on your age, starting weight, and exercise level. By adhering to a diet and exercise routine, you may lose 1-3 lbs per week and experience increased energy levels.

## 5 Tips for Long-Term Success

1. **Keep a food log** including hunger levels and water intake. Free online food logs and mobile apps are available at [www.myfitnesspal.com](http://www.myfitnesspal.com) and [www.loseit.com](http://www.loseit.com)
2. **Weight and/or take measurements weekly** – no more and no less. Weighing weekly rather than daily or every other day is best. You'll track your progress and keep yourself in check without getting discouraged if the scale doesn't move for a few days. And remember, weight is just a number and it's influenced by muscle gain as well as fat loss. Feeling how your clothes fit can often be a better indicator of progress as your body adapts to exercise and nutrition changes.
3. **Measure portions** – To avoid portion creep, use measuring cups and spoons for grains (rice, pasta, cereal), beans, nuts, oils, and dairy. Use the Portion Sizes Guide for other foods.
4. **Plan ahead** – Make a meal plan for the week or log your food a day in advance. Planning sets you up for success, especially for social events and eating out.
5. **Practice your desired long-term habits** – It's easy to justify poor eating choices when you're only focused on the short term. Focus on the long term satisfaction of a slimmer, healthier you rather than the temporary gratification you'll get from splurging.

## How to Use this Guide

- **Eat breakfast within 90 minutes of waking up and balance your meals and snacks throughout the day**
  - Don't go longer than 5-6 hours without eating
  - If you're not used to eating breakfast, start out small with a piece of fruit and have something else 1-2 hours later. Your body adapts to not eating breakfast, but as soon as you start eating early in the day and cutting back on dinner portions you'll notice your hunger will increase. This is a good sign your metabolism is working!
- **Mix and match meal options**
  - Select 1 option from the appropriate meal plan (male or female) for breakfast, lunch, and dinner, paying close attention to portion sizes
  - Select 1-2 snack options per day
  - You have the option to substitute one snack for one treat under 150 calories
  - Use the meal plan, sample options, and grocery list to create your own meals for more variety

- You can swap out any type of protein, vegetables or smart carbs for the suggested meal options. For example:
  - Turkey for tuna
  - Any fish or seafood for chicken
  - Cooked vegetables instead of salad
- **Eat your calories**
  - Cut out high calorie beverages like soda, juices, coffee drinks, and alcohol
  - Stick with water, unsweetened tea, and coffee. Aim for a minimum of 64oz (1.9 liters) of water per day to stay well hydrated
- **If you're still hungry after or in between meals:**
  - Have a glass of water and wait 15-20 minutes. Many times we mistake thirst (or even boredom!) for hunger. Wait out the initial urge to eat and sometimes it will pass.
  - If you're still hungry after waiting 15-20 minutes have a snack or mini-meal with fruit, vegetables, and protein.

**If your goal is muscle gain or strength:**

- Use the same meal plan but increase portion sizes in the same ratios to increase the total number of calories you eat every day. For example, increase portion sizes of protein and smart carbs at meals by 50%. Adding a snack is another option to meet your body's increased calorie needs in order to gain muscle and strength.
- Focus on post-workout nutrition by having one of your snacks within 30 minutes after you complete your workout. Make sure to have a combination of carbohydrates such as fruit with protein (yogurt, milk, or protein powder) to promote muscle growth and recovery. Chocolate milk is also a great option.

## Meal Plan Overview

The female meal plan provides about 1400 calories, and the male plan provides about 1600 calories, of high quality nutrition to not only help you lose weight and feel great but get the most out of your calories. The vitamins, minerals, and antioxidants from eating mostly whole foods help support optimal health. These calorie levels will result in healthy weight loss for the majority of people. Keep in mind that everyone's metabolism is very different depending on age, height, weight, activity level, and genetics. Pay close attention to your weight, hunger levels, and energy and adjust your calories if needed.

**Follow these guidelines if you're over 55:**

- If you're over 55, you need fewer calories because your metabolism slows as you age. Stick with three meals with one optional snack per day.

**Follow these guidelines if you're under 25:**

- If you're under 25 you may need more calories. Add another snack if you feel low on energy or are extremely hungry.

## Breakfast

Breakfast includes a smart carb, fruit, and a source of protein, which will also have fat. With a balance of carbohydrates and fiber from the smart carb and fruit combined with protein and fat, you'll energize your day and help control hunger levels throughout the day.

## Snacks

Each snack is a balance of carbohydrates and protein to keep your blood sugar more consistent, which means you won't experience hunger and energy level spikes and drops.

This happens when you have a high carb-only snack like chips, candy, soda, crackers, or pretzels.

## Lunch and Dinner

Lunch combines filling fiber from vegetables and smart carbs with a lean, or low-fat, protein. The healthy fat can come either from the protein added during cooking (nuts on a salad) or as a dressing or sauce (such as oil and vinegar salad dressing).



Here's an overview of what an ideal day looks like:  
(See Portion Size Guide for proper serving sizes)

### Breakfast

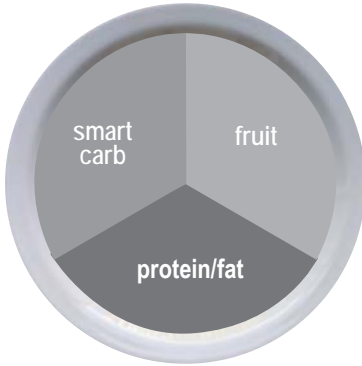

### Snack #1

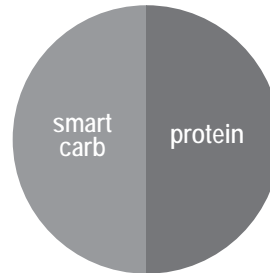

### Lunch

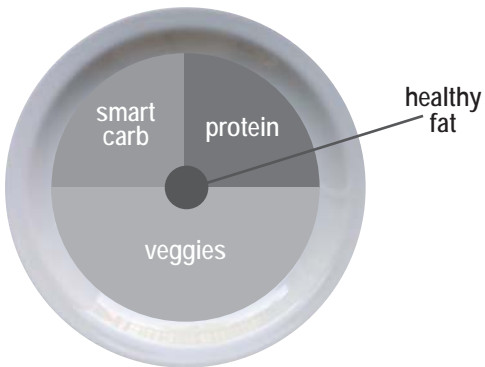

### Snack #2

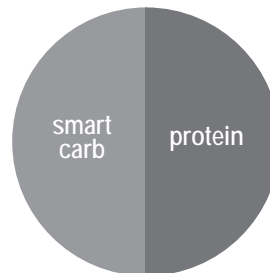

### Dinner

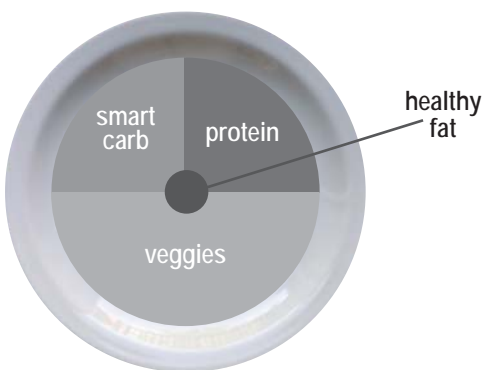

Breakfast Options	Fruit	Smart Carb	Protein/Fat
<b>Fruit and Nut Oatmeal</b> Cook plain oats in water. Top with fruit, nuts, milk, cinnamon, and honey.	Berries or banana	Plain oats (Regular or quick-cook)	Nuts and milk
<b>Egg Muffin</b> Cook egg/s. Toast bread and top with 1 slice of cheese, 1 slice of ham, and tomato.	Tomato	English muffin or sandwich thin	Egg, ham, and cheese
<b>Yogurt Power Parfait</b> Top yogurt with fruit. Sprinkle with 1 serving of nuts, 2-3 tbsp wheat germ, or ground flaxseed, 1 tbsp oats, and cinnamon.	Chopped fruit of your choice	Oats, wheat germ, and ground flaxseed	Plain non-fat Greek yogurt and nuts
<b>On the Go PB &amp; Apple Sandwich</b> Toast bread. Spread on peanut butter, thin slices of ½ an apple, and 1 teaspoon of honey.	Sliced apple	Sandwich thin, bread, or bagel thin	Peanut butter

Lunch & Dinner Options	Lean Protein	Smart Carb	Veggies
<b>Pork Loin, Sweet Potato &amp; Green Beans</b>	Grilled or baked pork loin	Baked Sweet Potato	Green Beans
<b>Chicken Stir Fry</b> Flavor with 2 tablespoon teriyaki sauce	Chicken breast or boneless skinless thigh	Brown or wild rice	Mixed stir fry vegetables (fresh or frozen)
<b>Steak Tacos with Side Salad</b> (3 for males, 2 for females) Top with salsa, cilantro, and sprinkle of shredded cheese	Flank or sirloin steak	Corn tortillas	Salad
<b>Whole Wheat Pasta with Shrimp or Cannellini Beans &amp; Marinara Sauce</b>	Shrimp (frozen or fresh) or cannellini beans	Whole wheat pasta	Steamed broccoli
<b>Bunless Burgers with Oven Fries, Corn, &amp; Salad</b> Grill burgers. Bake sliced potatoes on sprayed cookie sheet for 25-30 minutes @ 425°F.	93% lean ground beef or turkey	Oven baked fries	Corn on the cob + side salad
<b>Tuna &amp; Avocado Wrap with Vegetable Soup</b> Use 3oz of tuna (1 can). Top with lettuce, tomato, avocado, and mustard.	Tuna	High-fiber wrap	Vegetable soup (homemade or low-sodium canned)

Snack Options	
Smart Carb	Protein
1 medium apple	10-15 almonds
Baby carrots	2 tbsp hummus
1 serving of crackers*	1 string cheese
Energy or protein bar with <200 calories*	

\*See [www.Bowflex.com/Resources](http://www.Bowflex.com/Resources) for brand recommendations

## Optional Treats

You have the choice of replacing Snack #2 with a 100-150 calorie treat. You can have an optional treat every day but for optimal health it is recommended to limit small splurges to 3-4 times per week. Use the approach that works best for you. Here are a few examples:

- ½ cup lowfat ice cream
- 1 small bag of baked potato chips
- 4oz of wine or 12oz light beer
- 3 cups of air-popped or light popcorn

## Sample 3 Day Plan

Based on each of the meal options listed above, a typical 3 day plan could look like this:

	Day 1	Day 2	Day 3
Breakfast	Egg muffin	Power yogurt parfait	Fruit + nut oatmeal
Snack 1	Apple with almonds	Nut Thins® + string cheese	Baby carrots and hummus
Lunch	Tuna & avocado wrap with soup	Leftovers from dinner- day 1	Leftovers from dinner- day 2
Optional Snack 2 or Treat	½ cup ice cream bar	Energy bar	100 calorie bag of light popcorn
Dinner	Shrimp pasta	Chicken stir fry	Bunless burgers

## Portion Size Guide

Each of the items listed are for one serving

MALE	FEMALE
<b>PROTEIN</b>	
2 eggs 5oz chicken, fish, lean meat, or tofu 2/3 cup beans or lentils* 1 cup greek yogurt* 1.5oz cheese*	1 egg 3oz chicken, fish, or lean meat 1/2 cup beans or lentils* 1/2 cup greek yogurt* 1.5oz cheese*
<b>HEALTHY FAT</b>	
2 Tblspn peanut or nut butter* 2 tspn olive, flax, or walnut oil 1/4 cup of nuts 1/3 medium avocado	1 tblspn peanut or nut butter* 1 tspn olive, flax or walnut oil 1/8 cup or 2 tablespoons of nuts (approx. 15 almonds) 1/4 medium avocado
<b>SMART CARB</b>	
1 cup cooked grains (1/2 cup raw): oats, brown rice, quinoa, pasta 1 medium sweet or regular potato 2 corn tortillas 1 slice of bread (or 2 light slices equaling 120 calories or less) 1 english muffin, sandwich thin, or high-fiber wrap	1/2 cup cooked (1/4 cup raw) grains 1/2 medium sweet potato or regular potato 2 corn tortillas 1 slice of bread (or 2 light slices equaling 120 calories or less) 1 english muffin, sandwich thin, or high-fiber wrap
<b>FRUIT</b>	
1 medium apple, orange, or pear 1 small banana (length of your hand) 1 cup berries or chopped fruit 1/4 cup dried fruit (fresh or frozen is optimal)	
Vegetables* You can have unlimited vegetables except for peas and corn; stick with 1/2 cup serving	
2 cups spinach or lettuce = 2 cupped hands 1 cup raw vegetables 1/2 cup cooked vegetables 6oz low sodium vegetable juice	
<b>OPTIONAL TREATS</b>	
1/2 cup lowfat ice cream 1 small bag of baked potato chips 1oz dark chocolate 4oz of wine or 12oz light beer 3 cups air-popped or light popcorn	

\* some foods are a combination of protein and carbs or protein and fat



1 cup = baseball



1/2 cup = lightbulb



1 oz or 2 tbsp = golf ball

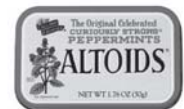

1/4 cup nuts = Altoids tin



3 oz chicken or meat = deck of cards



1 medium potato = computer mouse



1 medium piece of fruit = tennis ball



1 - 1/2 oz cheese = 3 dice

## Grocery List

<b>BREAD &amp; GRAINS</b>							
100% whole wheat bread Sprouted grain breads Light or whole wheat english muffins Sandwich or bagel thins Corn or low-carb whole wheat tortillas High-fiber wraps Plain oats: 1 minute or old fashioned Whole grains: brown rice, bulgar, barley, quinoa, couscous	Tips: Look for 100% whole wheat as the first ingredient. Look for 4g of fiber per slice or 5g per 2 slices of light or diet bread. Aim for bread with less than 100 calories per slice.						
<b>DAIRY &amp; DAIRY ALTERNATIVES</b>	<b>CRACKERS, SNACKS &amp; ENERGY BARS</b>						
Plain non-fat greek yogurt Kefir (yogurt like drink) Organic low-fat milk Enriched almond or soy milk Cheese: feta, parmesan, mozzarella, light havarti, provolone, swiss, string cheese, or single serving packages	<table border="1"> <tr> <td>Any unsalted nuts or seeds</td> <td>Energy bars</td> </tr> <tr> <td>Air-popped or light popcorn</td> <td>Crackers</td> </tr> <tr> <td>Edamame in the pod</td> <td>Hummus</td> </tr> </table>	Any unsalted nuts or seeds	Energy bars	Air-popped or light popcorn	Crackers	Edamame in the pod	Hummus
Any unsalted nuts or seeds	Energy bars						
Air-popped or light popcorn	Crackers						
Edamame in the pod	Hummus						
<b>MEAT, FISH, POULTRY &amp; PROTEIN</b> Wild game Salmon, halibut, tuna, tilapia, shrimp, catfish, scallops, or crab Pork loin, pork chops, or pork roast Chicken or turkey breast or thighs (no skin) Eggs and 100% egg whites Lean beef: sirloin, chuck, round, tenderloin, 93% lean (organic and grass fed is best) Canned salmon or tuna (in water) Nitrate-free, reduced sodium ham, turkey, chicken, or roast beef lunch-meat Any type of bean, dry or canned low-sodium varieties Tofu and tempeh Tips: Look for "Choice" or "Select" cuts of meat rather than "Prime". Prime cuts are fattier. Limit intake of highly processed meat and imitation meat products like sausage, bacon, pepperoni, and hot dogs to once a week or less.	Tips: Limit crackers, pretzels, and chips to 2-3 servings per week. Always pair with protein such as hummus, cheese, or nuts. Look for energy bars with less than 200 calories and 20g of sugar and at least 3g of protein and 3g of fiber. Look for crackers with less than 130 calories and 4g or less of fat per serving.						
<b>FROZEN FOODS</b> All vegetables without sauce All fruit Grains and grain medleys	<b>FATS &amp; OILS</b> Avocado Olive, grapeseed, walnut, sesame, or flaxseed oil Butter/spreads: look for products free of trans fats and partially hydrogenated oils on the ingredient list. Tips: Light olive oil refers to the flavor, not the calorie content. Always measure oil and butter. Even if a fat is considered healthy, it's still very high in calories and portions need to be controlled.						
	<b>DRESSINGS, CONDIMENTS &amp; SAUCES</b> Vinegars: rice, wine, balsamic All fresh or dried herbs and spices Mustard Salsa and chili sauce Marinara sauce with no high-fructose corn syrup Lemon and lime juice Bottled minced garlic and ginger Low-sodium soy sauce Tips: Look for products free of MSG, added colors, and high fructose corn syrup. Look for sauces under 50 calories per serving. Avoid cream based sauces and dressings like ranch, bleu cheese, and alfredo.						

All fruits and vegetables, fresh and frozen, are great choices. Since every meal has one or both, your shopping cart should reflect this.

## Keep It Going

### Tips for continued weight loss and maintaining changes

- **Keep weighing yourself weekly**, even after you've reached your goal weight
- **Continue keeping a food log.** If you have your meal plan well-established, log your food every other week to keep yourself on track. Don't feel like you have to do it every day.
- **Prepare for plateaus.** The scale might not budge for a few weeks or even months after some initial weight loss. This is normal and to be expected. It's the body's natural process for adjusting to your new lower weight. Stay focused on your long-term goal, celebrate your successes and changes, and mix up your workouts to help overcome the plateau.
- **Calorie adjustments for maintaining weight loss.** Once you've reached your goal weight, you can increase your calories 100-200 per day as long as your activity level stays the same
- **Treat yourself.** Have a non-food reward for each goal you hit such as a massage, a new outfit, or an outing with friends and family
- **Use the resources below** to find new recipes, get expert advice, and support to stay motivated

## Resources

### Downloadable Resources from Bowflex™ Website ([www.Bowflex.com/Resources](http://www.Bowflex.com/Resources))

- Grocery Shopping List for Fridge (Blank Form)
- 7 Day Meal Planning Form
- Additional Dinner Options
- Pre and Post Workout Fueling Guide

### Questions & Support

- Ask questions, post suggestions, and connect with our online Bowflex™ Dietitian on the Bowflex Facebook page

### Recipes

- [www.wholeliving.com](http://www.wholeliving.com)
- [www.eatingwell.com](http://www.eatingwell.com)
- [www.whfoods.org](http://www.whfoods.org)
- [www.livebetteramerica.org](http://www.livebetteramerica.org)

### Online food logs

- [www.myfitnesspal.com](http://www.myfitnesspal.com)
- [www.loseit.com](http://www.loseit.com)







# Buy Back Guarantee

We want you to know that your TreadClimber® machine is a superior product. Your satisfaction is guaranteed. If, for any reason, you are not 100% satisfied with your TreadClimber® machine, please follow the instructions below to return your merchandise and receive a refund of the purchase price, less shipping and handling.

This TreadClimber® Buy Back Guarantee applies only to merchandise purchased by consumers directly from Nautilus, Inc. This guarantee does not apply to sales made by dealers or distributors.

1. Call a TreadClimber Representative at 1-800-605-3369 for a Return Authorization Number (RMA). An RMA will be granted if:
  - a. The TreadClimber® exercise machine was purchased directly from Nautilus, Inc.
  - b. The request to return the product is within 6 weeks of the delivery date of your merchandise.
2. If an RMA is granted, the following instructions will prevent delays in the processing of your refund.
  - a. The merchandise must be returned to the address given to you at the time of the Return Authorization Call.
  - b. All returned merchandise must be properly packaged in good condition, preferably in the original boxes.
  - c. The exterior of the boxes should be marked clearly with:
    - Return Authorization Number
    - Your Name
    - Your Address
    - Your Phone Number
  - d. Additionally, a piece of paper with your name, address and phone number or copies of your original invoice should be placed in each box of merchandise.
  - e. **Your RMA number is time sensitive.** Your shipment must be post marked within two weeks from the date the TreadClimber Representative issued the Return Authorization Number.

**Note:** You are responsible for return shipping and for any damage or loss to merchandise that occur during return shipment. Nautilus recommends that you obtain tracking numbers and insure your shipment.

## Unauthorized Returns

Nautilus, Inc. defines an unauthorized return as any merchandise returned to our facilities without a valid and current Return Merchandise Authorization (RMA) number issued by Nautilus. Failure to properly mark packages with a valid RMA number, or allowing an RMA number to expire, will cause Nautilus, Inc. to consider a return unauthorized. Any merchandise returned without a RMA number will not be subject to a refund or credit and Nautilus will discard the product. The customer assumes all shipping and handling charges for any unauthorized return.

## Who Is Covered

This warranty is valid only to the original purchaser and is not transferable or applicable to any other person(s).

## What Is Covered

Nautilus, Inc. warrants that this product is free from defects in materials and workmanship, when used for the purpose intended, under normal conditions, and provided it receives proper care and maintenance as described in the Product's Assembly and Owner's manual. This warranty is good only for authentic, original, legitimate machines manufactured by Nautilus, Inc. and sold through an authorized agent and used in the United States or Canada.

## Terms

- Frame 2 years
- Mechanical parts 2 years
- Electronics 2 years
- Shocks 2 years
- Motor 2 years
- All other components 2 years
- Labor 90 days

(Labor support does not include the installation of replacement parts involved in the initial product assembly and preventative maintenance services. All repairs covered under the labor portion of the warranty must be preauthorized by Nautilus.)

## How Nautilus Will Support the Warranty

Throughout the terms of the warranty coverage, Nautilus, Inc. will repair any machine that proves to be defective in materials or workmanship. Nautilus reserves the right to replace the product in the event a repair is not possible. When Nautilus determines replacement is the correct remedy, Nautilus may apply a limited credit reimbursement toward another Nautilus, Inc. brand Product, at our discretion. This reimbursement may be prorated based on length of ownership. Nautilus, Inc. provides repair service within major metropolitan areas. Nautilus, Inc. reserves the right to charge the consumer for travel outside these areas. Nautilus, Inc. is not responsible for dealer labor or maintenance charges beyond the applicable warranty period(s) stated herein. Nautilus, Inc. reserves the right to substitute material, parts or products of equal or better quality if identical materials or products are not available at the time of service under this warranty. Any replacement of the product under the terms of the Warranty in no way extends the original Warranty period. Any limited credit reimbursement may be prorated based on length of ownership. THESE REMEDIES ARE THE EXCLUSIVE AND SOLE REMEDIES FOR ANY BREACH OF WARRANTY.

## What You Must Do

- Retain appropriate and acceptable Proof of Purchase.
- Operate, maintain, and inspect the Product as specified in the Product Documentation (Assembly, Owner's Manuals, etc.).
- Product must be used exclusively for the purpose intended.
- Notify Nautilus within 30 days after detecting an issue with the Product.
- Install replacement parts or components in accordance with any Nautilus instructions.
- Perform diagnostic procedures with a trained Nautilus, Inc representative if requested.

## What Is Not Covered

- Damage due to abuse, tampering or modification of the Product, failure to properly follow assembly instructions, maintenance instructions, or safety warnings as stated in the Product Documentation (Assembly, Owner's Manuals, etc), damage due to improper storage or the effect of environmental conditions such as moisture or weather, misuse, mishandling, accident, natural disasters, power surges.
- A machine placed or used in a commercial or institutional setting. This includes gyms, corporations, work places, clubs, fitness centers and any public or private entity that has a machine for use by its members, customers, employees or affiliates.
- Damage caused by exceeding maximum user weights as defined in the Product's Owner's manual or warning label.
- Damage due to normal usage and wear and tear.
- This warranty does not extend to any territories or countries outside the United States and Canada.

## How to Obtain Service

For Products purchased directly from Nautilus, Inc. contact the Nautilus office listed on the Contacts page of the products Owner's manual. You may be required to return the defective component to a specified address for repair or inspection, at your expense. Standard ground shipping of any warranty replacement parts will be paid by Nautilus, Inc. For products purchased from a retailer, you may be asked to contact your retailer for warranty support.

## Exclusions

The preceding warranties are the sole and exclusive express warranties made by Nautilus, Inc. They supersede any prior, contrary or additional representations, whether oral or written. No agent, representative, dealer, person or employee has the authority to alter or increase the obligations or limitations of this warranty. Any implied warranties, including the WARRANTY OF MERCHANTABILITY and any WARRANTY OF FITNESS FOR A PARTICULAR PURPOSE, are limited in duration to the term of the applicable express warranty provided above, whichever is longer. Some states do not allow limitations on how long an implied warranty lasts, so the above limitation may not apply to you.

## Limitation of Remedies

EXCEPT AS OTHERWISE REQUIRED BY APPLICABLE LAW, THE PURCHASER'S EXCLUSIVE REMEDY IS LIMITED TO REPAIR OR REPLACEMENT OF ANY COMPONENT DEEMED BY NAUTILUS, INC. TO BE DEFECTIVE UNDER THE TERMS AND CONDITIONS STATED HEREIN. IN NO EVENT WILL NAUTILUS, INC. BE LIABLE FOR ANY SPECIAL, CONSEQUENTIAL, INCIDENTAL, INDIRECT OR ECONOMIC DAMAGES, REGARDLESS OF THE THEORY OF LIABILITY (INCLUDING, WITHOUT LIMITATION, PRODUCT LIABILITY, NEGLIGENCE OR OTHER TORT) OR FOR ANY LOST REVENUE, PROFIT, DATA, PRIVACY OR FOR ANY PUNITIVE DAMAGES ARISING OUT OF OR RELATED TO THE USE OF THE FITNESS MACHINE EVEN IF NAUTILUS, INC. HAS BEEN ADVISED OF THE POSSIBILITY OF SUCH DAMAGES. THIS EXCLUSION AND LIMITATION SHALL APPLY EVEN IF ANY REMEDY FAILS OF ITS ESSENTIAL PURPOSE. SOME STATES DO NOT ALLOW THE EXCLUSION OR LIMITATION OF CONSEQUENTIAL OR INCIDENTAL TYPE DAMAGES SO THE ABOVE LIMITATION MAY NOT APPLY TO YOU.

## State Laws

This warranty gives you specific legal rights. You may also have other rights, which vary from state to state.

## Expirations

If the warranty has expired, Nautilus, Inc. may assist with replacements or repairs to parts and labor, but there will be a charge for these services. Contact a Nautilus office for information on post-warranty parts and services. Nautilus does not guarantee availability of spare parts after expiration of warranty period.

## International Purchases

If you purchased your machine outside of the United States consult your local distributor or dealer for warranty coverage.

