

Max Trainer M6: My machine is seized, why won't it move?

ID: 11207.3

Follow this troubleshooting guide to help resolve issues involving a seized-up Max Trainer M6.

Some common complaints may include:

- Pedals are stuck and won't move
- Fan making contact with the motor or frame
- Jammed upper or lower belts

Pedals are stuck and won't move

Tools you may need:

Phillips head screwdriver
5mm, 6mm hex/Allen wrenches, or Allen wrenches from the hardware card included with your machine
14mm socket wrench
Crank puller (if removing crank arms for troubleshooting)
Flashlight

1. Check that the crank arms are opposite each other 180 degrees (**reference 1**). If the crank arms are not inline and opposite each other, reorient the crank arms following the "Replace the Crank Arms" section of the **[service manual \[11207.A\]](#)**.

(Reference 1)

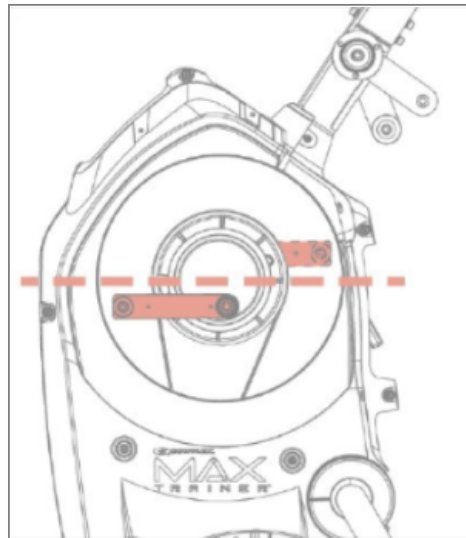

Diagram showing how the crank arms should be oriented when properly installed.

2. Check if the crank arms can be rotated by hand. Applying weight to the raised foot pedal can help with pedals that have bottomed out **[\[11207.B\]](#)**.
3. Remove the lower right fan shroud. Watch the video below or follow the instructions starting in the next step.

Bowflex® Max Trainer | Removing Lower Right Fan Shroud



([BowFlex® Max Trainer | Removing Lower Right Fan Shroud](#))

- Using a Phillips head screwdriver, carefully remove the upper 3 screws and loosen the lower screw by at least 3 full rotations. **The power plug wire inlet is attached to the inside and needs to be gently unplugged before completely removing the cover (reference 2).** It may help if you tilt the machine gently to the side to loosen the bottom screw.

(Reference 2)

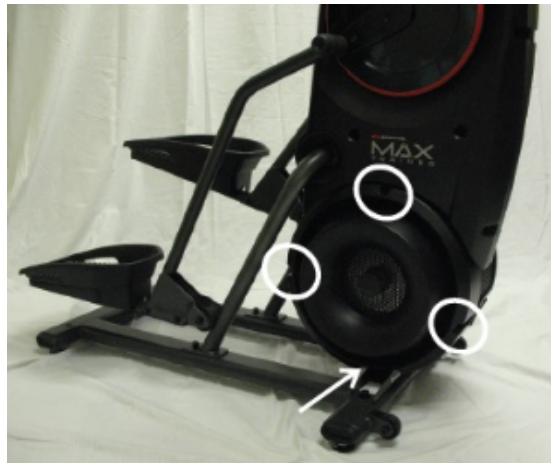

The white arrow indicates the location of the power plug wire inlet and bottom screw. The bottom screw can be loosened 3 turns rather than removing it entirely. The white circles indicate the locations of the screws to remove in order to remove the cover.

- Check if the magnets are stuck to the brake disc. If the magnets are stuck to the brake disc, please visit [Max Trainer M6: My machine is making a metallic grinding or scraping noise](#) to continue troubleshooting.
- If the issue persists, attempt to spin the fan by hand back and forth. Inspect the 4 round magnets located on the fan. If these magnets are making contact with the motor or the frame, [order an Engine \[11207.C\]](#).
- Inspect the lower belt for damage. If damage is present or has become jammed in the frame, [order a Lower Belt \[11207.D\]](#).
- Inspect the upper belt for damage. Using a 6mm Allen wrench, remove the left pedal arm. Once the pedal arm is removed, remove the left side crank cover with a Phillips head screwdriver. This will expose the left crank and the upper belt pulley. You may need to use a flashlight to see the belt easier. If the upper belt is damaged or has become jammed in the frame, [order an Upper Belt \[11207.E\]](#).

Need to order replacement parts?

1 Customer Care Contact Information

Please contact Customer Care at [1-800-605-3369](tel:1-800-605-3369) for additional help or to order replacement parts. Some replacement parts may also be available for purchase [online here](#). A list of part numbers referenced within this guide can be located at the bottom of this page.

Customer Care - Hours of Operation:

Monday - Friday 6:00am - 5:00pm PST

The replacement part will be provided to you at no cost assuming your machine meets the warranty eligibility requirements. A Customer Care Agent will be able to assess your current warranty eligibility and provide you with your options.

Please note that if you did not purchase your machine directly from BowFlex, Schwinn, or Nautilus, we will need a copy of your purchase receipt in order to register your machine for warranty.

2 Parts Reference Table

<i>Part Description</i>	<i>Part SKU</i>
Lower Belt	8006063
M6 Engine	8020204
Upper Belt	8004642

3 Contact Tech Team / Advanced Troubleshooting

If the issue was not resolved in the steps listed, contact the Tech Team or send an Advanced Troubleshooting case.

Submit a Case with case type Advanced Troubleshooting