

Schwinn 810: Why is there no power to my machine or console? ID: 12391.1

Follow this troubleshooting guide to help resolve power issues on your Schwinn 810 Treadmill.

Some common complaints may include:

- Console does not power on
- No power to treadmill
- Treadmill won't turn on
- Display is dark
- Console doesn't light up

Follow these steps to troubleshoot the issue

Tools you may need:

Phillips head screwdriver
6mm hex/Allen wrench or the wrench from the hardware card included with your treadmill

1. Unplug the power cord from both the treadmill and the wall outlet. Inspect the entire length of the cord for any damage or crimps. If undamaged, plug the power cord back in at both ends. Make sure it is securely connected. Flip the on/off switch and see if it glows. If damage is present, [order a Power Cord \[12391.A\]](#).
2. If the on/off switch does not glow, confirm that the wall outlet is working properly. The power cord must be plugged directly into a 3-prong outlet without the use of extension cords. Plug another device into the outlet, such as a lamp, to see if it turns on. If it is not working, try again with a working outlet [\[12391.B\]](#). If the issue persists, [order an AC Inlet Service Kit \[12391.C\]](#).
3. If the on/off switch is glowing, push the circuit breaker next to the power switch [\[12391.D\]](#).
4. If the issue persists, unplug the power cord from both the outlet and your treadmill. Wait 5 minutes before proceeding. Use a Phillips head screwdriver to remove the motor and motor control board (MCB) covers. Refer to the "Replace the Motor Control Board Cover" section of the [service manual](#). Plug your treadmill back into power and watch the MCB for lights (**reference 1**).

(Reference 1)

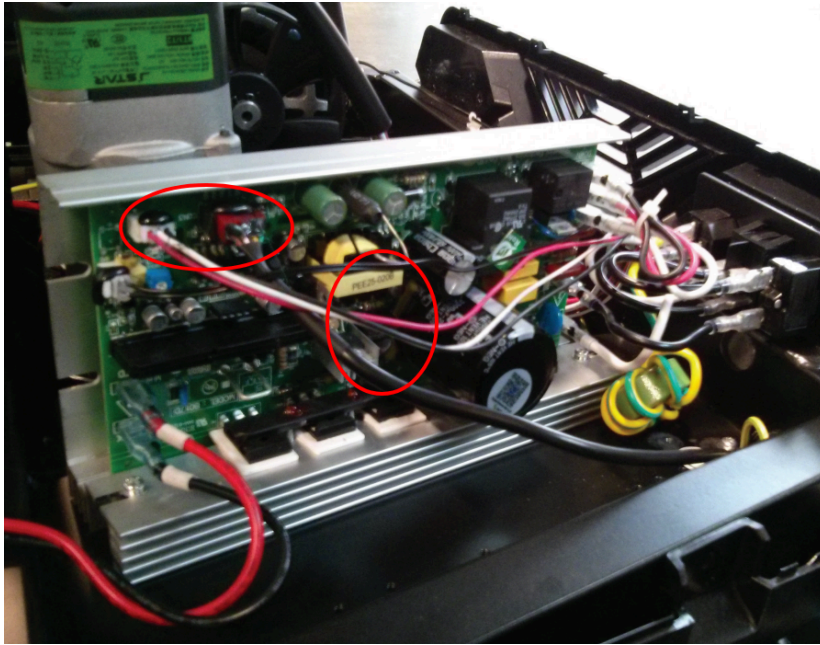

The position of lights on the MCB has changed several times during production. The most common location of lights are circled in red but they may be located elsewhere on the MCB if you have a different model MCB.

5. If no lights are seen on the MCB, push the circuit breaker to ensure it is not tripped [\[12391.E\]](#). Refer to the "Replace the Power Inlet" section of the [service manual](#) to ensure all wiring is securely connected and oriented properly. If the issue persists after checking the wiring, [order an AC Inlet Service Kit \[12391.F\]](#).
6. If the MCB does light up, check the input/output cables located at the top and bottom of the right upright ([reference 2](#)). If needed, use a 6mm Allen wrench to remove the console/handlebars to access the cables. Unplug each cable and inspect for damage. Securely reconnect undamaged cables, making sure that they are oriented in the proper direction [\[12391.G\]](#). If any cables are damaged, [order an MCB to Console Cable \[12391.H\]](#).

(Reference 2)

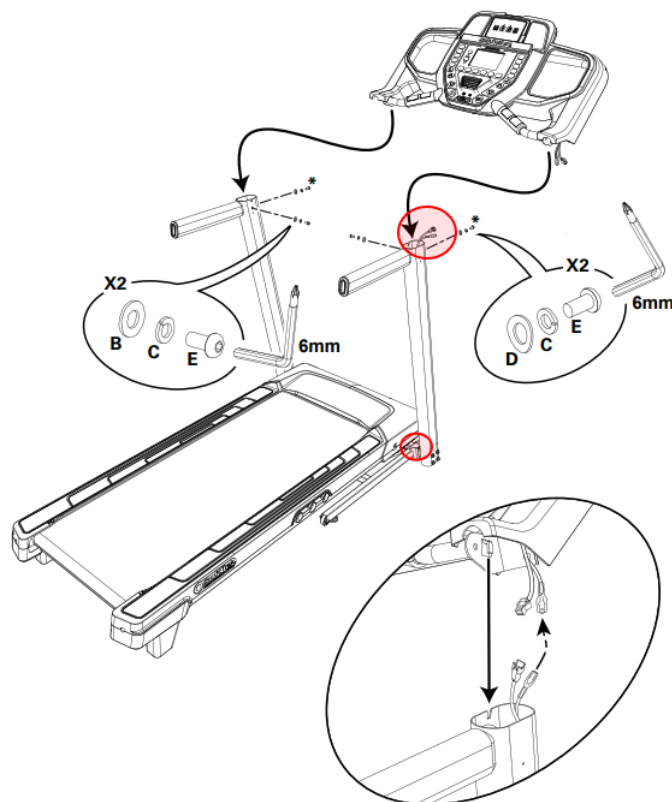

The cable connections to check are circled in red.

7. If the issue persists, [order a Console \[12391.I\]](#).

Need to order replacement parts?

1 Customer Care Contact Information

Please contact Customer Care at **1-800-605-3369** for additional help or to order replacement parts. Some replacement parts may also be available for purchase [online here](#). A list of part numbers referenced within this guide can be located at the bottom of this page.

Customer Care - Hours of Operation:

Monday - Friday 6:00am - 5:00pm PST

The replacement part will be provided to you at no cost assuming your machine meets the warranty eligibility requirements. A Customer Care Agent will be able to assess your current warranty eligibility and provide you with your options.

Please note that if you did not purchase your machine directly from BowFlex, Schwinn, or Nautilus, we will need a copy of your purchase receipt in order to register your machine for warranty.

2 Parts Reference Table

<i>Part Description</i>	<i>Part SKU</i>
AC Inlet Service Kit	8023383
Console	8020609
MCB to Console Cable	8023382
Power Cord	8005317

3 EAF Policy

EAF - Issues requiring Special Handling

ATTENTION: If the customer complains of any of the following, transfer the call to a Senior Rep in the **CS ESCALATION** queue.

- **NOTE THE CUSTOMER FILE:** "Transferred customer to Senior Rep/Sup due to escalated issue."

NOTE: This process is **ONLY** for Treadmills and TreadClimbers.

NOTE: This does not apply to second-hand purchases or unsupported products. The customer record must have a valid POP and serial number.

***Visible Smoke coming from machine:**

- Be sure to confirm specific color of smoke (blue, black, or white).
- NOTE: If complaint is a hot/smoky odor/smell, proceed with troubleshooting.

***Sparks or flames coming from their machine outside of the drive motor**

- (sparks from the brushes inside the drive motor are normal)

***Machine accelerates quickly (runs away) without user input/keypress**

***Belt moves without safety key in place**

***Strong Continuous Electric shock from machine frame** (beyond normal static shock, which is a single defined event and builds up prior to discharge)

***Belt stops suddenly without an error code, without user input, or the safety key being pulled.** Console remains on or working.

4 Contact Tech Team / Advanced Troubleshooting (TM/TC)

If the issue was not resolved in the steps listed, contact the Tech Team or send an Advanced Troubleshooting case.

Submit a Case with case type **Advanced Troubleshooting**

Use these procedures as needed to gather more information to create the case:

Results Series Treadmills Procedures

Treadmill 7 Procedures

Treadmill 10 Procedures

Treadmill 22 Procedures

MY14/17 Treadmill Procedures