

**Table of Contents**

1	Important Safety Instructions	2
1	Safety Warning Labels and Serial Number	3
1	Specifications	4
1	Grounding Instructions	5
1	Emergency Stop Procedure	6
1	Moving and Storing the Machine	7
1	Unfolding the Machine	9
1	Leveling the Machine	10
1	Treadmill Belt (break in period)	10
1	Connectivity	11
1	Maintenance	12
1	Cleaning	12
1	Adjusting the Belt Tension	13
1	Aligning the Walking Belt	13
1	Lubricating the Walking Belt	13
1	Maintenance Parts	15
1	Troubleshooting	17
1	Electrical Wiring Diagram	28
1	Replacement Procedure Skill Level	29
	Mechanical / Modification Procedures	
2	Adjust the Walking Belt	30
	Part Replacement	
3	Replace the Bottom Motor Cover	32
4	Replace the Console Assembly	37
5	Replace the Deck Suspension	40
6	Replace the Deck Wheel	43
7	Replace the Drive Belt	47
8	Replace the Front Roller	55
9	Replace the Incline Motor Assembly	63
10	Replace the I/O Cable	69
11	Replace the Lift Shock	75
12	Replace the Motor	79
13	Replace the Motor Control Board (MCB)	88
14	Replace the Motor Cover	93
15	Replace the Power Inlet	96
16	Replace the Rear Roller	101
17	Replace the Rear Roller Cover	105
18	Replace the Right Upright	108
19	Replace the Rocker Switch (On/Off)	114
20	Replace the Side Rail	119
21	Replace the Speed Sensor Assembly	123
22	Replace the Transport Wheel	128
23	Replace the Walking Belt	131
24	Replace the Walking Deck	140

**NOTICE:** This document provides important safety instructions, adjustments, and general troubleshooting information for the maintenance of the Schwinn™ 810 / 510T machine.

If you need assistance, please contact Customer Service (if purchased in US/Canada) or your local distributor (if purchased outside US/Canada). To find your local distributor, go to: [www.nautilusinternational.com](http://www.nautilusinternational.com)

 This icon means a potentially hazardous situation which, if not avoided, could result in death or serious injury. Read and understand all Warnings on this machine.

Nautilus, Inc., [www.NautilusInc.com](http://www.NautilusInc.com), 5415 Centerpoint Parkway, Groveport, OH 43125 U.S.A. - Customer Service: North America (800) 605-3369, [csnls@nautilus.com](mailto:csnls@nautilus.com) | outside U.S. [www.nautilusinternational.com](http://www.nautilusinternational.com) | Printed in China | © 2019 Nautilus, Inc. | Schwinn and the Schwinn logo are trademarks owned or licensed by Nautilus, Inc., registered or otherwise protected by common law in the United States and other nations. The Bluetooth® word mark and logos are registered trademarks owned by Bluetooth SIG, Inc., and any use of such marks by Nautilus, Inc. is under license. | **ORIGINAL DOCUMENT - ENGLISH VERSION ONLY**

### **Important Safety Instructions - Before servicing or using this equipment, obey the following warnings:**

 This icon means a potentially hazardous situation which, if not avoided, could result in death or serious injury. Read and understand all Warnings on this machine.

 **DANGER** To reduce the risk of electrical shock or unsupervised usage of the equipment, always unplug the power cord from the wall outlet and wait 5 minutes before cleaning, maintaining or repairing this machine. Place the power cord in a secure location.

- Read and understand the Part Replacement Procedure before working on the machine. Failure to obey the instructions and safety warnings could cause injury to the service technician or bystanders.
- Keep bystanders, children and pets away from the product being serviced at all times.
- Make sure that the repair is done in an appropriate work space away from foot traffic and exposure to bystanders.
- Disconnect all power and allow to sit for 5 minutes before you service this machine.
- Some components of the equipment can be heavy or awkward. Enlist the service of a second person when you do maintenance steps involving these components. Do not try to do heavy or awkward steps on your own.
- If replacement parts are necessary, use only genuine Nautilus replacement parts and hardware. Failure to use genuine replacement parts can cause a risk to users, keep the machine from operating correctly and will void the warranty.
- Be sure that all warning stickers and instructional placards applied to the product stay present and in good condition when doing maintenance or replacing components. If at any time the Warning labels become loose, unreadable or dislodged, replace the labels. If purchased in US/Canada, contact Customer Service for replacement labels. If purchased outside US/Canada, contact your local distributor for them.
- Do not try to change the design or functionality of the machine being serviced as this can adversely effect user safety and will void the warranty.
- Do not use the machine until all shrouds, instructions, warning labels and correct functionality have been verified and tested for correct performance.

• **SAVE THESE INSTRUCTIONS.**

# SAFETY WARNING LABELS AND SERIAL NUMBER



## CAUTION

Risk of Injury to Persons - To Avoid injury, use extreme caution when stepping onto or off of a moving belt. Read instruction manual before using.

## WARNING!

- Injury or death is possible if caution is not used while using this machine.
- Keep children and pets away.
- Read and follow all warnings on this machine.
- Refer to the Owner's Manual for additional warnings and safety information.
- The heart rate displayed is an approximation and should be used for reference only.
- Not intended for use by anyone under 14 years of age.
- The maximum user weight for this machine is 275 lbs (125 kg).
- For Consumer Use Only.
- Consult a physician prior to using any exercise equipment.
- REMOVE SAFETY KEY WHEN NOT IN USE, AND STORE OUT OF REACH OF CHILDREN.

(The label on the machine is available in English and French Canadian only.)

## WARNING!

Keep young children away from this machine at all times. Contact with the moving surface may result in severe friction burns.

(This label is only available on the 510T machine in English and Chinese.)

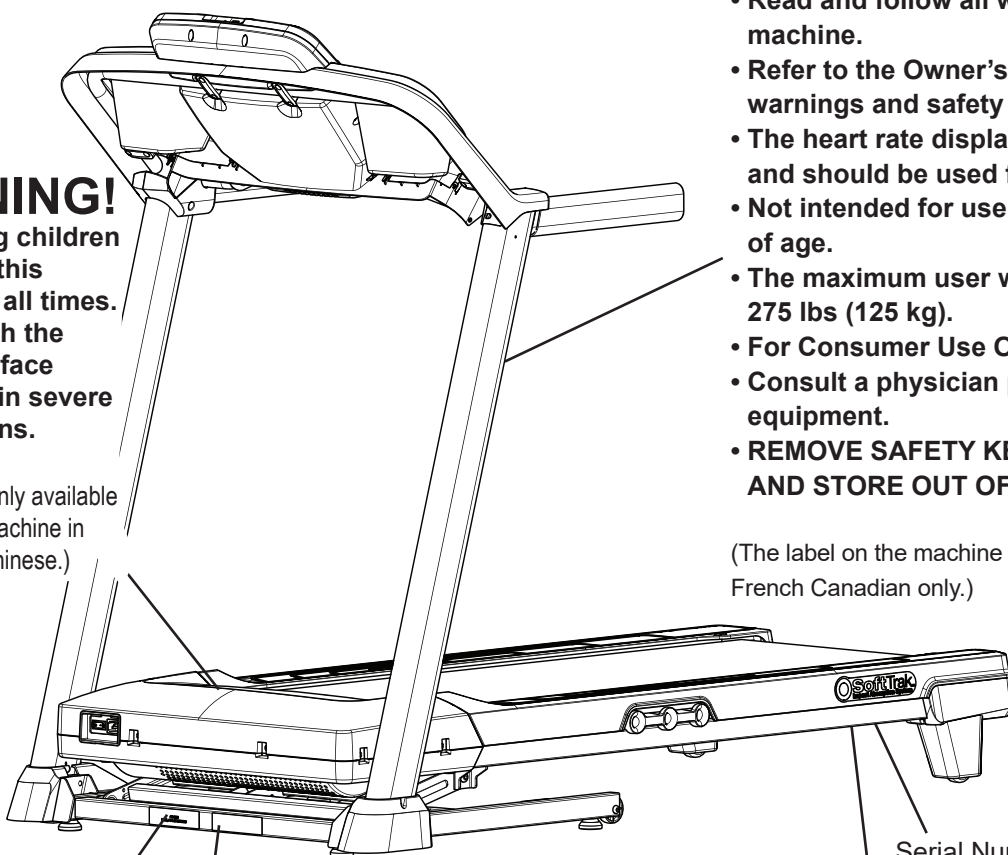

Serial Number

Product Specification

## WARNING!

### HAZARDOUS VOLTAGE.

- Contact may cause electrical shock or burn.
- Turn off and lock out power before servicing.

(These labels are in English and French Canadian on the 810 machine, and English, French Canadian and Chinese on the 510T machine.)



## WARNING!

- Moving parts can crush and cut.
- Keep guards in place.
- Lock out power before servicing.



# SPECIFICATIONS

## Power Requirements: 120V

Operational Voltage: 120V AC, 60Hz  
 Operating Current: 14 A

## 220V

220V - 240V AC, 50/60Hz  
 8 A

## Maximum User Weight:

125 kg (275 lbs)

## Total Surface Area (footprint) of equipment:

15,848 cm<sup>2</sup>

## Maximum Inclined Deck Height:

40 cm (15.8 inches)

## Machine Weight:

70.3 kg (155 lbs)

**Sound Emission:** Less than 70 db average without load. Noise emission under load is higher than without load.

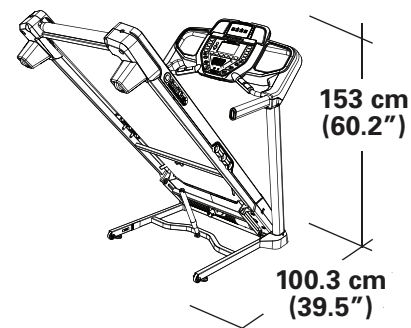
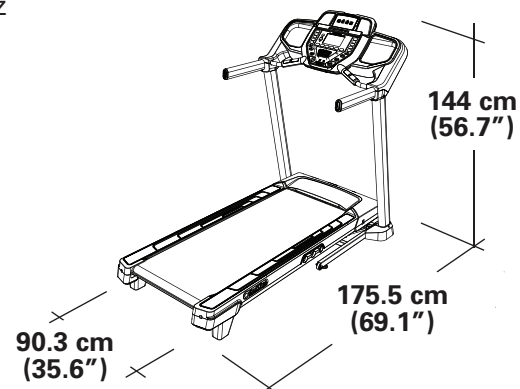

DO NOT dispose of this product as refuse. This product is to be recycled. For proper disposal of this product, please follow the prescribed methods at an approved waste center.

Select the area where you are going to set up and operate your machine. For safe operation, the location must be on a hard, level surface. Allow a minimum workout area of 190.3 cm x 376.2 cm (74.9" x 148.1"). Be sure that the workout space you are utilizing has adequate height clearance, taking into consideration the height of the user and the maximum incline of the machine.

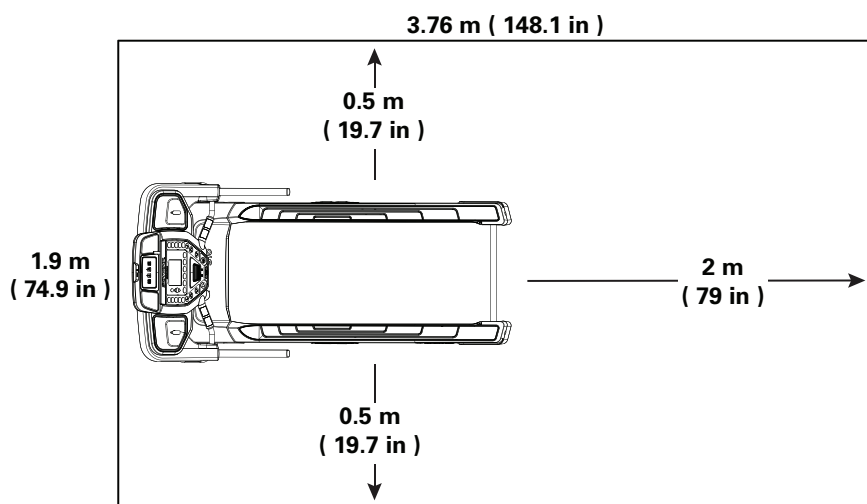

## Machine Mat

The Schwinn™ Machine Mat is an optional accessory that helps keep your workout area clear and adds a layer of protection to your floor. The rubber machine mat provides a non-slip, rubber surface which limits static discharge and reduces the possibility of display errors. If possible, put your Schwinn™ Machine Mat in your selected workout area before you begin assembly.

To order the optional machine mat, contact Customer Service (if purchased in US/Canada) or your local distributor (if purchased outside US/Canada).



## Grounding Instructions (for a 120V AC system )

This product must be grounded. If it should malfunction or break down, grounding provides a path of least resistance for electric current to reduce the risk of electric shock. This product is equipped with a cord having an equipment-grounding conductor and a grounding plug. The plug must be plugged into an appropriate outlet that is properly installed and grounded in accordance with all local codes and ordinances.

### **⚠ DANGER**

**Improper connection of the equipment-grounding conductor can result in a risk of electric shock. Check with a qualified electrician or serviceman if you are in doubt as to whether the product is properly grounded. Do not modify the plug provided with the product – if it will not fit the outlet, have a proper outlet installed by a qualified electrician.**

If you connect the machine to an outlet with GFI (ground fault interrupt) or AFI (arc fault interrupt), machine operation can cause the circuit to trip. This machine is for use on a nominal 120-V circuit, and has a grounding plug that looks like the plug illustrated below. A temporary adapter that looks like the adapter illustrated may be used to connect this plug to a 2-pole receptacle as shown if a properly grounded outlet is not available.

The temporary adapter should be used only until a properly grounded outlet can be installed by a qualified electrician. The tab for the grounding screw must be connected to a permanent ground such as a properly grounded outlet box cover. Whenever the adapter is used, it must be held in place by a metal screw.

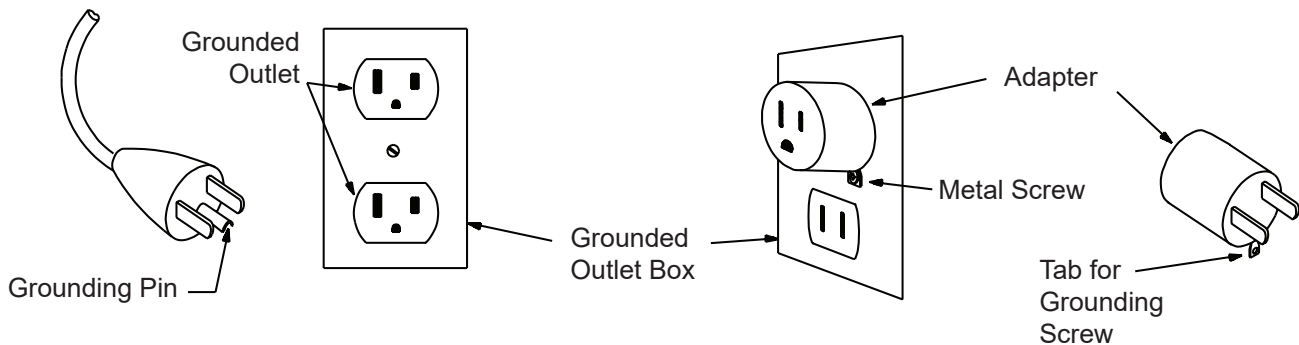

## Earthing Instructions (for a 220-240V AC system )

This product must be electrically earthed. If a malfunction occurs, correct earthing decreases the risk of electric shock. The power cord is equipped with an equipment-earthing conductor, and must be connected to an outlet that is properly installed and earthed.

### **⚠ DANGER**

**The electrical wiring must comply with all applicable local and provincial standards and requirements. Incorrect connection of the equipment-earthing conductor can result in a risk of electric shock. Consult a licensed electrician if you are not sure that the machine is correctly earthed. Do not change the plug on the machine – if it does not fit the outlet, have a correct outlet installed by a licensed electrician.**

If you connect the machine to an outlet with RCBO (Residual-Current circuit Breaker with Overload protection), machine operation can cause the circuit to trip. A Surge Protector Device is recommended to protect the machine.

**⚠ If a Surge Protector Device (SPD) is used with this machine, be sure that it matches the power rating of this equipment (220-240V AC). Do not connect other appliances or devices to the surge protector in combination with this machine.**

**Make sure that the product is connected to an outlet having the same configuration as the plug. Use the appropriate adapter supplied with this product.**

## Emergency Stop Procedure

The Treadmill machine is equipped with a Safety Key that can prevent serious injury, as well as prevent children from playing with and/or being injured on the machine. If the Safety Key is not correctly inserted into the Safety Key Port, the belt will not operate.

-  **Always attach the Safety Key Clip to your clothing during your workout.**
- When you use the machine, only remove the Safety Key in an emergency. When the key is removed while the machine is in operation, it will stop quickly, which could cause the loss of balance and possible injury.**
- For safe storage of the machine, and to prevent unsupervised operation of the machine, always remove the Safety Key and disconnect the power cord from the wall outlet and the AC input. Place the power cord in a secure location.**

The Console will display “ + SAFETY KEY ”, or add Safety Key, for a Safety Key fault. The Treadmill machine will not start a Workout, or will end and clear an active Workout, when the Safety Key is removed. Inspect the Safety Key and be sure it is connected to the Console correctly.

## FCC Compliance

-  **Changes or modifications to this unit not expressly approved by the party responsible for compliance could void the user's authority to operate the equipment.**

The machine and power supply comply with part 15 of the FCC rules. Operation is subject to the following two conditions: (1) This device may not cause harmful interference, and (2) this device must accept any interference received, including interference that may cause undesired operation.

**Note:** This machine and power supply have been tested and found to comply with the limits for a Class B digital device, pursuant to Part 15 of the FCC Rules. These limits are designed to provide reasonable protection against harmful interference in a residential installation. This equipment generates, uses and can radiate radio frequency energy and, if not installed and used in accordance with the instructions, may cause harmful interference to radio communications.

However, there is no guarantee that interference will not occur in a particular installation. If this equipment does cause harmful interference to radio or television reception, which can be determined by turning the equipment off and on, the user is encouraged to try to correct the interference by one or more of the following measures:

- Reorient or relocate the receiving antenna.
- Increase the separation between the equipment and receiver.
- Connect the equipment into an outlet on a circuit different from that to which the receiver is connected.
- Consult the dealer or an experienced radio/TV technician for help.

# ADJUSTMENTS

## Moving and Storing the Machine

**⚠** The machine can be moved by one or more persons. Use caution when you move the machine. The treadmill is heavy and can be awkward. Make sure that your own physical strength is capable of moving the machine. Use a second person if necessary.

1. Before the machine can be moved, inspect the Walking Deck to be sure the Incline setting is at “1”. If necessary, adjust the Incline setting to “1”.

**⚠** Be sure the area below the machine is clear before adjusting the incline of the Deck. Fully lower the incline of the Deck after each workout.

2. Remove the Safety Key and place it in a secure location.

**⚠** When this machine is not in operation, remove the Safety Key and keep out of the reach of children.

3. Make sure that the power switch is turned Off, and the power cord is disconnected.

4. You must fold the treadmill before you move it. Never move the treadmill if it is not folded.

**⚠** Never move the machine with the Walking Deck not folded. Rotating or moving parts can pinch, resulting in personal injury.

5. Make sure that there is safe clearance around, on and above your treadmill. Be sure to remove all water bottles, media devices, or loose items from the machine before moving it.

**⚠** Be sure there is adequate height clearance for the raised deck.

6. Using the support bar found below the rear of the walking belt, lift the walking deck fully upward and engage the hydraulic lift. Be sure that the hydraulic lift is correctly locked in place. You will hear an audible click when the hydraulic lift shifts into the locked position.

**⚠** Use proper safety precautions and lifting techniques. Bend your knees and elbows, keep your back straight and pull up equally with both arms. Straighten your legs to lift. Make sure that your own physical strength is capable of lifting the walking deck until it engages the locking mechanism. Use a second person if necessary.

**Do not use the walking belt or rear roller to lift the treadmill. These parts do not lock in place and can abruptly move. Injury to you or damage to the machine can occur.**

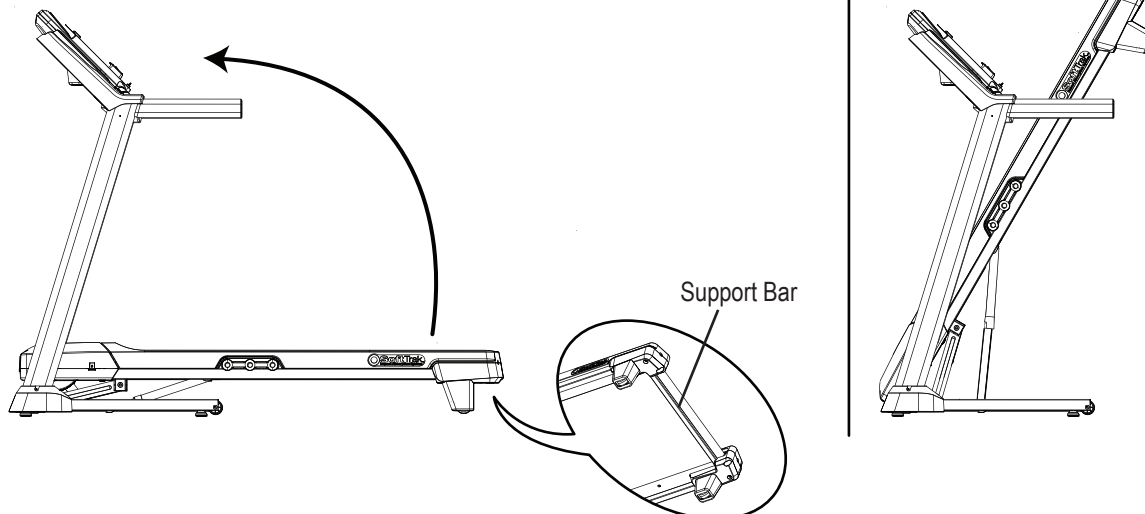

7. Make sure that the locking mechanism is engaged. Carefully pull back on the Walking Deck and make sure that it does not move. When you do this, keep clear of movement path in case the treadmill lock is not properly engaged.

**!** Do not lean against the treadmill when it is folded. Do not put items on it that could cause it to become unstable or fall.

**Do not connect the power cord or try to operate the treadmill in the folded position.**

8. Stand to one side of the treadmill. Place your front foot so it pins the Base Assembly. Grasping the Side Handrail, carefully pivot the treadmill rearward until it is balanced fully on the transport wheels. Be sure not to pivot the machine too far. Hold the treadmill in the balanced position.

**!** This step may require two persons on each side of the treadmill. The treadmill is heavy and can be awkward. Make sure that your own physical strength is capable of pivoting the machine.

**Always wear fully enclosed shoes when moving this machine. Do not move the machine with bare feet or only wearing socks.**

**Do not use the Console or lifted Walking Deck to pivot or move the treadmill. Injury to you or damage to the machine can occur.**

**Keep clear of the movement path of the lifted Walking Deck.**

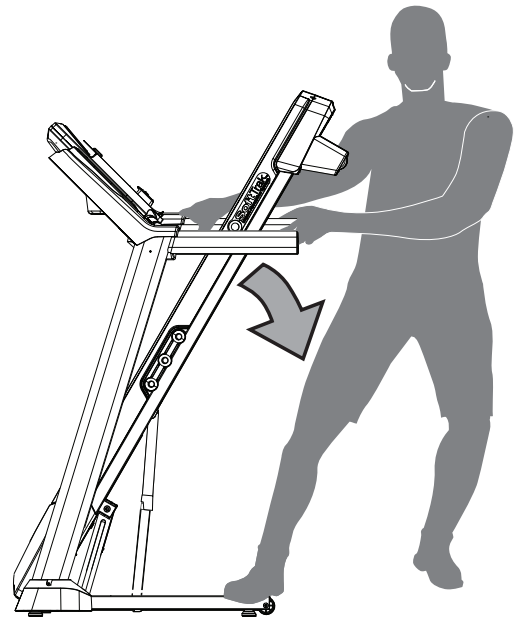

9. Grasping the Side Handrail and the front of the Upright, safely roll the treadmill to the desired location.

**!** The treadmill is heavy and can be awkward. Make sure that your own physical strength is capable of moving the machine.

**Place the machine on a clean, hard, level surface, free from unwanted material or other objects that may hamper your ability to move freely. A rubber mat should be used below the machine to prevent the release of static electricity and protect your flooring.**

**Do not put objects in the path of the walking deck when lowered.**

**NOTICE:** Move the machine carefully so that it does not hit other objects. This can damage the Console operation, the treadmill, or the area around the machine.

10. Safely lower the treadmill into the desired position. Be sure there is adequate space for the machine before lowering it.

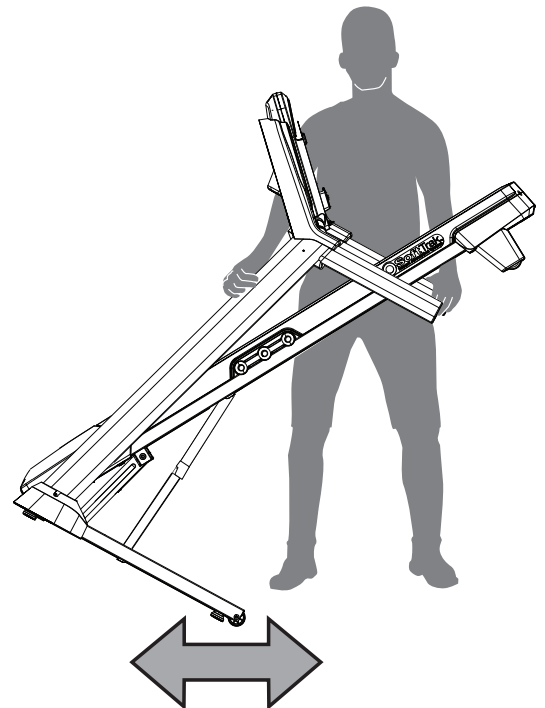

11. Prior to use, refer to the “Unfolding the Machine” procedure in this manual.

## Unfolding the Machine

1. Make sure there is sufficient space to lower the walking deck.

**⚠️ Keep a minimum clearance behind the machine of 79" (2 m) and 24" (0.6 m) on each side. This is the recommended safe distance for access, movement and emergency dismounts from the machine.**

Place the machine on a clean, hard, level surface, free from unwanted material or other objects that may hamper your ability to move freely with a sufficient clear workout area. A rubber mat below the machine is recommended to prevent electrostatic discharge and protect your floor.

**Be sure that the workout space you are utilizing has adequate height clearance, taking into consideration the height of the user and the maximum incline of the deck.**

2. Make sure there is no object on or around the treadmill to spill or cause blockage from the fully unfolded position.
3. Slightly push the walking deck forward toward the console. With your left foot lightly push the top part of the hydraulic lift forward until the locking tube releases and you can pull the walking deck away from the console. Hold up the rear of the walking deck, and move to the side of the machine.

**⚠️ Keep clear of the movement path of the walking deck.**

4. The hydraulic lift is set up to drop lightly. Hold onto the walking deck until approximately 2/3 of the movement down. Lower the weight with your legs. The walking deck can possibly drop quickly in the last part of the movement.

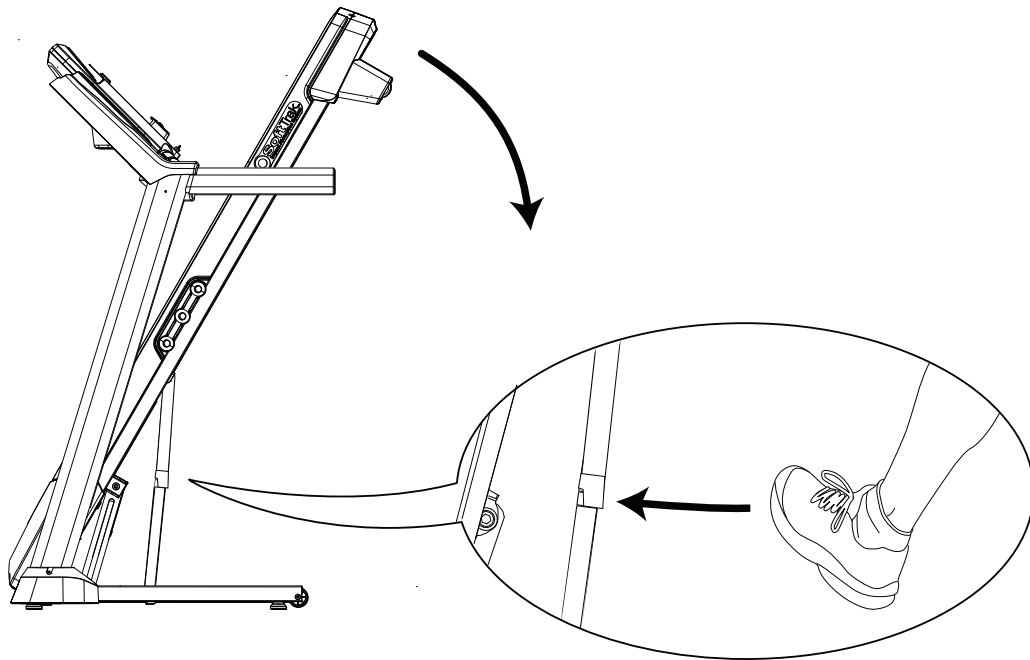

## Leveling the Machine

The machine needs to be leveled if your workout area is uneven. To adjust:

1. Place the machine in your workout area.
2. Adjust the levelers until they all contact the floor.

**⚠ Do not adjust the levelers to such a height that they detach or unscrew from the machine. Injury to you or damage to the machine can occur.**

3. Adjust until the machine is level.

Make sure the machine is level and stable before you exercise.

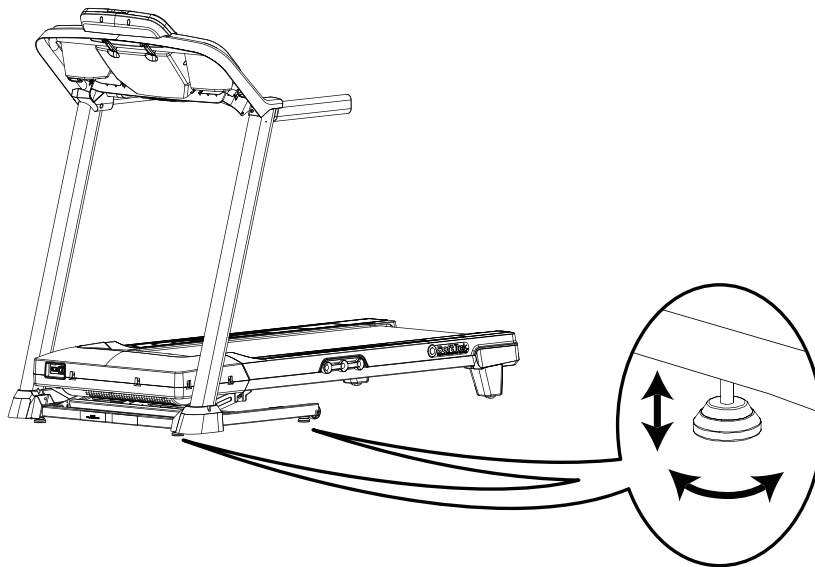

## Treadmill Belt

Your treadmill comes equipped with a durable, high quality walking belt designed to provide many hours of reliable service. The walking belt on a treadmill that has not been operated for a length of time, either in factory packaging or after assembly, can exhibit a “thumping” noise when started. This is due to the belt taking on the curve of the front and rear rollers. This is a common occurrence and does not indicate a problem with your machine. After the treadmill has been used for a short period of time the thumping noise will discontinue. The amount of time will vary depending on the temperature and humidity of the environment where the treadmill is placed.

## **CONNECTIVITY**

### **Workout with Other Fitness Apps**

This fitness machine has integrated Bluetooth® connectivity which allows it to work with a number of digital partners. For our latest list of supported partners, please visit: [www.nautilus.com/partners](http://www.nautilus.com/partners)

### **USB Charging**

Your machine is equipped with a USB Port to allow it to charge some devices. Simply attach a USB Cable (not included) to the USB Port, and attach your device to the other end of the USB Cable. The power supplied from the USB Port may not be enough to operate the Device and charge it at the same time.

**Note:** The USB Port is only for charging and unable to play audio from the speakers on the Console.

### **Speakers and Audio Cable**

To play audio through the speakers on your machine, attach the Audio Cable to your device and to the Audio Cable Port on the Console. With the Console turned on, you can play audio from your device through the speakers. Volume is controlled from your device.

**Note:** Though your machine is Bluetooth® enabled, it is unable to receive and play audio across a Bluetooth® connection.



## MAINTENANCE

Read all maintenance instructions fully before you start any repair work. In some conditions, an assistant is required to do the necessary tasks.

**!** Equipment must be regularly examined for damage and repairs. The owner is responsible to make sure that regular maintenance is done. Worn or damaged components must be repaired or replaced immediately. Only manufacturer supplied components can be used to maintain and repair the equipment.

If at any time the Warning labels become loose, unreadable or dislodged, replace the labels. If purchased in US/Canada, contact Customer Service for replacement labels. If purchased outside US/Canada, contact your local distributor for them.

### **! DANGER**

To reduce the risk of electrical shock or unsupervised usage of the equipment, always unplug the power cord from the wall outlet and the machine and wait 5 minutes before cleaning, maintaining or repairing the machine. Place the power cord in a secure location.

#### Daily:

Before each use, examine the exercise machine for loose, broken, damaged, or worn parts. Do not use if found in this condition. Repair or replace all parts at the first sign of wear or damage, except for the Walking Deck. The Walking Deck is designed for wear on both sides of it. If only one side of the Walking Deck is worn, a replacement Deck is not required. It is recommended that a qualified service technician is used to flip the Walking Deck. After each workout, use a damp cloth to wipe your machine and Console free of moisture.

**!** With the Walking Deck lowered, if an edge of the Walking Belt can be seen adjust it until the edge is not viewable.

**Note:** Avoid excessive moisture on the Console.

#### Weekly:

Check for smooth roller operation. Wipe the machine to remove dust, dirt, or grime.

**!** Do not remove the Motor Cover, as dangerous voltages and moving parts are present. The components are serviceable only by approved service personnel or by following service procedures supplied by Nautilus, Inc.

**Note:** Do not use petroleum based products.

#### Monthly or after 20 hours:

Make sure all bolts and screws are tight. Tighten as necessary.

#### Quarterly:

Or after 25 hours - Lubricate the walking belt with 100% silicone lubricant (not included with the machine).

**!** Silicone lubricant is not intended for human consumption. Keep out of reach of children. Store in a safe place.

**NOTICE:** Do not clean with a petroleum based solvent or an automotive cleaner. Be sure to keep the Console free of moisture.

## Cleaning

### **! DANGER**

To reduce the risk of electrical shock, always unplug the power cord and wait 5 minutes before cleaning, maintaining or repairing this machine.

Wipe the treadmill down after each use to keep the treadmill clean and dry. It may be necessary to use a mild detergent at times to remove all dirt and salt from the belt, painted parts and the display.

**NOTICE:** To prevent damage to the finish of the machine or Console, do not clean with a petroleum based solvent. Do not apply too much moisture to the Console.

### Adjusting the Belt Tension

If the walking belt starts to slip during use, it is necessary to adjust the tension. Your treadmill has tension bolts at the rear of the treadmill.

1. Before you adjust the belt tension, start the treadmill by pushing the START button.

**⚠ Be sure not to touch the walking belt or step on the power cord. Keep bystanders and children away from the product you are servicing at all times.**

2. Use a 6 mm hex key to turn the right and left belt adjustment bolts clockwise a 1/2 turn, first one bolt and then the other bolt until the belt does not slip.
3. After you adjust each side the 1/2 turn, do a test to see if the belt stopped slipping. If the belt still slips, do steps 2 and 3 again.

If you turn one side more than the other, the belt will move away from that side of the treadmill and may need realignment.

**NOTICE:** Too much tension on the belt causes unnecessary friction and wears the belt, motor and electronics.

4. Push PAUSE/STOP twice to stop the walking belt and end the Quick Start workout.

### Aligning the Walking Belt

The walking belt should be centered on your treadmill at all times. Running style and a non-level surface can cause the belt to move off center. Minor adjustments to the 2 bolts at the rear of the treadmill are necessary when the belt is off center.

1. Push the START button to start the walking belt.

**⚠ Be sure not to touch the walking belt or step on the power cord. Keep bystanders and children away from the product you are servicing at all times.**

2. Stand at the rear of the treadmill to see which direction the belt moves.
3. If the belt moves to the left, turn the left belt adjustment bolt 1/4 turn clockwise and the right belt adjustment bolt 1/4 turn counterclockwise.

If the belt moves to the right, turn the left adjustment bolt 1/4 turn counterclockwise and the right adjustment bolt 1/4 turn clockwise.

4. Monitor the path of the belt for approximately 2 minutes. Continue to adjust the bolts until the walking belt is centered.
5. Push PAUSE/STOP twice to stop the walking belt and end the Quick Start workout.

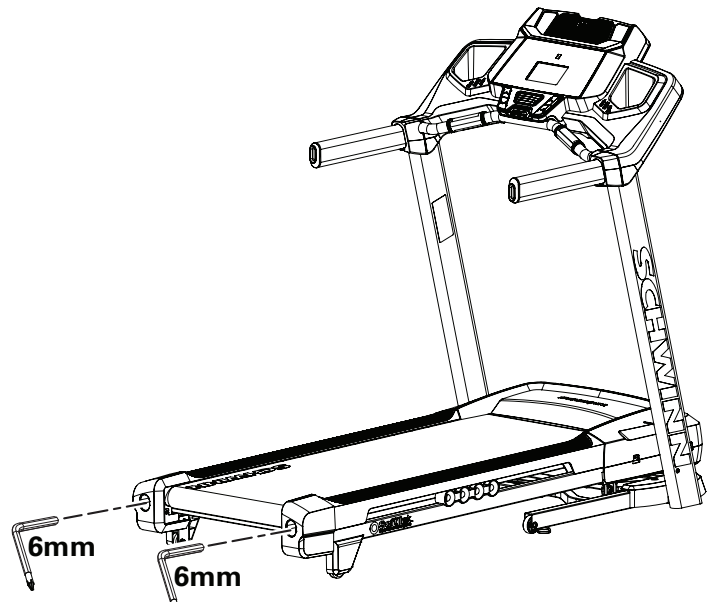

### Lubricating the Walking Belt

Your treadmill is equipped with a low maintenance deck and belt system. The Walking Belt is pre-lubricated. Belt friction can affect the function and life of the machine. Lubricate the belt every 3 months or every 25 hours of use, whichever comes first. Even if the treadmill is not in use, silicone will dissipate and the belt will dry out. For the best results, lubricate the deck periodically with a silicone lubricant using the following instructions:

1. Turn off the power to the machine with the power switch.
2. Unplug the treadmill fully from the wall outlet, and remove the power cord from the machine.

## **⚠ DANGER**

**To reduce the risk of electrical shock, always unplug the power cord and wait 5 minutes before cleaning, maintaining or repairing this machine. Place the power cord in a secure location.**

3. Inspect the surface material below the Treadmill. If the surface material is difficult to clean or could be damaged by silicone lubricant, place absorbent material (such as cardboard or newspaper) below the length of the Walking Deck.
4. Apply a few drops of the lubricant on the deck below the belt. Carefully lift the belt and apply a few drops of the lubricant the entire width of the belt. A very thin layer of silicone lubricant on the entire deck below the belt is desired.

**NOTICE:** Always use a 100% pure silicone lubricant. Do not use a degreaser like WD-40® as this could seriously impact performance. We can recommend that you use the following:

- 100% pure silicone, available at most hardware and auto parts stores.
- Lube-N-Walk® Treadmill Lubrication Kit, available from your local specialty fitness dealer or Nautilus, Inc.

**⚠ Silicone lubricant is not intended for human consumption. Keep out of reach of children. Store in a safe place.**

5. Manually rotate the belt 1/2 of the length of the belt and apply lubricant again.

**⚠ If you used spray lubricant, wait 5 minutes before turning on power to the machine to allow the aerosol to dissipate.**

6. Connect the power cord back into the machine and then into the wall outlet.
7. Turn on the power to the machine with the power switch.
8. Stay to one side of your machine and start the belt at the slowest speed. Let the belt operate for approximately 15 seconds.

**⚠ Be sure not to touch the walking belt or step on the power cord. Keep bystanders and children away from the product you are servicing at all times.**

9. Switch off your machine.
10. Take care to clean up any excess lubricant from the deck.

**⚠ To decrease the possibility of slipping, be sure the deck area is free from grease or oil. Clean off any excess oil from the machine surfaces.**

As you use your fitness machine, the Console will show “LUBRICATE BELT” followed by “REVIEW USER MANUAL” at set times. This is only a reminder and should be added to your inspection schedule. Only apply lubricant as necessary. Push any button to accept the reminder.

## Maintenance Parts

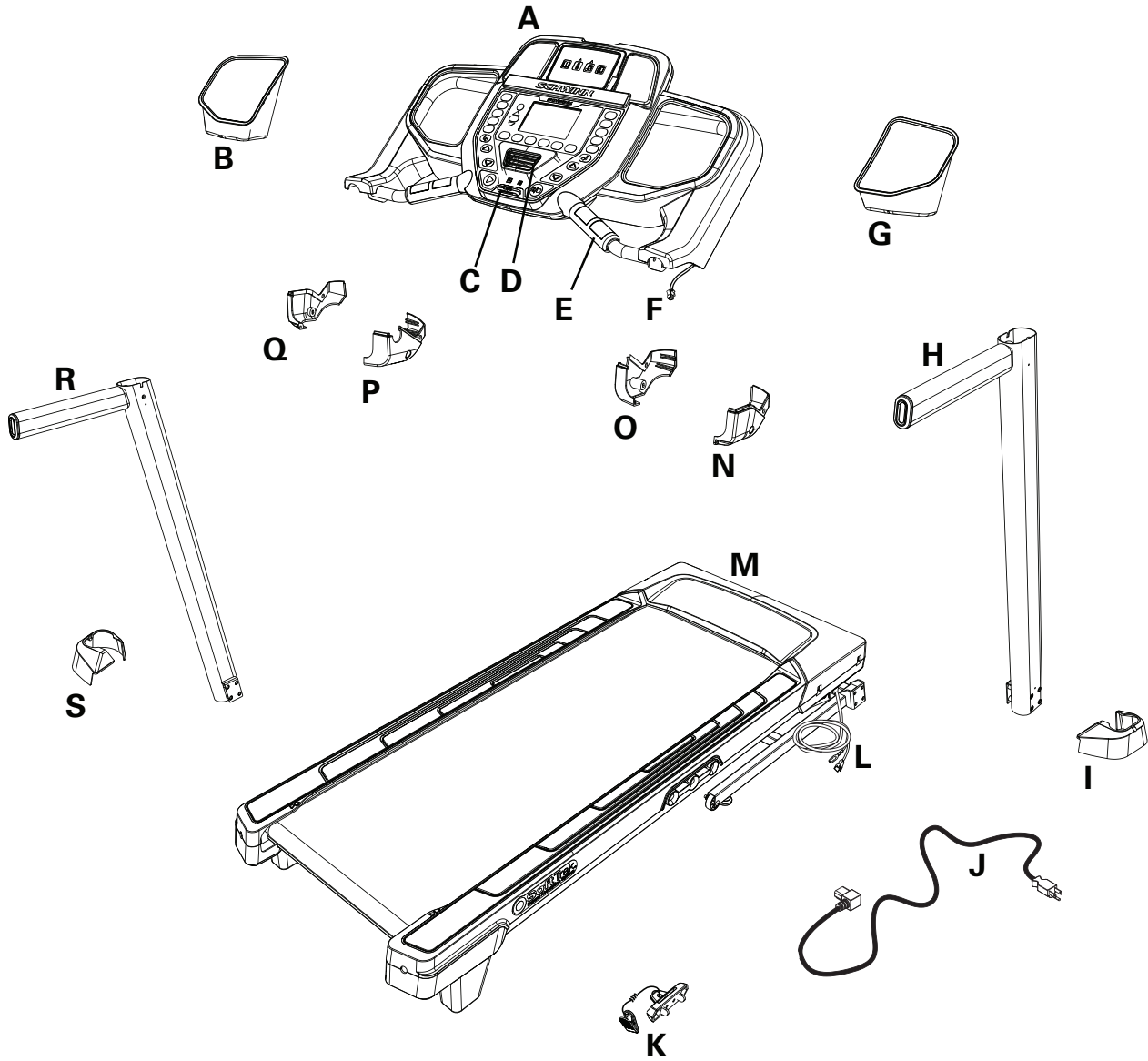

A	Console Assembly	H	Upright, Right	O	Handlebar Shroud, Right Inner
B	Tray, Left	I	Base Shroud, Right	P	Handlebar Shroud, Left Inner
C	Safety Key Port	J	Power Cord	Q	Handlebar Shroud, Left Outer
D	Fan	K	Safety Key	R	Upright, Left
E	Contact Heart Rate Sensor	L	Base Cable	S	Base Shroud, Left
F	Console Cable	M	Base Assembly		
G	Tray, Right	N	Handlebar Shroud, Right Outer		

## Maintenance Parts ( Frame )

Front

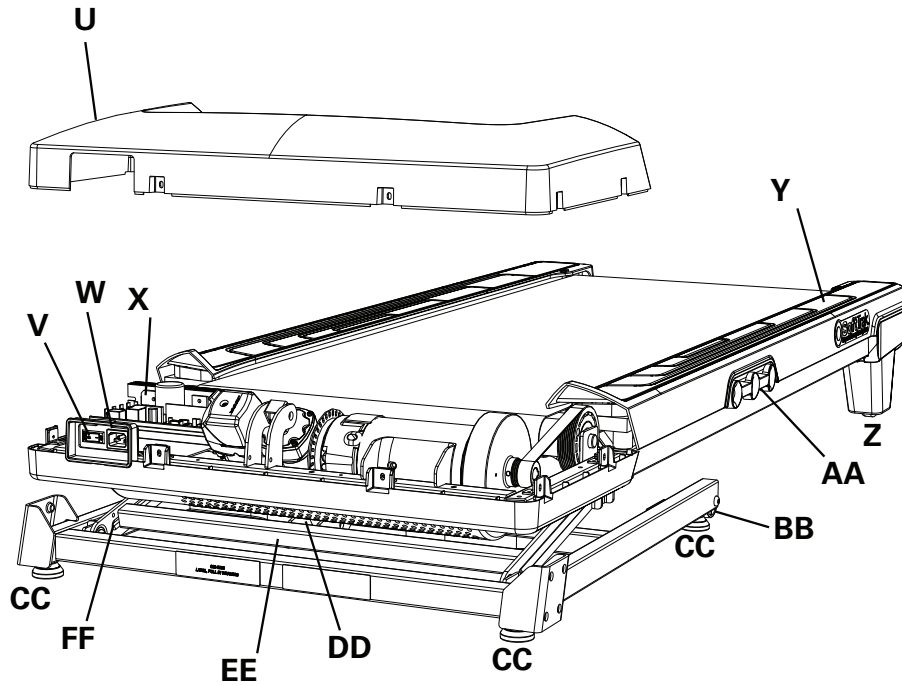

Back

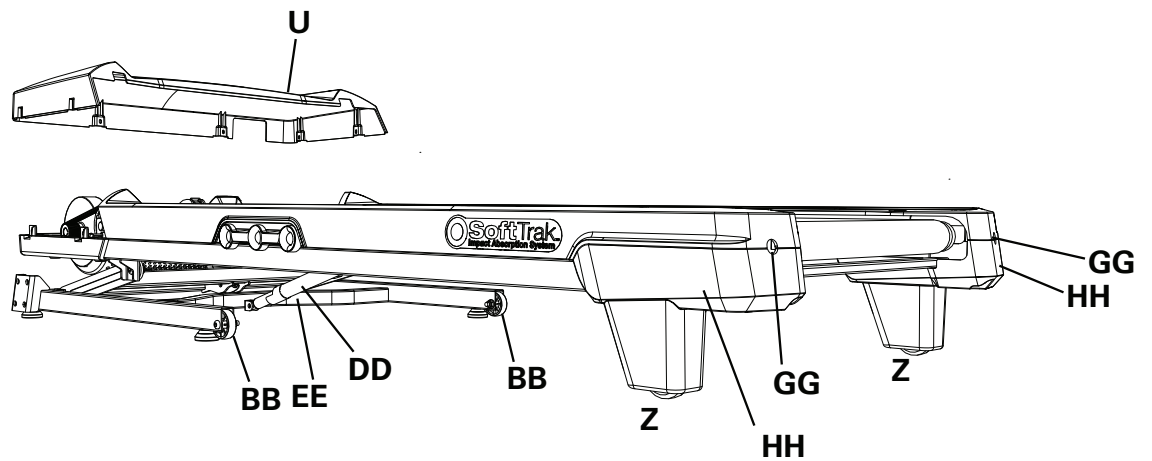

U	Motor Cover	Z	Base Support	EE	Incline Adjuster
V	Power Switch	AA	Deck Cushioners	FF	Pivot Assembly
W	Power Input	BB	Transport Wheel	GG	Belt Tensioner
X	Motor Control Board	CC	Leveler	HH	Rear Roller Cover
Y	Side Foot Support Rails	DD	Lifting Cylinder		

## Service Mode Procedures

### PROCEDURE 1: CALIBRATE MCB:

1. Stand next to the machine where the Console can easily be reached.

 **Be sure the area around the Treadmill is clear of all bystanders, children and pets. Be sure there is nothing on or under the Walking Belt, or near the Treadmill.**

2. Push and hold down the Pause/Stop and Enter buttons until the machine enters engineering mode

3. Push the Start button 8 times.

4. The calibration procedure will begin by automatically moving the Walking Belt and adjusting the incline of the Walking Deck for about a minute. Then the console will flash and beep.

 **Be sure not to touch or allow anyone else to touch the machine while calibration is occurring.**

5. Procedure is now complete.

Unit will not power on, or power is on but Console does not light up

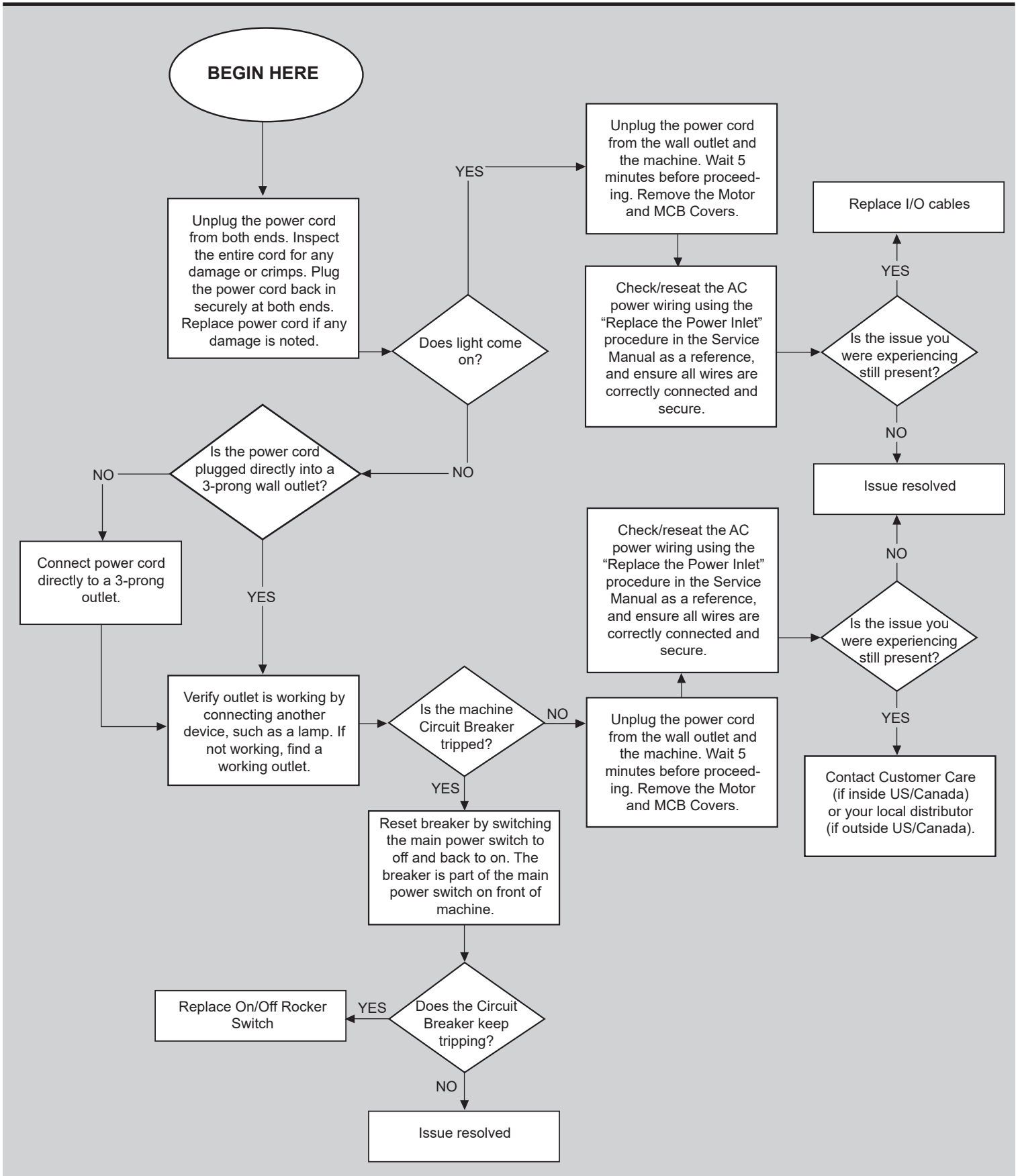



# Noise Issues

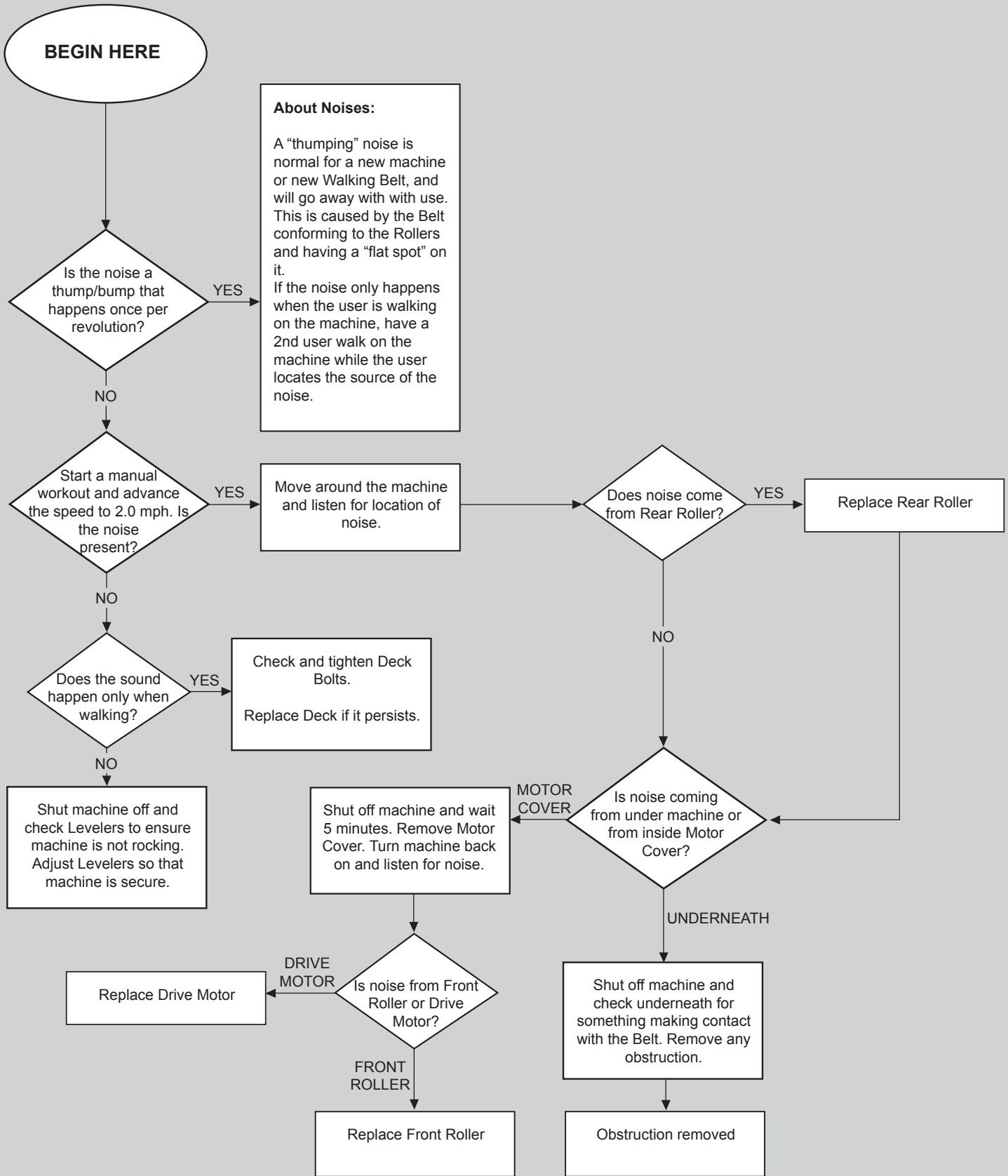

# Machine Shuts Off or Belt Stops During Workout

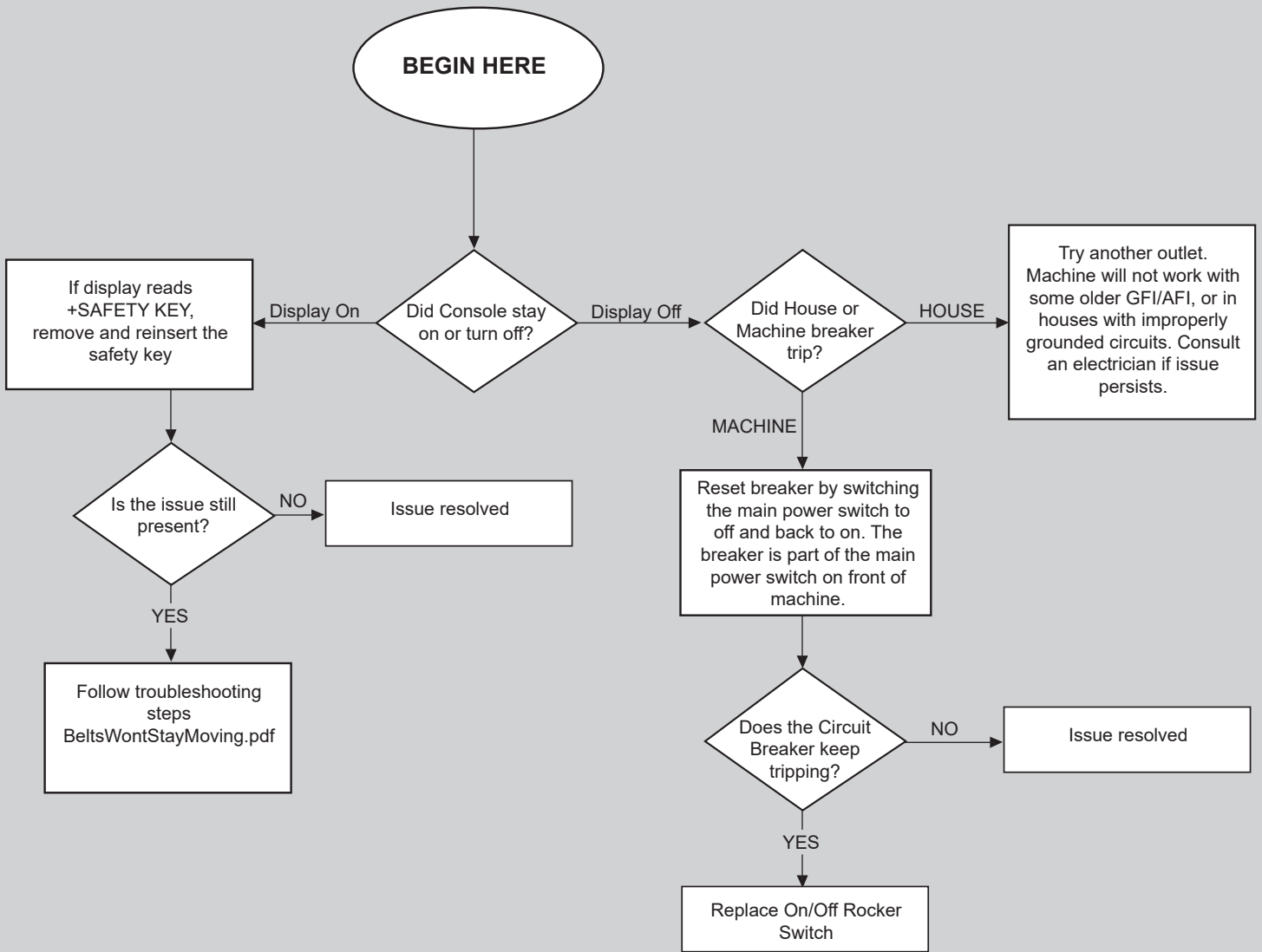

## Incline Issues

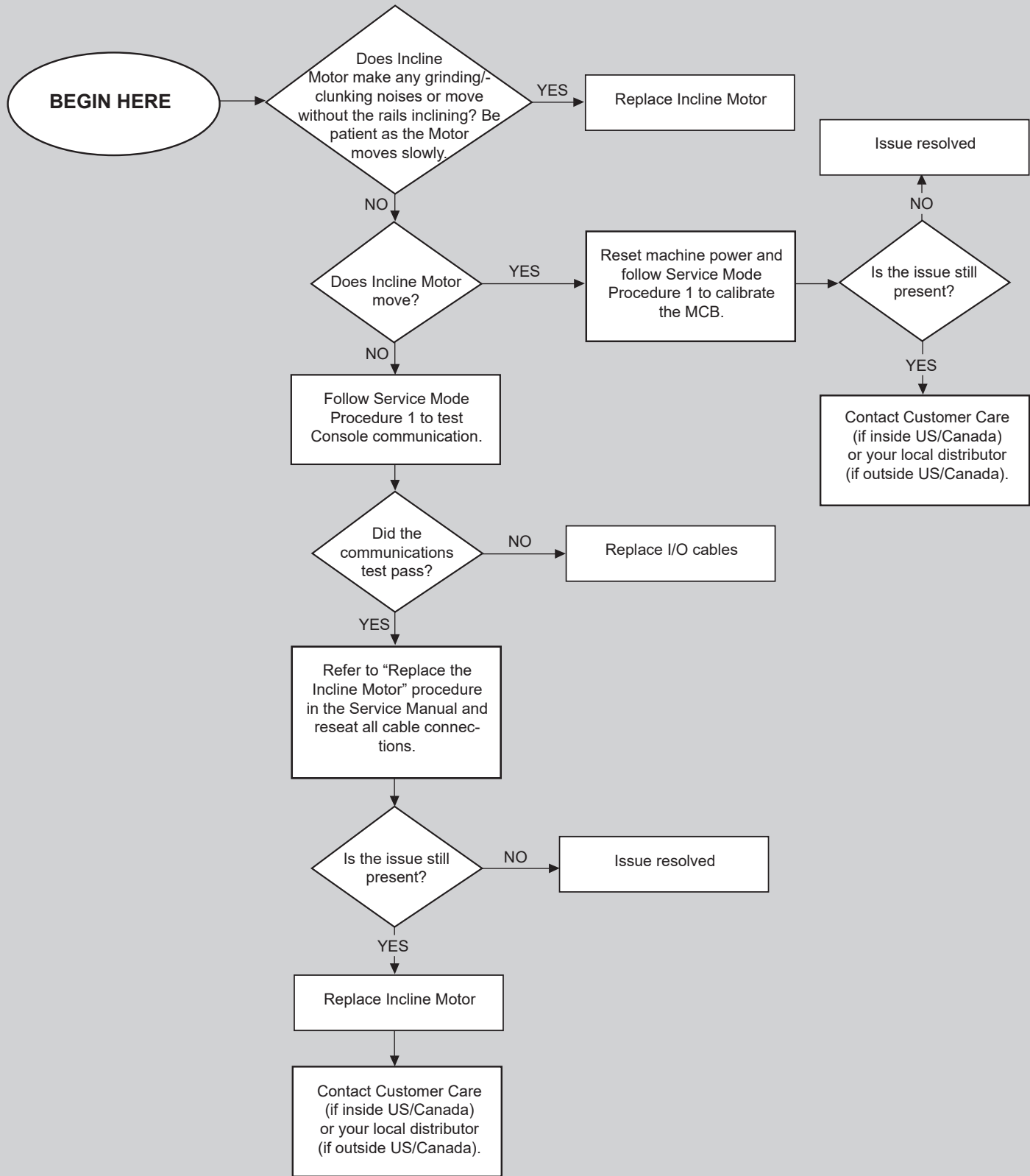

## Heart Rate Issues

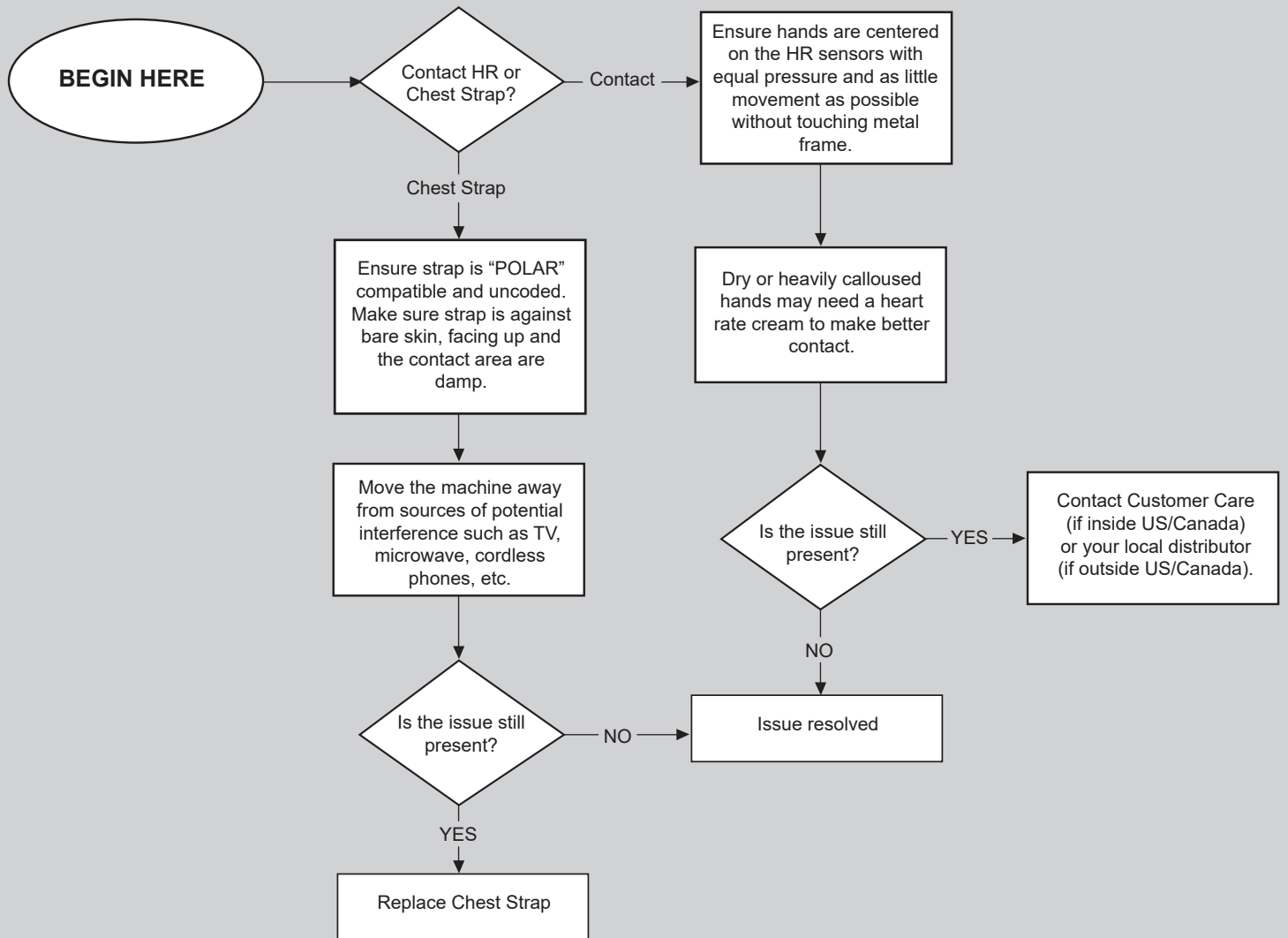

**BEGIN HERE:**

If Console will not light up, follow "Unit will not power on" Troubleshooting Procedure.  
If the units of measure are incorrect, follow the Owner's Manual instructions to correct the setting before beginning these steps.

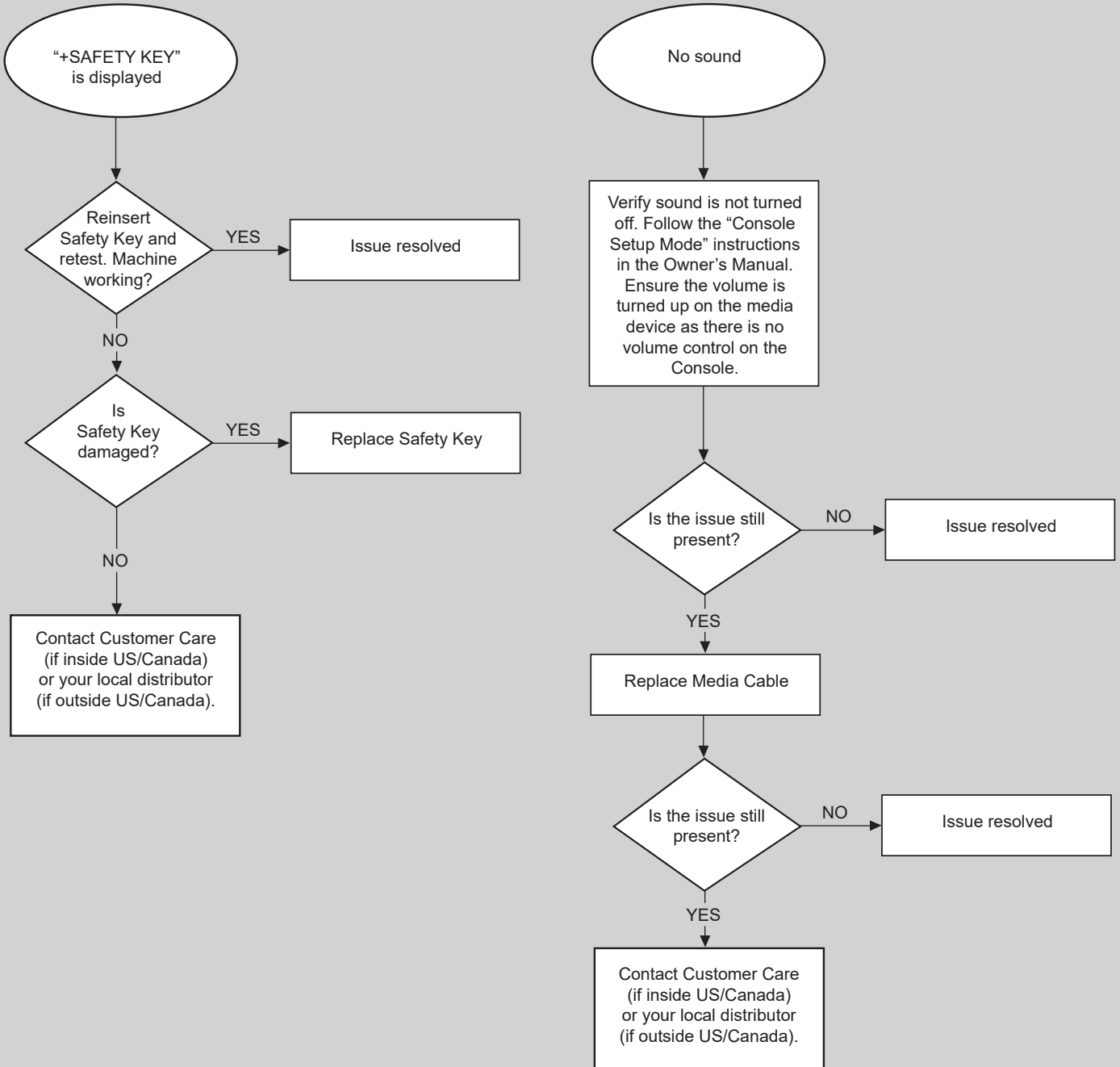

**BEGIN HERE:** If Console will not light up, follow "Unit will not power on" Troubleshooting Procedure.  
If the units of measure are incorrect, follow the Owner's Manual instructions to correct the setting before beginning these steps.

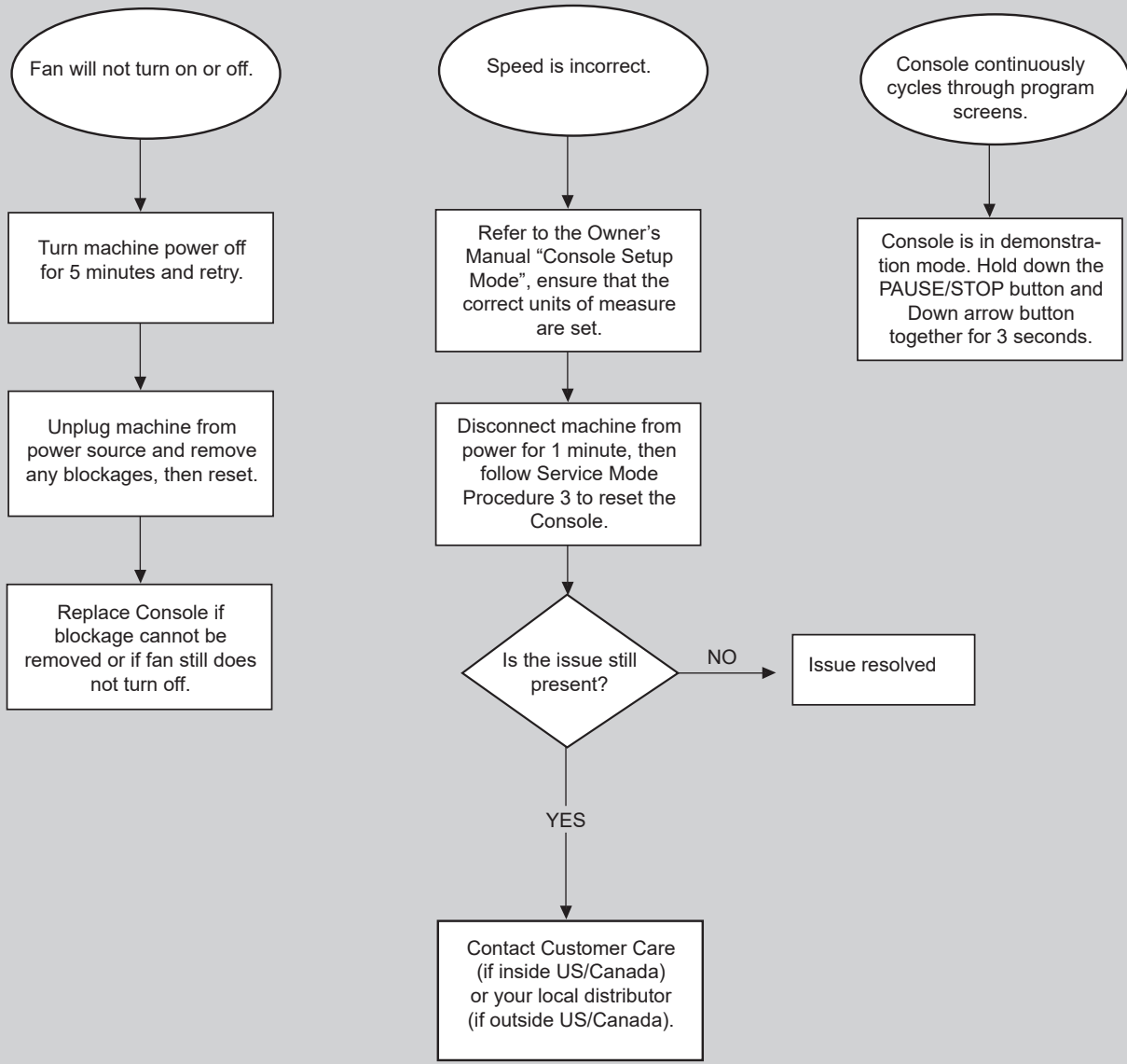

## Buttons Do Not Respond

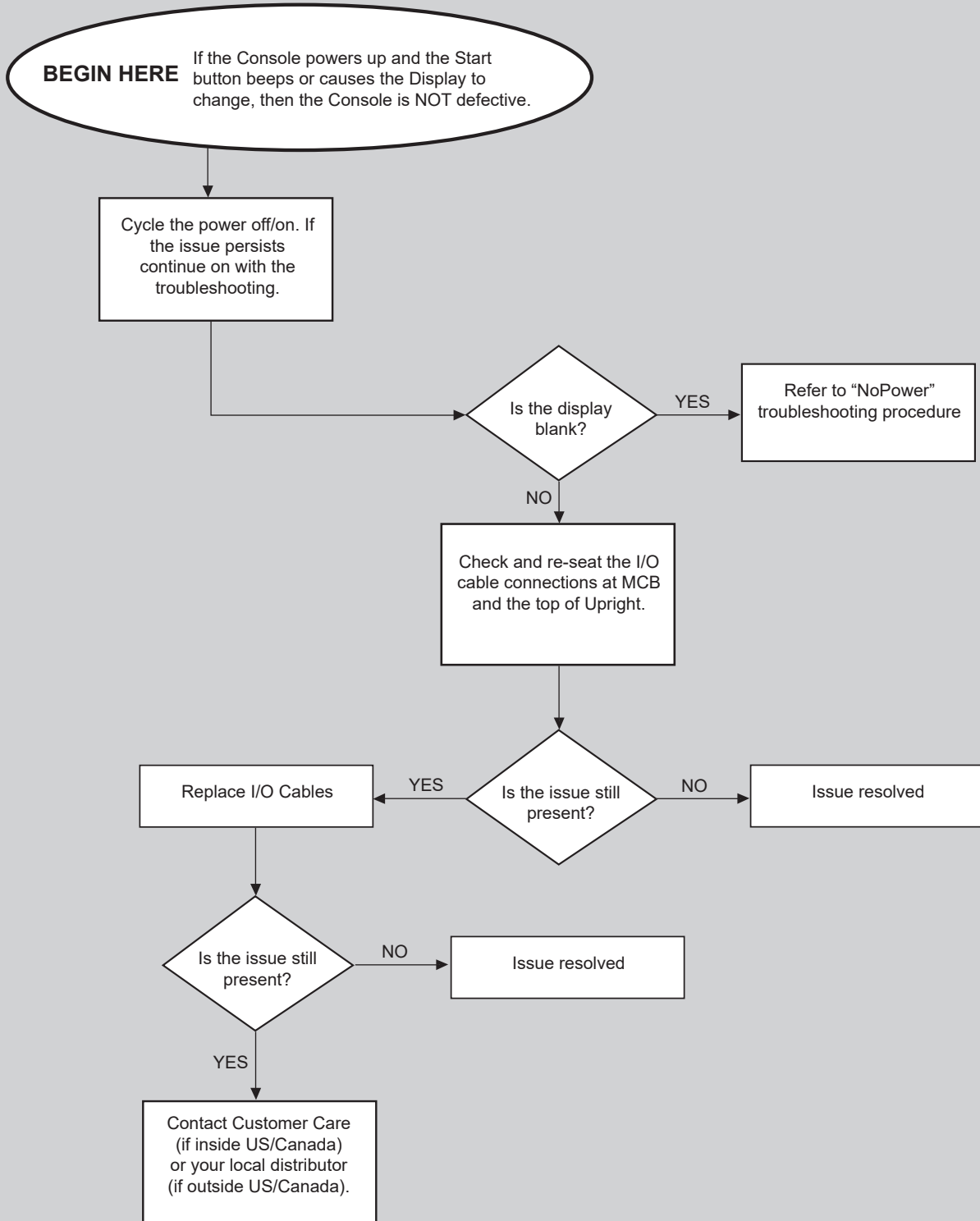



## Walking Belt stops while in use, moves briefly, or does not move at all (Console lights up)

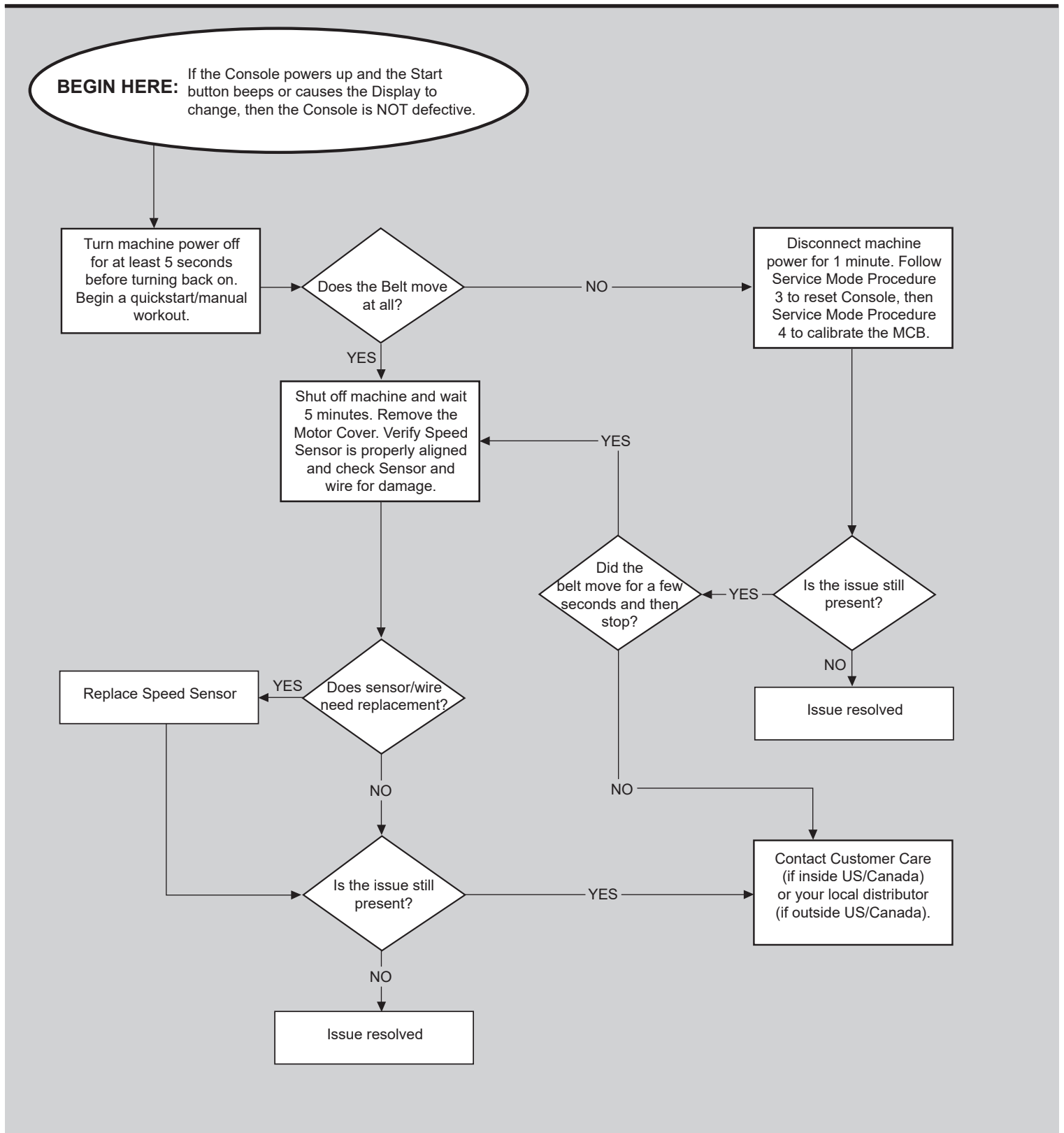

## Belt Alignment / Slipping / Hesitation

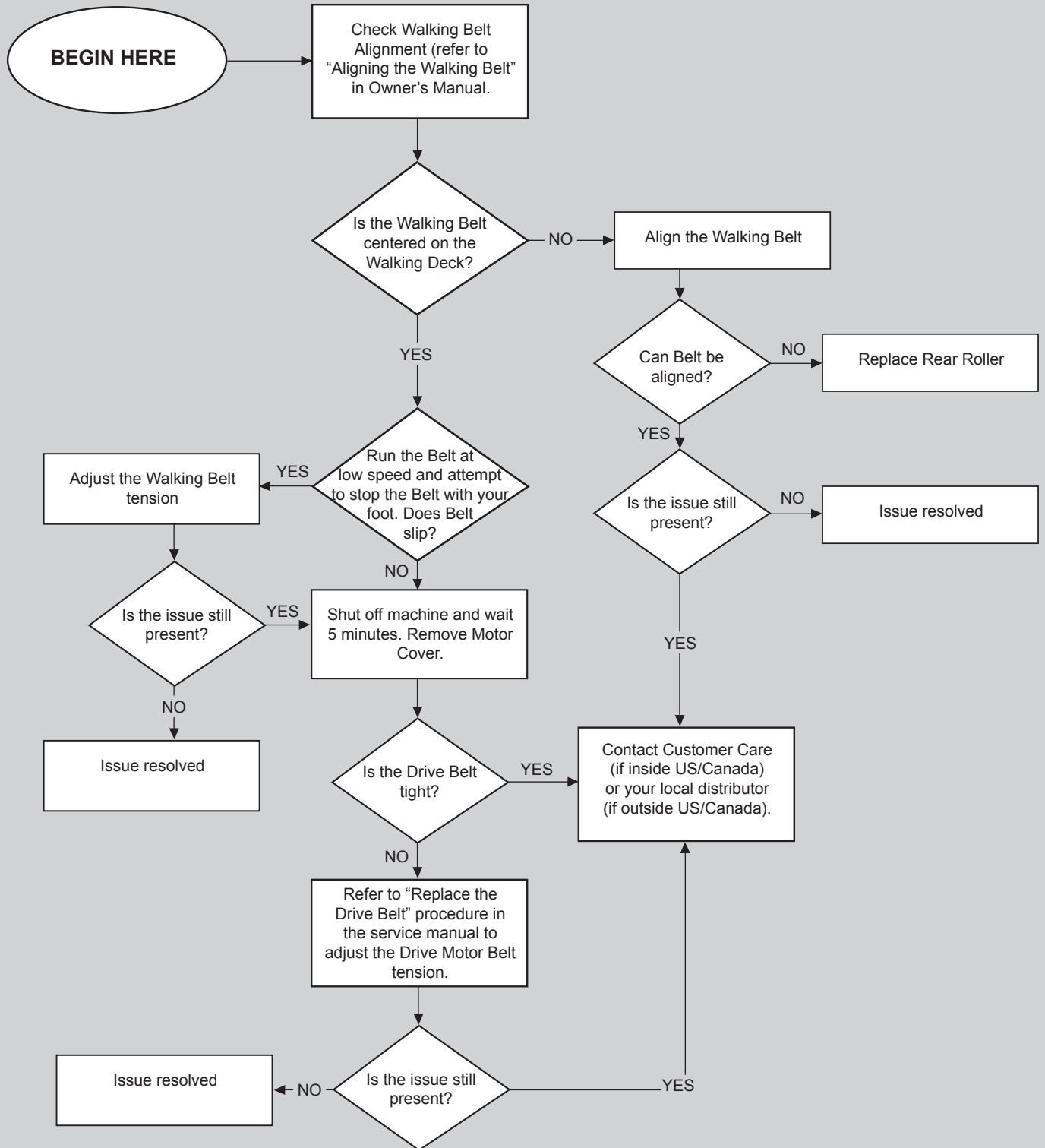

# ELECTRICAL WIRING DIAGRAM

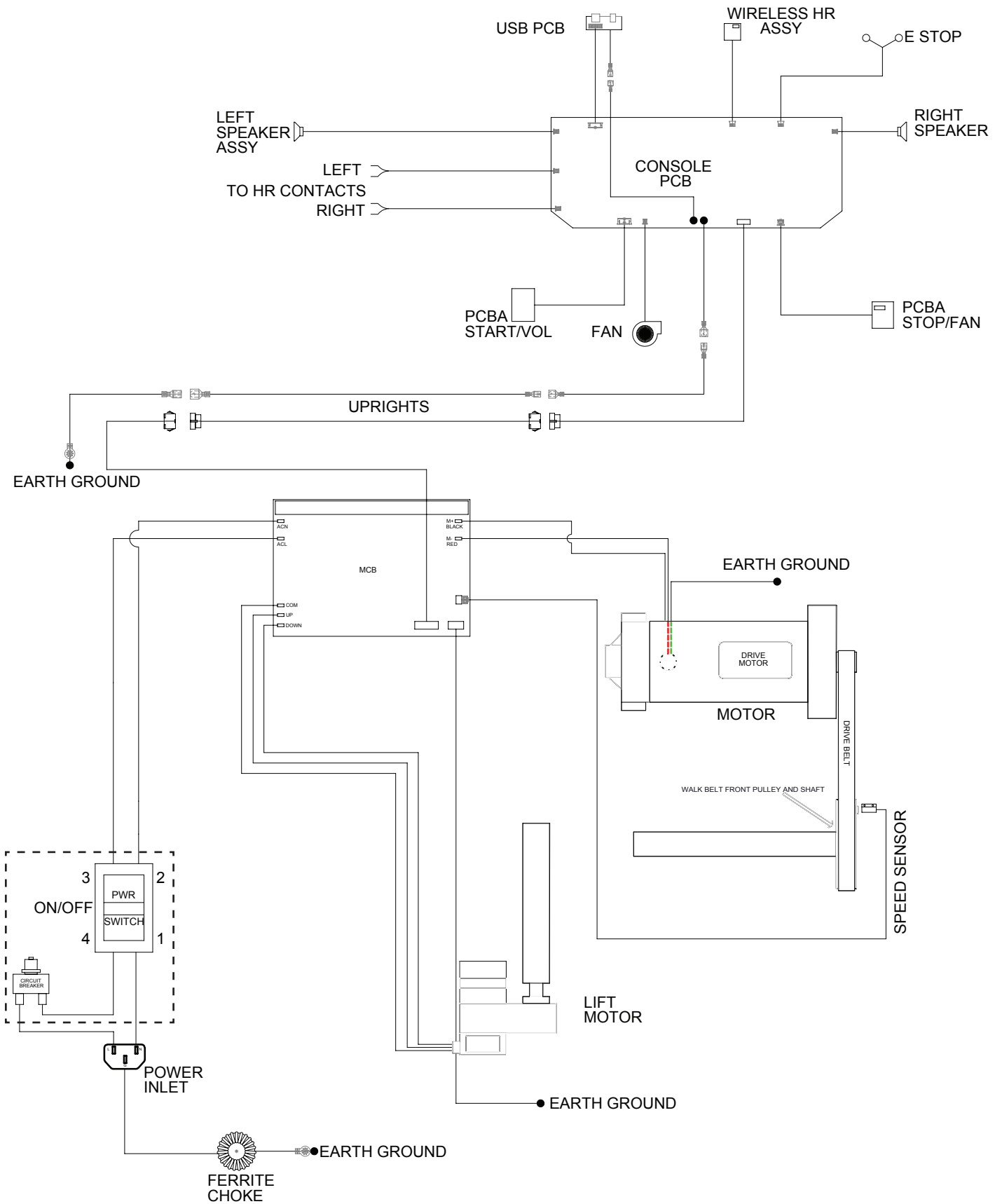

## **Replacement Procedure Skill Level**

- Level I : Low - very little mechanical knowledge or exposure.
- Level II : Intermediate - some experience with mechanical procedures.
- Level III : Advanced - knowledgeable about mechanical procedures.

**NOTICE:** This document provides instructions for the adjustment of the Walking Belt on the Schwinn™ 810 / 510T machine.

If you need assistance, please contact Customer Service (if purchased in US/Canada) or your local distributor (if purchased outside US/Canada). To find your local distributor, go to: [www.nautilusinternational.com](http://www.nautilusinternational.com)

**!** This icon means a potentially hazardous situation which, if not avoided, could result in death or serious injury. Read and understand all Warnings on this machine.

Nautilus, Inc., [www.NautilusInc.com](http://www.NautilusInc.com), 5415 Centerpoint Parkway, Groveport, OH 43125 U.S.A. - Customer Service: North America (800) 605-3369, [csnls@nautilus.com](mailto:csnls@nautilus.com) | outside U.S. [www.nautilusinternational.com](http://www.nautilusinternational.com) | Printed in China | © 2019 Nautilus, Inc. | Schwinn and the Schwinn logo are trademarks owned or licensed by Nautilus, Inc., registered or otherwise protected by common law in the United States and other nations. | **ORIGINAL DOCUMENT - ENGLISH VERSION ONLY**

### Important Safety Instructions - Before servicing or using this equipment, obey the following warnings:

**!** This icon means a potentially hazardous situation which, if not avoided, could result in death or serious injury. Read and understand all Warnings on this machine.

**! DANGER** To reduce the risk of electrical shock or unsupervised usage of the equipment, always unplug the power cord from the wall outlet and wait 5 minutes before cleaning, maintaining or repairing this machine. Place the power cord in a secure location.

- Read and understand the Part Replacement Procedure before working on the machine. Failure to obey the instructions and safety warnings could cause injury to the service technician or bystanders.
- Keep bystanders, children and pets away from the product being serviced at all times.
- Make sure that the repair is done in an appropriate work space away from foot traffic and exposure to bystanders.
- Disconnect all power and allow to sit for 5 minutes before you service this machine.
- Some components of the equipment can be heavy or awkward. Enlist the service of a second person when you do maintenance steps involving these components. Do not try to do heavy or awkward steps on your own.
- If replacement parts are necessary, use only genuine Nautilus replacement parts and hardware. Failure to use genuine replacement parts can cause a risk to users, keep the machine from operating correctly and will void the warranty.
- Be sure that all warning stickers and instructional placards applied to the product stay present and in good condition when doing maintenance or replacing components. If at any time the Warning labels become loose, unreadable or dislodged, replace the labels. If purchased in US/Canada, contact Customer Service for replacement labels. If purchased outside US/Canada, contact your local distributor for them.
- Do not try to change the design or functionality of the machine being serviced as this can adversely effect user safety and will void the warranty.
- Do not use the machine until all shrouds, instructions, warning labels and correct functionality have been verified and tested for correct performance.

### • SAVE THESE INSTRUCTIONS.

#### Tools Required (not included)

6mm hex wrench



1. Run the machine at 1 mph to see which way the Walking Belt needs to be moved.



**Do not touch the Walking Belt. Be sure to keep bystanders, children and pets away from the machine.**

2. Using a 6mm hex wrench on the side the belt should move away from, rotate the Adjustment Bolt a 1/4 turn clock-wise.

3. Allow the Walking Belt to adjust to the new tension.

4. Repeat steps 2 and 3 until the Walking Belt is centered.



5. Final Inspection

Inspect your machine to ensure that all hardware is tight and components are properly assembled.



**Do not use until the machine has been fully assembled and inspected for correct performance in accordance with the Owner's Manual.**

**NOTICE:** This document provides instructions for the replacement of the Bottom Motor Cover on the Schwinn™ 810 / 510T machine.

If you need assistance, please contact Customer Service (if purchased in US/Canada) or your local distributor (if purchased outside US/Canada). To find your local distributor, go to: [www.nautilusinternational.com](http://www.nautilusinternational.com)

 This icon means a potentially hazardous situation which, if not avoided, could result in death or serious injury. Read and understand all Warnings on this machine.

Nautilus, Inc., [www.NautilusInc.com](http://www.NautilusInc.com), 5415 Centerpoint Parkway, Groveport, OH 43125 U.S.A. - Customer Service: North America (800) 605-3369, [csnls@nautilus.com](mailto:csnls@nautilus.com) | outside U.S. [www.nautilusinternational.com](http://www.nautilusinternational.com) | Printed in China | © 2019 Nautilus, Inc. | Schwinn and the Schwinn logo are trademarks owned or licensed by Nautilus, Inc., registered or otherwise protected by common law in the United States and other nations. | **ORIGINAL DOCUMENT - ENGLISH VERSION ONLY**

### Important Safety Instructions - Before servicing or using this equipment, obey the following warnings:

 This icon means a potentially hazardous situation which, if not avoided, could result in death or serious injury. Read and understand all Warnings on this machine.

** DANGER** To reduce the risk of electrical shock or unsupervised usage of the equipment, always unplug the power cord from the wall outlet and wait 5 minutes before cleaning, maintaining or repairing this machine. Place the power cord in a secure location.

- Read and understand the Part Replacement Procedure before working on the machine. Failure to obey the instructions and safety warnings could cause injury to the service technician or bystanders.
- Keep bystanders, children and pets away from the product being serviced at all times.
- Make sure that the repair is done in an appropriate work space away from foot traffic and exposure to bystanders.
- Disconnect all power and allow to sit for 5 minutes before you service this machine.
- Some components of the equipment can be heavy or awkward. Enlist the service of a second person when you do maintenance steps involving these components. Do not try to do heavy or awkward steps on your own.
- If replacement parts are necessary, use only genuine Nautilus replacement parts and hardware. Failure to use genuine replacement parts can cause a risk to users, keep the machine from operating correctly and will void the warranty.
- Be sure that all warning stickers and instructional placards applied to the product stay present and in good condition when doing maintenance or replacing components. If at any time the Warning labels become loose, unreadable or dislodged, replace the labels. If purchased in US/Canada, contact Customer Service for replacement labels. If purchased outside US/Canada, contact your local distributor for them.
- Do not try to change the design or functionality of the machine being serviced as this can adversely effect user safety and will void the warranty.
- Do not use the machine until all shrouds, instructions, warning labels and correct functionality have been verified and tested for correct performance.

### • SAVE THESE INSTRUCTIONS.

#### Tools Required (not included)

#2 Phillips screwdriver

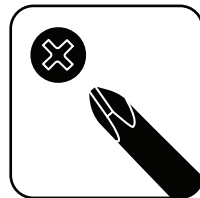

(2) 17mm wrenches

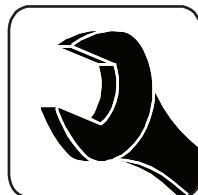



# ⚠ DANGER

To reduce the risk of electrical shock or unsupervised usage of the equipment, always unplug the power cord from the wall outlet and wait 5 minutes before cleaning, maintaining or repairing this machine. Place the power cord in a secure location.

1. Unplug the power cord from the machine and wait 5 minutes. Place the power cord in a secure location.

2. Using a #2 Phillips screwdriver remove the 4 indicated screws from the Motor Cover.



3. Using the support bar found below the rear of the walking belt, lift the walking deck fully upward and engage the hydraulic lift. Be sure that the hydraulic lift is correctly locked in place. You will hear an audible click when the hydraulic lift shifts into the locked position.

**⚠ Use proper safety precautions and lifting techniques. Bend your knees and elbows, keep your back straight and pull up equally with both arms. Straighten your legs to lift. Make sure that your own physical strength is capable of lifting the walking deck until it engages the locking mechanism. Use a second person if necessary.**

**Do not use the walking belt or rear roller to lift the treadmill. These parts do not lock in place and can abruptly move. Injury to you or damage to the machine can occur.**



4. Make sure that the locking mechanism is engaged. Carefully pull back on the walking deck and make sure that it does not move. When you do this, keep clear of movement path in case the treadmill lock is not properly engaged.

**⚠ Do not lean against the treadmill when it is folded. Do not put items on it that could cause it to become unstable or fall.**



5. Using a #2 Phillips screwdriver remove the 2 indicated screws from the Motor Cover and remove it.



6. Make sure there is sufficient space to lower the walking deck.

**!** Keep a minimum clearance behind the machine of 79" (2 m) and 19.7" (0.5 m) on each side. This is the recommended safe distance for access, movement and emergency dismounts from the machine.

7. Make sure there is no object on or around the treadmill to spill or cause blockage from the fully unfolded position.

8. Slightly push the walking deck forward toward the console. With your foot lightly push the top part of the hydraulic lift forward until the locking tube releases and you can pull the walking deck away from the console. Hold up the rear of the walking deck, and move to the side of the machine.

**!** Keep clear of the movement path of the walking deck.

9. The hydraulic lift is set up to drop gradually. Hold onto the walking deck until approximately 2/3 of the movement down. Lower the weight with your legs. Be aware that the walking deck can possibly drop quickly in the last part of the movement.



10. Make sure that there is safe clearance around, on and above the treadmill to one side. Tilt the machine onto the side being sure not to grasp the Console.

**!** A second person is required to assist with the tilting of the machine. Do not tilt the machine unless the walking deck is in the folded, locked position. Be sure there is adequate clearance for the raised deck. Some components of the equipment can be heavy or awkward. Enlist the service of a second person when you do maintenance steps involving these components. Do not try to do heavy or awkward steps on your own.



11. Using two 17mm wrenches, remove the indicated hardware (with oval) from the Incline Motor Assembly.

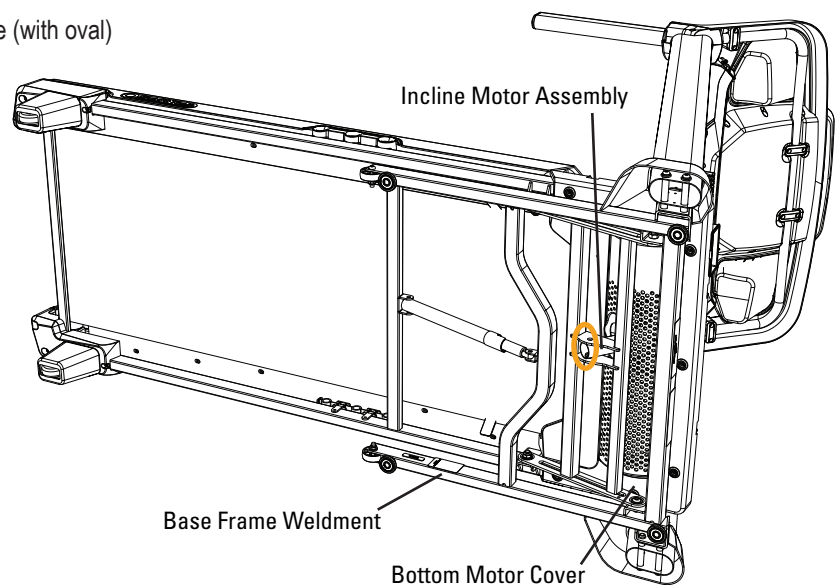

12. Using a #2 Phillips screwdriver, remove the 7 indicated screws from the Bottom Motor Cover.

**Note:** The Base Frame Weldment has been removed for clarity.

13. Remove the old Bottom Motor Cover and attach the new Bottom Motor Cover.

**Note:** Be sure to route the cables from the Base Assembly through the new Bottom Motor Cover.

14. Using two 17mm wrenches in the Motor Compartment, reattach the hardware to the Incline Motor Assembly.

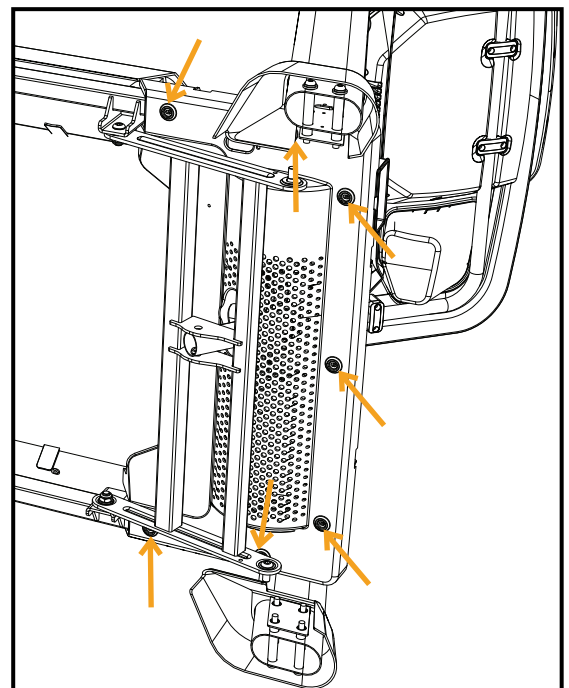

15. Make sure there is sufficient space to tilt the machine back upright and that the area is clear.

 **This step requires two people. Be sure there is adequate clearance for the raised deck. Some components of the equipment can be heavy or awkward. Enlist the service of a second person when you do maintenance steps involving these components. Do not try to do heavy or awkward steps on your own.**

16. Re-install and connect all remaining parts that were removed in reverse order.

17. Final Inspection

Inspect your machine to ensure that all hardware is tight and components are properly assembled.

 **Do not use until the machine has been fully assembled and inspected for correct performance in accordance with the Owner's Manual.**



**NOTICE:** This document provides instructions for the replacement of the Console Assembly on the Schwinn™ 810 / 510T machine.

If you need assistance, please contact Customer Service (if purchased in US/Canada) or your local distributor (if purchased outside US/Canada). To find your local distributor, go to: [www.nautilusinternational.com](http://www.nautilusinternational.com)

**!** This icon means a potentially hazardous situation which, if not avoided, could result in death or serious injury. Read and understand all Warnings on this machine.

Nautilus, Inc., [www.NautilusInc.com](http://www.NautilusInc.com), 5415 Centerpoint Parkway, Groveport, OH 43125 U.S.A. - Customer Service: North America (800) 605-3369, [csnls@nautilus.com](mailto:csnls@nautilus.com) | outside U.S. [www.nautilusinternational.com](http://www.nautilusinternational.com) | Printed in China | © 2019 Nautilus, Inc. | Schwinn and the Schwinn logo are trademarks owned or licensed by Nautilus, Inc., registered or otherwise protected by common law in the United States and other nations. | **ORIGINAL DOCUMENT - ENGLISH VERSION ONLY**

### Important Safety Instructions - Before servicing or using this equipment, obey the following warnings:

**!** This icon means a potentially hazardous situation which, if not avoided, could result in death or serious injury. Read and understand all Warnings on this machine.

**! DANGER** To reduce the risk of electrical shock or unsupervised usage of the equipment, always unplug the power cord from the wall outlet and wait 5 minutes before cleaning, maintaining or repairing this machine. Place the power cord in a secure location.

- Read and understand the Part Replacement Procedure before working on the machine. Failure to obey the instructions and safety warnings could cause injury to the service technician or bystanders.
- Keep bystanders, children and pets away from the product being serviced at all times.
- Make sure that the repair is done in an appropriate work space away from foot traffic and exposure to bystanders.
- Disconnect all power and allow to sit for 5 minutes before you service this machine.
- Some components of the equipment can be heavy or awkward. Enlist the service of a second person when you do maintenance steps involving these components. Do not try to do heavy or awkward steps on your own.
- If replacement parts are necessary, use only genuine Nautilus replacement parts and hardware. Failure to use genuine replacement parts can cause a risk to users, keep the machine from operating correctly and will void the warranty.
- Be sure that all warning stickers and instructional placards applied to the product stay present and in good condition when doing maintenance or replacing components. If at any time the Warning labels become loose, unreadable or dislodged, replace the labels. If purchased in US/Canada, contact Customer Service for replacement labels. If purchased outside US/Canada, contact your local distributor for them.
- Do not try to change the design or functionality of the machine being serviced as this can adversely effect user safety and will void the warranty.
- Do not use the machine until all shrouds, instructions, warning labels and correct functionality have been verified and tested for correct performance.

• **SAVE THESE INSTRUCTIONS.**

#### Tools Required (not included)

#2 Phillips screwdriver

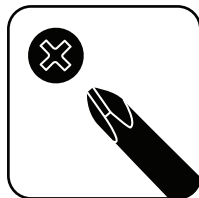

6mm hex wrench



# ⚠ DANGER

To reduce the risk of electrical shock or unsupervised usage of the equipment, always unplug the power cord from the wall outlet and wait 5 minutes before cleaning, maintaining or repairing this machine. Place the power cord in a secure location.

1. Unplug the power cord from the machine and wait 5 minutes. Place the power cord in a secure location.

2. Using a #2 Phillips screwdriver, remove the Handlebar Shrouds from the machine.

*NOTICE:* \* To assist with re-assembly, install the Inner Handlebar Shrouds first.

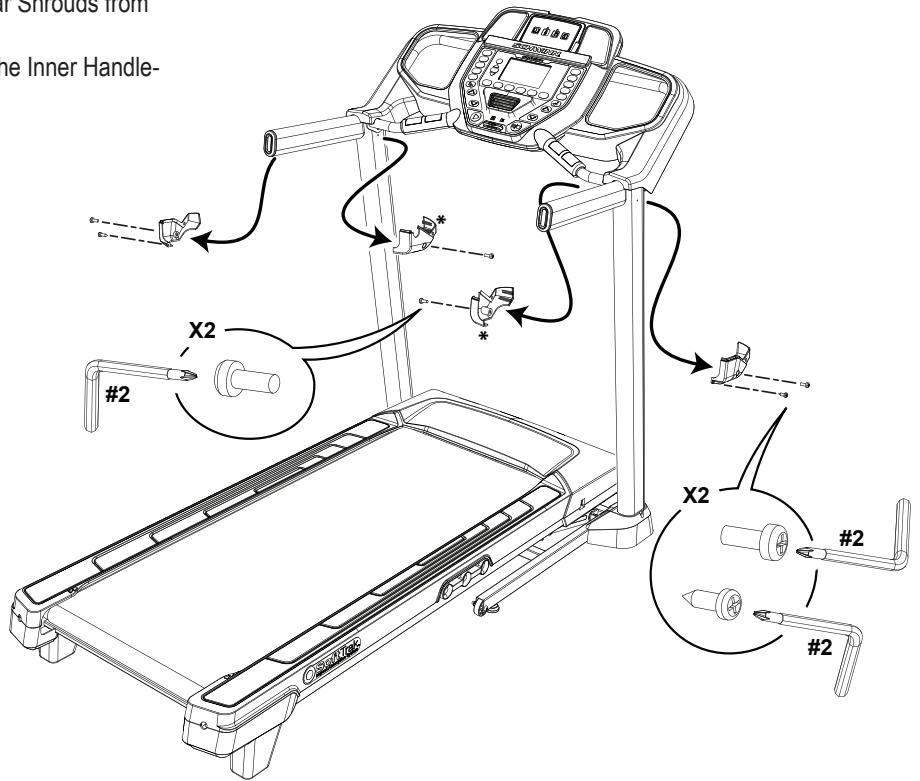

3. Using a 6mm hex wrench, remove the indicated hardware from the machine. Then safely lift the right side of the Console Assembly just enough to expose the Cable Connections. Disconnect the Cables and remove the Console Assembly.

**Note:** This step may require two people.

*NOTICE:* \* To assist with re-assembly, start this hardware first.

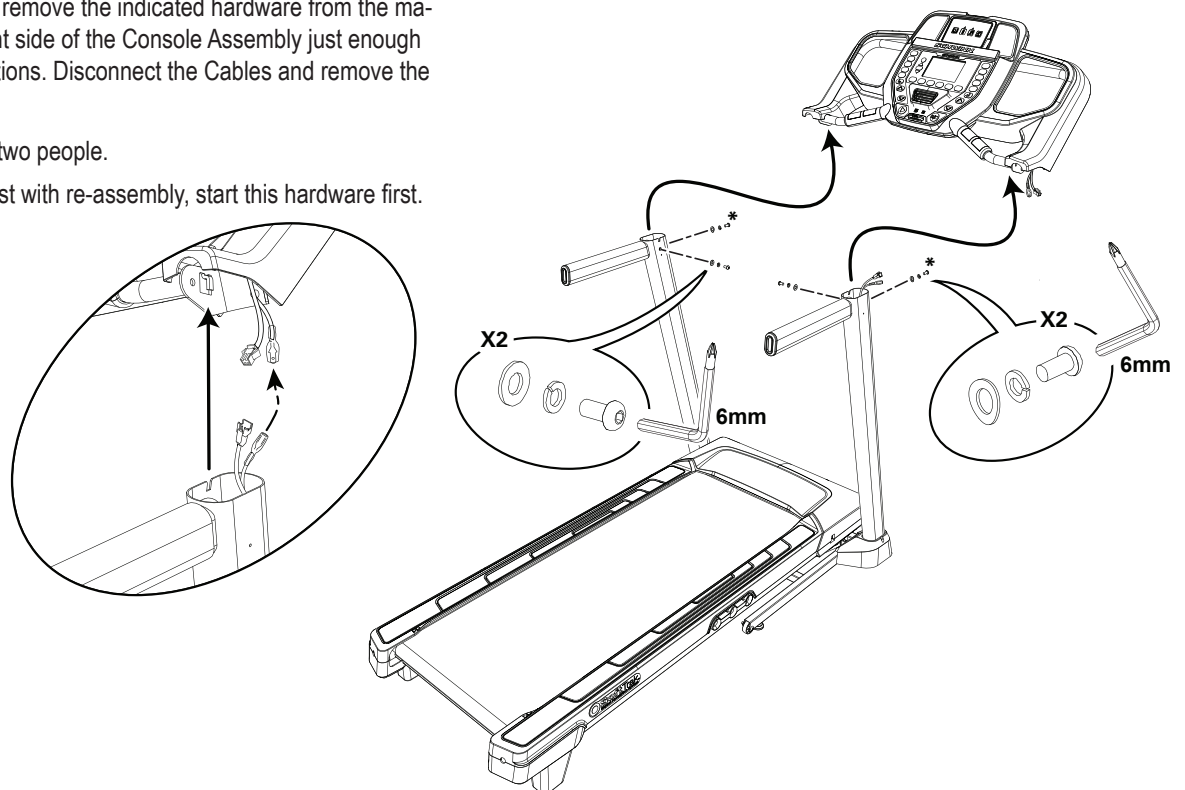

4. Re-install all parts that were removed in reverse order using the new Console Assembly.

5. Final Inspection

Inspect your machine to ensure that all hardware is tight and components are properly assembled.



**Do not use until the machine has been fully assembled and inspected for correct performance in accordance with the Owner's Manual.**

**NOTICE:** This document provides instructions for the replacement of the Deck Suspension on the Schwinn™ 810 / 510T machine.

If you need assistance, please contact Customer Service (if purchased in US/Canada) or your local distributor (if purchased outside US/Canada). To find your local distributor, go to: [www.nautilusinternational.com](http://www.nautilusinternational.com)

 This icon means a potentially hazardous situation which, if not avoided, could result in death or serious injury. Read and understand all Warnings on this machine.

Nautilus, Inc., [www.NautilusInc.com](http://www.NautilusInc.com), 5415 Centerpoint Parkway, Groveport, OH 43125 U.S.A. - Customer Service: North America (800) 605-3369, [csnls@nautilus.com](mailto:csnls@nautilus.com) | outside U.S. [www.nautilusinternational.com](http://www.nautilusinternational.com) | Printed in China | © 2019 Nautilus, Inc. | Schwinn and the Schwinn logo are trademarks owned or licensed by Nautilus, Inc., registered or otherwise protected by common law in the United States and other nations. | **ORIGINAL DOCUMENT - ENGLISH VERSION ONLY**

### Important Safety Instructions - Before servicing or using this equipment, obey the following warnings:

 This icon means a potentially hazardous situation which, if not avoided, could result in death or serious injury. Read and understand all Warnings on this machine.

 **DANGER** To reduce the risk of electrical shock or unsupervised usage of the equipment, always unplug the power cord from the wall outlet and wait 5 minutes before cleaning, maintaining or repairing this machine. Place the power cord in a secure location.

- Read and understand the Part Replacement Procedure before working on the machine. Failure to obey the instructions and safety warnings could cause injury to the service technician or bystanders.
- Keep bystanders, children and pets away from the product being serviced at all times.
- Make sure that the repair is done in an appropriate work space away from foot traffic and exposure to bystanders.
- Disconnect all power and allow to sit for 5 minutes before you service this machine.
- Some components of the equipment can be heavy or awkward. Enlist the service of a second person when you do maintenance steps involving these components. Do not try to do heavy or awkward steps on your own.
- If replacement parts are necessary, use only genuine Nautilus replacement parts and hardware. Failure to use genuine replacement parts can cause a risk to users, keep the machine from operating correctly and will void the warranty.
- Be sure that all warning stickers and instructional placards applied to the product stay present and in good condition when doing maintenance or replacing components. If at any time the Warning labels become loose, unreadable or dislodged, replace the labels. If purchased in US/Canada, contact Customer Service for replacement labels. If purchased outside US/Canada, contact your local distributor for them.
- Do not try to change the design or functionality of the machine being serviced as this can adversely effect user safety and will void the warranty.
- Do not use the machine until all shrouds, instructions, warning labels and correct functionality have been verified and tested for correct performance.

### • SAVE THESE INSTRUCTIONS.

#### Tools Required (not included)

#2 Phillips screwdriver





# ⚠ DANGER

To reduce the risk of electrical shock or unsupervised usage of the equipment, always unplug the power cord from the wall outlet and wait 5 minutes before cleaning, maintaining or repairing this machine. Place the power cord in a secure location.

1. Unplug the power cord from the machine and wait 5 minutes. Place the power cord in a secure location.

2. Make sure that there is safe clearance around, on and above the treadmill. Make sure there is no object to spill or cause blockage from the fully folded position.

⚠ Be sure there is adequate height clearance for the raised deck.

3. Using the support bar found below the rear of the walking belt, lift the walking deck fully upward and engage the hydraulic lift. Be sure that the hydraulic lift is correctly locked in place. You will hear an audible click when the hydraulic lift shifts into the locked position.

⚠ Use proper safety precautions and lifting techniques. Bend your knees and elbows, keep your back straight and pull up equally with both arms. Straighten your legs to lift. Make sure that your own physical strength is capable of lifting the walking deck until it engages the locking mechanism. Use a second person if necessary.

Do not use the walking belt or rear roller to lift the treadmill. These parts do not lock in place and can abruptly move. Injury to you or damage to the machine can occur.

4. Make sure that the locking mechanism is engaged. Carefully pull back on the walking deck and make sure that it does not move. When you do this, keep clear of movement path in case the treadmill lock is not properly engaged.

⚠ Do not lean against the treadmill when it is folded. Do not put items on it that could cause it to become unstable or fall.



5. Using a #2 Phillips screwdriver remove the 2 screws (indicated by arrow) from the Deck Suspensions.

6. Remove the Deck Suspension.

7. Installation of the new Side Rail is the reverse procedure.



8. Make sure there is sufficient space to lower the walking deck.

**⚠ Keep a minimum clearance behind the machine of 79" (2 m) and 19.7" (0.5 m) on each side. This is the recommended safe distance for access, movement and emergency dismounts from the machine.**

9. Make sure there is no object on or around the treadmill to spill or cause blockage from the fully unfolded position.

10. Slightly push the walking deck forward toward the console. With your foot lightly push the top part of the hydraulic lift forward until the locking tube releases and you can pull the walking deck away from the console. Hold up the rear of the walking deck, and move to the side of the machine.



**⚠ Keep clear of the movement path of the walking deck.**

11. The hydraulic lift is set up to drop gradually. Hold onto the walking deck until approximately 2/3 of the movement down. Lower the weight with your legs. Be aware that the walking deck can possibly drop quickly in the last part of the movement.

12. Final Inspection

Inspect your machine to ensure that all hardware is tight and components are properly assembled.

**⚠ Do not use until the machine has been fully assembled and inspected for correct performance in accordance with the Owner's Manual.**

**NOTICE:** This document provides instructions for the replacement of the Deck Wheel on the Schwinn™ 810 / 510T machine.

If you need assistance, please contact Customer Service (if purchased in US/Canada) or your local distributor (if purchased outside US/Canada). To find your local distributor, go to: [www.nautilusinternational.com](http://www.nautilusinternational.com)

**!** This icon means a potentially hazardous situation which, if not avoided, could result in death or serious injury. Read and understand all Warnings on this machine.

Nautilus, Inc., [www.NautilusInc.com](http://www.NautilusInc.com), 5415 Centerpoint Parkway, Groveport, OH 43125 U.S.A. - Customer Service: North America (800) 605-3369, [csnls@nautilus.com](mailto:csnls@nautilus.com) | outside U.S. [www.nautilusinternational.com](http://www.nautilusinternational.com) | Printed in China | © 2019 Nautilus, Inc. | Schwinn and the Schwinn logo are trademarks owned or licensed by Nautilus, Inc., registered or otherwise protected by common law in the United States and other nations. | **ORIGINAL DOCUMENT - ENGLISH VERSION ONLY**

**Important Safety Instructions - Before servicing or using this equipment, obey the following warnings:**

**!** This icon means a potentially hazardous situation which, if not avoided, could result in death or serious injury. Read and understand all Warnings on this machine.

**DANGER** To reduce the risk of electrical shock or unsupervised usage of the equipment, always unplug the power cord from the wall outlet and wait 5 minutes before cleaning, maintaining or repairing this machine. Place the power cord in a secure location.

- Read and understand the Part Replacement Procedure before working on the machine. Failure to obey the instructions and safety warnings could cause injury to the service technician or bystanders.
- Keep bystanders, children and pets away from the product being serviced at all times.
- Make sure that the repair is done in an appropriate work space away from foot traffic and exposure to bystanders.
- Disconnect all power and allow to sit for 5 minutes before you service this machine.
- Some components of the equipment can be heavy or awkward. Enlist the service of a second person when you do maintenance steps involving these components. Do not try to do heavy or awkward steps on your own.
- If replacement parts are necessary, use only genuine Nautilus replacement parts and hardware. Failure to use genuine replacement parts can cause a risk to users, keep the machine from operating correctly and will void the warranty.
- Be sure that all warning stickers and instructional placards applied to the product stay present and in good condition when doing maintenance or replacing components. If at any time the Warning labels become loose, unreadable or dislodged, replace the labels. If purchased in US/Canada, contact Customer Service for replacement labels. If purchased outside US/Canada, contact your local distributor for them.
- Do not try to change the design or functionality of the machine being serviced as this can adversely effect user safety and will void the warranty.
- Do not use the machine until all shrouds, instructions, warning labels and correct functionality have been verified and tested for correct performance.

**• SAVE THESE INSTRUCTIONS.**

**Tools Required (not included)**

6mm hex wrench



13mm wrench





# **⚠ DANGER**

To reduce the risk of electrical shock or unsupervised usage of the equipment, always unplug the power cord from the wall outlet and wait 5 minutes before cleaning, maintaining or repairing this machine. Place the power cord in a secure location.

1. Unplug the power cord from the machine and wait 5 minutes. Place the power cord in a secure location.

2. Make sure that there is safe clearance around, on and above the treadmill. Make sure there is no object to spill or cause blockage from the fully folded position.

**⚠ Be sure there is adequate height clearance for the raised deck.**

3. Using the support bar found below the rear of the walking belt, lift the walking deck fully upward and engage the hydraulic lift. Be sure that the hydraulic lift is correctly locked in place. You will hear an audible click when the hydraulic lift shifts into the locked position.

**⚠ Use proper safety precautions and lifting techniques. Bend your knees and elbows, keep your back straight and pull up equally with both arms. Straighten your legs to lift. Make sure that your own physical strength is capable of lifting the walking deck until it engages the locking mechanism. Use a second person if necessary.**

**Do not use the walking belt or rear roller to lift the treadmill. These parts do not lock in place and can abruptly move. Injury to you or damage to the machine can occur.**

4. Make sure that the locking mechanism is engaged. Carefully pull back on the walking deck and make sure that it does not move. When you do this, keep clear of movement path in case the treadmill lock is not properly engaged.

**⚠ Do not lean against the treadmill when it is folded. Do not put items on it that could cause it to become unstable or fall.**

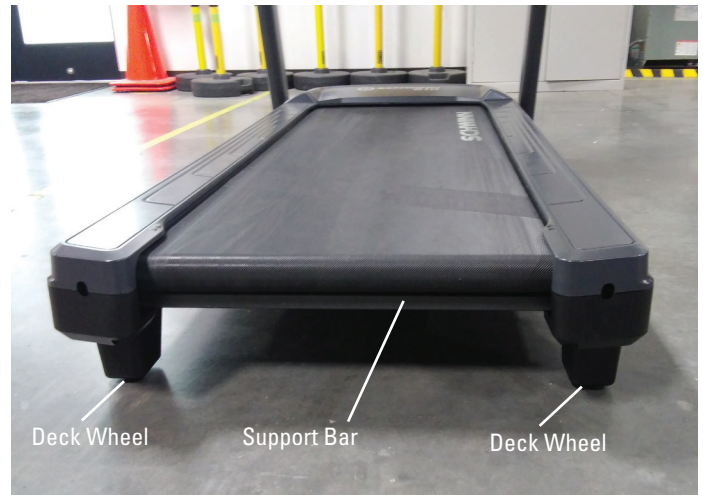

5. Using a #2 Phillips screwdriver, remove the indicated screw (with arrows) from the Rear Roller Cover.

6. Remove the Rear Roller Covers from the machine.

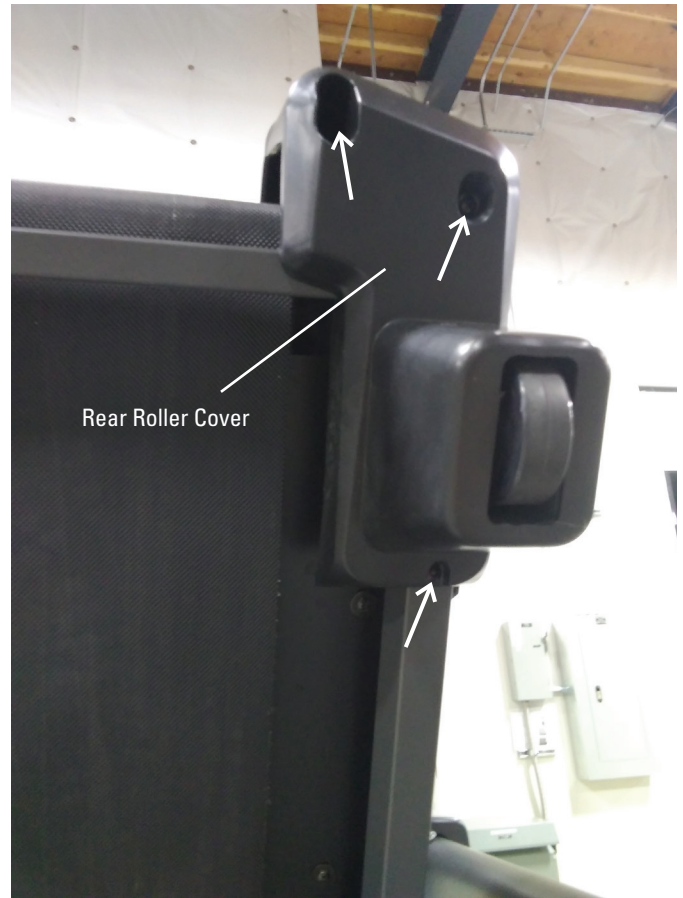

7. Using a 13mm wrench and a 6mm hex wrench, remove the hardware indicated from the Deck Wheel.

8. Remove the old Deck Wheel, and attach the new Deck Wheel.

9. Re-install all remaining parts that were removed in reverse order.



10. Make sure there is sufficient space to lower the walking deck.

**!** Keep a minimum clearance behind the machine of 79" (2 m) and 19.7" (0.5 m) on each side. This is the recommended safe distance for access, movement and emergency dismounts from the machine.

11. Make sure there is no object on or around the treadmill to spill or cause blockage from the fully unfolded position.

12. Slightly push the walking deck forward toward the console. With your foot lightly push the top part of the hydraulic lift forward until the locking tube releases and you can pull the walking deck away from the console. Hold up the rear of the walking deck, and move to the side of the machine.

**!** Keep clear of the movement path of the walking deck.

13. The hydraulic lift is set up to drop gradually. Hold onto the walking deck until approximately 2/3 of the movement down. Lower the weight with your legs. Be aware that the walking deck can possibly drop quickly in the last part of the movement.

14. Final Inspection

Inspect your machine to ensure that all hardware is tight and components are properly assembled.

**!** Do not use until the machine has been fully assembled and inspected for correct performance in accordance with the Owner's Manual.



**NOTICE:** This document provides instructions for the replacement of the Drive Belt on the Schwinn™ 810 / 510T machine.

If you need assistance, please contact Customer Service (if purchased in US/Canada) or your local distributor (if purchased outside US/Canada). To find your local distributor, go to: [www.nautilusinternational.com](http://www.nautilusinternational.com)

**!** This icon means a potentially hazardous situation which, if not avoided, could result in death or serious injury. Read and understand all Warnings on this machine.

Nautilus, Inc., [www.NautilusInc.com](http://www.NautilusInc.com), 5415 Centerpoint Parkway, Groveport, OH 43125 U.S.A. - Customer Service: North America (800) 605-3369, [csnls@nautilus.com](mailto:csnls@nautilus.com) | outside U.S. [www.nautilusinternational.com](http://www.nautilusinternational.com) | Printed in China | © 2019 Nautilus, Inc. | Schwinn and the Schwinn logo are trademarks owned or licensed by Nautilus, Inc., registered or otherwise protected by common law in the United States and other nations. | **ORIGINAL DOCUMENT - ENGLISH VERSION ONLY**

### Important Safety Instructions - Before servicing or using this equipment, obey the following warnings:

**!** This icon means a potentially hazardous situation which, if not avoided, could result in death or serious injury. Read and understand all Warnings on this machine.

**! DANGER** To reduce the risk of electrical shock or unsupervised usage of the equipment, always unplug the power cord from the wall outlet and wait 5 minutes before cleaning, maintaining or repairing this machine. Place the power cord in a secure location.

- Read and understand the Part Replacement Procedure before working on the machine. Failure to obey the instructions and safety warnings could cause injury to the service technician or bystanders.
- Keep bystanders, children and pets away from the product being serviced at all times.
- Make sure that the repair is done in an appropriate work space away from foot traffic and exposure to bystanders.
- Disconnect all power and allow to sit for 5 minutes before you service this machine.
- Some components of the equipment can be heavy or awkward. Enlist the service of a second person when you do maintenance steps involving these components. Do not try to do heavy or awkward steps on your own.
- If replacement parts are necessary, use only genuine Nautilus replacement parts and hardware. Failure to use genuine replacement parts can cause a risk to users, keep the machine from operating correctly and will void the warranty.
- Be sure that all warning stickers and instructional placards applied to the product stay present and in good condition when doing maintenance or replacing components. If at any time the Warning labels become loose, unreadable or dislodged, replace the labels. If purchased in US/Canada, contact Customer Service for replacement labels. If purchased outside US/Canada, contact your local distributor for them.
- Do not try to change the design or functionality of the machine being serviced as this can adversely effect user safety and will void the warranty.
- Do not use the machine until all shrouds, instructions, warning labels and correct functionality have been verified and tested for correct performance.

### • SAVE THESE INSTRUCTIONS.

#### Tools Required (not included)

#2 Phillips screwdriver

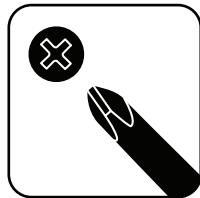

8300 Silicone Spray or Lube-N-Walk® Treadmill Lubrication Kit

6mm hex wrench



13mm wrench





# ⚠ DANGER

To reduce the risk of electrical shock or unsupervised usage of the equipment, always unplug the power cord from the wall outlet and wait 5 minutes before cleaning, maintaining or repairing this machine. Place the power cord in a secure location.

1. Unplug the power cord from the machine and wait 5 minutes. Place the power cord in a secure location.

2. Using a 6mm hex wrench, loosen the Walking Belt with the Adjustment Bolts found on both Rear Roller Covers. Loosen the Adjustment Bolts only until the Walking Belt slides past the Rollers freely. Do not loosen the Adjustment Bolts too much or the Rear Roller may detach.

**Note:** Be sure to record the number of turns of the Adjustment Bolts it takes to loosen the Walking Belt. This will assist with reassembly.

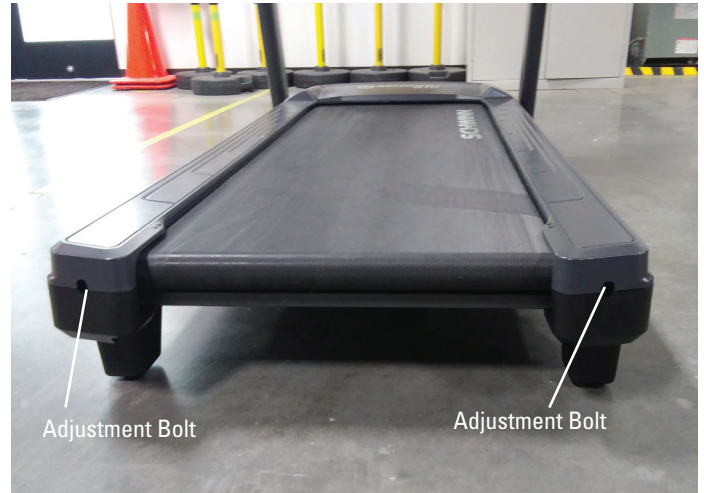

3. Using a #2 Phillips screwdriver remove the 4 indicated screws from the Motor Cover.



4. Make sure that there is safe clearance around, on and above the treadmill. Make sure there is no object to spill or cause blockage from the fully folded position.

**⚠ Be sure there is adequate height clearance for the raised deck.**

5. Using the support bar found below the rear of the walking belt, lift the walking deck fully upward and engage the hydraulic lift. Be sure that the hydraulic lift is correctly locked in place. You will hear an audible click when the hydraulic lift shifts into the locked position.

**⚠ Use proper safety precautions and lifting techniques. Bend your knees and elbows, keep your back straight and pull up equally with both arms. Straighten your legs to lift. Make sure that your own physical strength is capable of lifting the walking deck until it engages the locking mechanism. Use a second person if necessary.**

**Do not use the walking belt or rear roller to lift the treadmill. These parts do not lock in place and can abruptly move. Injury to you or damage to the machine can occur.**





6. Make sure that the locking mechanism is engaged. Carefully pull back on the walking deck and make sure that it does not move. When you do this, keep clear of movement path in case the treadmill lock is not properly engaged.

**!** Do not lean against the treadmill when it is folded. Do not put items on it that could cause it to become unstable or fall.

7. Using a #2 Phillips screwdriver remove the 2 indicated screws from the Motor Cover and remove it.



8. Make sure there is sufficient space to lower the walking deck.

**!** Keep a minimum clearance behind the machine of 79" (2 m) and 19.7" (0.5 m) on each side. This is the recommended safe distance for access, movement and emergency dismounts from the machine.

9. Make sure there is no object on or around the treadmill to spill or cause blockage from the fully unfolded position.

10. Slightly push the walking deck forward toward the console. With your foot lightly push the top part of the hydraulic lift forward until the locking tube releases and you can pull the walking deck away from the console. Hold up the rear of the walking deck, and move to the side of the machine.

**!** Keep clear of the movement path of the walking deck.

11. The hydraulic lift is set up to drop gradually. Hold onto the walking deck until approximately 2/3 of the movement down. Lower the weight with your legs. Be aware that the walking deck can possibly drop quickly in the last part of the movement.



12. Be sure to observe the distance from the Speed Sensor to the Drive Pulley. This distance affects the effectiveness of the Speed Sensor, and can easily be shifted accidentally during replacement procedures.

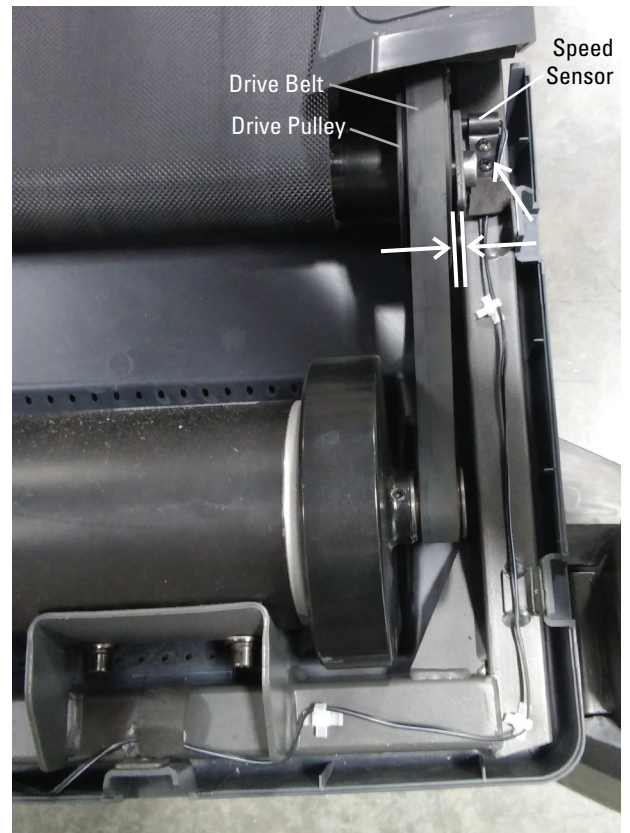

13. Using a 6mm hex wrench, remove the indicated screw from the Front Roller.

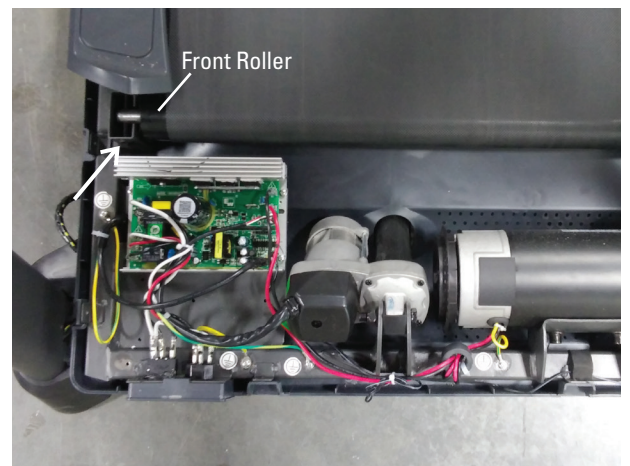

**Note:** Your machine may not match the provided images exactly.

14. Lift and pivot the Front Roller out of the Frame, and slide it out of the Walking Belt. This will free the Drive Belt from the Front Roller.

15. Loop the new Drive Belt around the Front Roller. Insert the end of the Front Roller with the Drive Pulley into the Frame and pivot the other end into the Bracket.

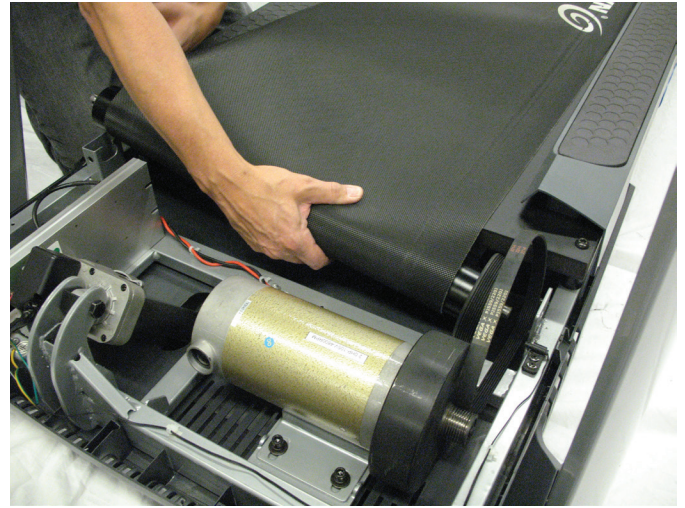

16. Using a 6mm hex wrench, attach the Front Roller to the Bracket.

**Note:** Tighten the hardware until the Front Roller is centered in the Bracket.

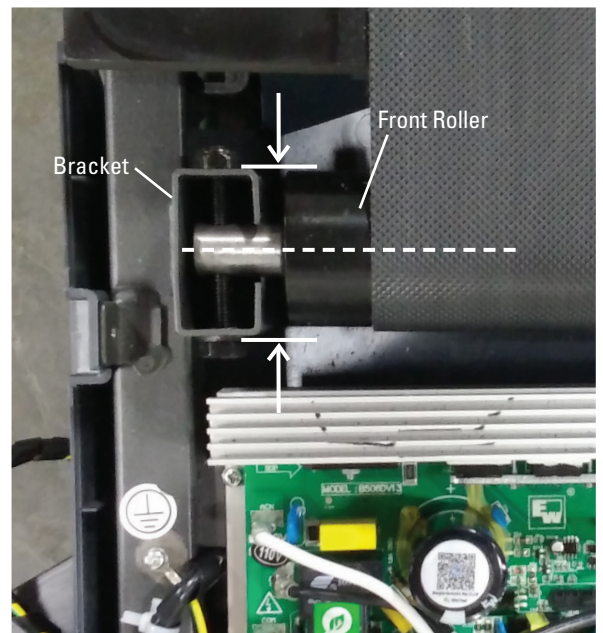

17. Loop the Drive Belt around the Motor Pulley. Start the Drive Belt on the Drive Pulley and roll it in a clockwise motion. Be sure the Belt does not come off of the Motor Pulley.

 **Keep fingers out of any pinch opportunities when turning the Pulleys.**

18. Roll the Drive Pulley clockwise until the Drive Belt is fully installed. Continue to roll the Belt forward while adding side pressure with fingers to align as necessary.

19. Inspect the Speed Sensor to see if it has been moved during the procedure. If necessary, adjust it to be the appropriate distance from the Drive Pulley.

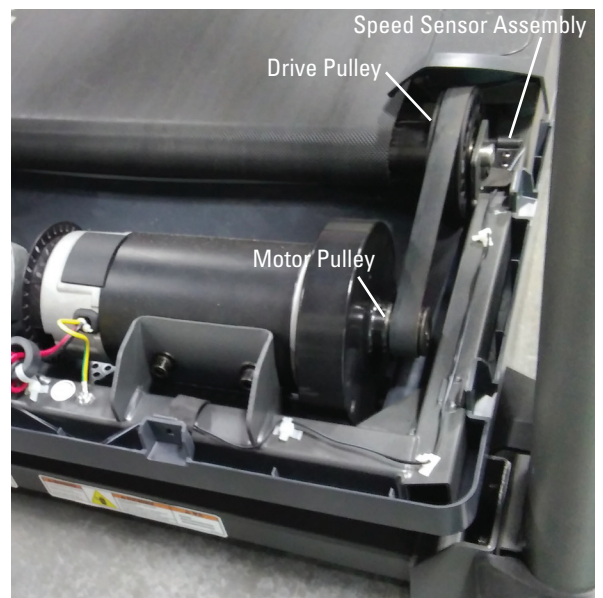



20. Re-install all remaining parts that were removed in reverse order.

21. Inspect the surface material below the Treadmill. If the surface material is difficult to clean or could be damaged by silicone lubricant, place absorbent material (such as cardboard or newspaper) below the length of the Walking Deck.

22. Make sure that there is safe clearance around, on and above the treadmill. Make sure there is no object to spill or cause blockage from the fully folded position.

**!** Be sure there is adequate height clearance for the raised deck.

23. Using the support bar found below the rear of the walking belt, lift the walking deck fully upward and engage the hydraulic lift. Be sure that the hydraulic lift is correctly locked in place. You will hear an audible click when the hydraulic lift shifts into the locked position.

**!** Use proper safety precautions and lifting techniques. Bend your knees and elbows, keep your back straight and pull up equally with both arms. Straighten your legs to lift. Make sure that your own physical strength is capable of lifting the walking deck until it engages the locking mechanism. Use a second person if necessary.

**Do not use the walking belt or rear roller to lift the treadmill. These parts do not lock in place and can abruptly move. Injury to you or damage to the machine can occur.**

24. Make sure that the locking mechanism is engaged. Carefully pull back on the walking deck and make sure that it does not move. When you do this, keep clear of movement path in case the treadmill lock is not properly engaged.

**!** Do not lean against the treadmill when it is folded. Do not put items on it that could cause it to become unstable or fall.

25. Apply a few drops of lubricant to the inner surface of the belt for the entire width of the belt. A very thin layer of silicone lubricant on the entire deck below the belt is desired.

*NOTICE:* Always use a 100% silicone lubricant. Do not use a degreaser like WD-40® as this could seriously impact performance. We can recommend that you use the following:

- 8300 Silicone Spray, available at most Hardware and Auto Parts stores.
- Lube-N-Walk® Treadmill Lubrication Kit, available from your local specialty fitness dealer or Nautilus, Inc.

26. Manually rotate the belt 1/2 of the length of the belt and apply lubricant again.



27. Make sure there is sufficient space to lower the walking deck.

**⚠ Keep a minimum clearance behind the machine of 79" (2 m) and 19.7" (0.5 m) on each side. This is the recommended safe distance for access, movement and emergency dismounts from the machine.**

28. Make sure there is no object on or around the treadmill to spill or cause blockage from the fully unfolded position.

29. Slightly push the walking deck forward toward the console. With your foot lightly push the top part of the hydraulic lift forward until the locking tube releases and you can pull the walking deck away from the console. Hold up the rear of the walking deck, and move to the side of the machine.

**⚠ Keep clear of the movement path of the walking deck.**

30. The hydraulic lift is set up to drop gradually. Hold onto the walking deck until approximately 2/3 of the movement down. Lower the weight with your legs. Be aware that the walking deck can possibly drop quickly in the last part of the movement.

**⚠ If you used spray lubricant, wait 5 minutes before turning on power to the machine to allow the aerosol to dissipate.**

31. Attach the power cord and turn on the Treadmill by flipping the power switch to ON.

32. Start the belt at the slowest speed and stand well behind the machine. Let the belt operate for approximately 15 seconds. Notice if the Walking Belt needs to be adjusted so it runs centered on the machine.

**⚠ Be sure not to touch the walking belt or step on the power cord. Keep bystanders, children and pets away from the machine you are servicing at all times.**

33. If the Walking Belt needs to be adjusted, use a 6mm hex wrench on the side the belt should move away from and rotate the Adjustment Bolt a 1/4 turn clock-wise.

34. Allow the Walking Belt to adjust to the new tension by allowing it to run a couple seconds.

35. Repeat steps 33 and 34 until the Walking Belt is centered.

36. Switch off your machine.

37. Take care to clean up any excess lubricant from the deck.

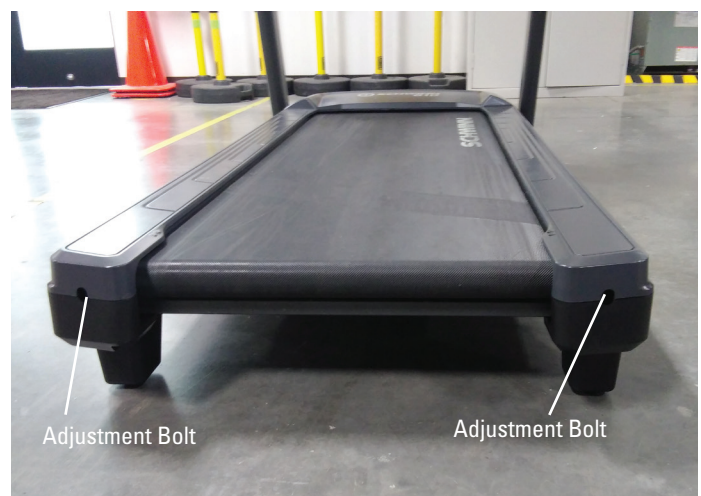

 To decrease the possibility of slipping, be sure the deck area is free from grease or oil. Clean off any excess oil from the machine surfaces.

38. Final Inspection

Inspect your machine to ensure that all hardware is tight and components are properly assembled.

 Do not use until the machine has been fully assembled and inspected for correct performance in accordance with the Owner's Manual.

**NOTICE:** This document provides instructions for the replacement of the Front Roller on the Schwinn™ 810 / 510T machine.

If you need assistance, please contact Customer Service (if purchased in US/Canada) or your local distributor (if purchased outside US/Canada). To find your local distributor, go to: [www.nautilusinternational.com](http://www.nautilusinternational.com)

**!** This icon means a potentially hazardous situation which, if not avoided, could result in death or serious injury. Read and understand all Warnings on this machine.

Nautilus, Inc., [www.NautilusInc.com](http://www.NautilusInc.com), 5415 Centerpoint Parkway, Groveport, OH 43125 U.S.A. - Customer Service: North America (800) 605-3369, [csnls@nautilus.com](mailto:csnls@nautilus.com) | outside U.S. [www.nautilusinternational.com](http://www.nautilusinternational.com) | Printed in China | © 2019 Nautilus, Inc. | Schwinn and the Schwinn logo are trademarks owned or licensed by Nautilus, Inc., registered or otherwise protected by common law in the United States and other nations. | **ORIGINAL DOCUMENT - ENGLISH VERSION ONLY**

**Important Safety Instructions - Before servicing or using this equipment, obey the following warnings:**

**!** This icon means a potentially hazardous situation which, if not avoided, could result in death or serious injury. Read and understand all Warnings on this machine.

**! DANGER** To reduce the risk of electrical shock or unsupervised usage of the equipment, always unplug the power cord from the wall outlet and wait 5 minutes before cleaning, maintaining or repairing this machine. Place the power cord in a secure location.

- Read and understand the Part Replacement Procedure before working on the machine. Failure to obey the instructions and safety warnings could cause injury to the service technician or bystanders.
- Keep bystanders, children and pets away from the product being serviced at all times.
- Make sure that the repair is done in an appropriate work space away from foot traffic and exposure to bystanders.
- Disconnect all power and allow to sit for 5 minutes before you service this machine.
- Some components of the equipment can be heavy or awkward. Enlist the service of a second person when you do maintenance steps involving these components. Do not try to do heavy or awkward steps on your own.
- If replacement parts are necessary, use only genuine Nautilus replacement parts and hardware. Failure to use genuine replacement parts can cause a risk to users, keep the machine from operating correctly and will void the warranty.
- Be sure that all warning stickers and instructional placards applied to the product stay present and in good condition when doing maintenance or replacing components. If at any time the Warning labels become loose, unreadable or dislodged, replace the labels. If purchased in US/Canada, contact Customer Service for replacement labels. If purchased outside US/Canada, contact your local distributor for them.
- Do not try to change the design or functionality of the machine being serviced as this can adversely effect user safety and will void the warranty.
- Do not use the machine until all shrouds, instructions, warning labels and correct functionality have been verified and tested for correct performance.

**• SAVE THESE INSTRUCTIONS.**

**Tools Required (not included)**

#2 Phillips screwdriver

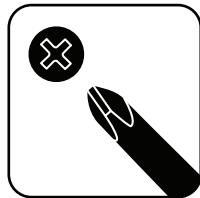

8300 Silicone Spray or Lube-N-Walk® Treadmill Lubrication Kit

6mm hex wrench



13mm wrench





# ⚠ DANGER

To reduce the risk of electrical shock or unsupervised usage of the equipment, always unplug the power cord from the wall outlet and wait 5 minutes before cleaning, maintaining or repairing this machine. Place the power cord in a secure location.

1. Unplug the power cord from the machine and wait 5 minutes. Place the power cord in a secure location.

2. Using a 6mm hex wrench, loosen the Walking Belt with the Adjustment Bolts found on both Rear Roller Covers. Loosen the Adjustment Bolts only until the Walking Belt slides past the Rollers freely. Do not loosen the Adjustment Bolts too much or the Rear Roller may detach.

**Note:** Be sure to record the number of turns of the Adjustment Bolts it takes to loosen the Walking Belt. This will assist with reassembly.

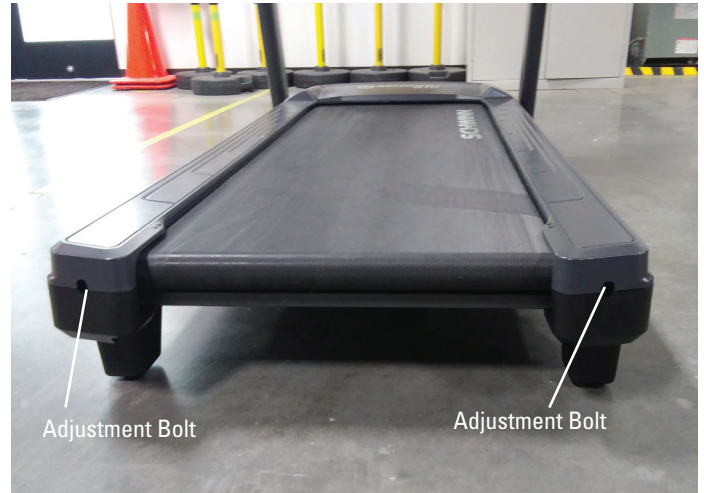

3. Using a #2 Phillips screwdriver remove the 4 indicated screws from the Motor Cover.



4. Make sure that there is safe clearance around, on and above the treadmill. Make sure there is no object to spill or cause blockage from the fully folded position.

**⚠** Be sure there is adequate height clearance for the raised deck.

5. Using the support bar found below the rear of the walking belt, lift the walking deck fully upward and engage the hydraulic lift. Be sure that the hydraulic lift is correctly locked in place. You will hear an audible click when the hydraulic lift shifts into the locked position.

**⚠** Use proper safety precautions and lifting techniques. Bend your knees and elbows, keep your back straight and pull up equally with both arms. Straighten your legs to lift. Make sure that your own physical strength is capable of lifting the walking deck until it engages the locking mechanism. Use a second person if necessary.

Do not use the walking belt or rear roller to lift the treadmill. These parts do not lock in place and can abruptly move. Injury to you or damage to the machine can occur.





6. Make sure that the locking mechanism is engaged. Carefully pull back on the walking deck and make sure that it does not move. When you do this, keep clear of movement path in case the treadmill lock is not properly engaged.

**!** Do not lean against the treadmill when it is folded. Do not put items on it that could cause it to become unstable or fall.

7. Using a #2 Phillips screwdriver remove the 2 indicated screws from the Motor Cover and remove it.



8. Make sure there is sufficient space to lower the walking deck.

**!** Keep a minimum clearance behind the machine of 79" (2 m) and 19.7" (0.5 m) on each side. This is the recommended safe distance for access, movement and emergency dismounts from the machine.

9. Make sure there is no object on or around the treadmill to spill or cause blockage from the fully unfolded position.

10. Slightly push the walking deck forward toward the console. With your foot lightly push the top part of the hydraulic lift forward until the locking tube releases and you can pull the walking deck away from the console. Hold up the rear of the walking deck, and move to the side of the machine.

**!** Keep clear of the movement path of the walking deck.

11. The hydraulic lift is set up to drop gradually. Hold onto the walking deck until approximately 2/3 of the movement down. Lower the weight with your legs. Be aware that the walking deck can possibly drop quickly in the last part of the movement.



12. Be sure to observe the distance from the Speed Sensor to the Drive Pulley. This distance affects the effectiveness of the Speed Sensor, and can easily be shifted accidentally during replacement procedures.

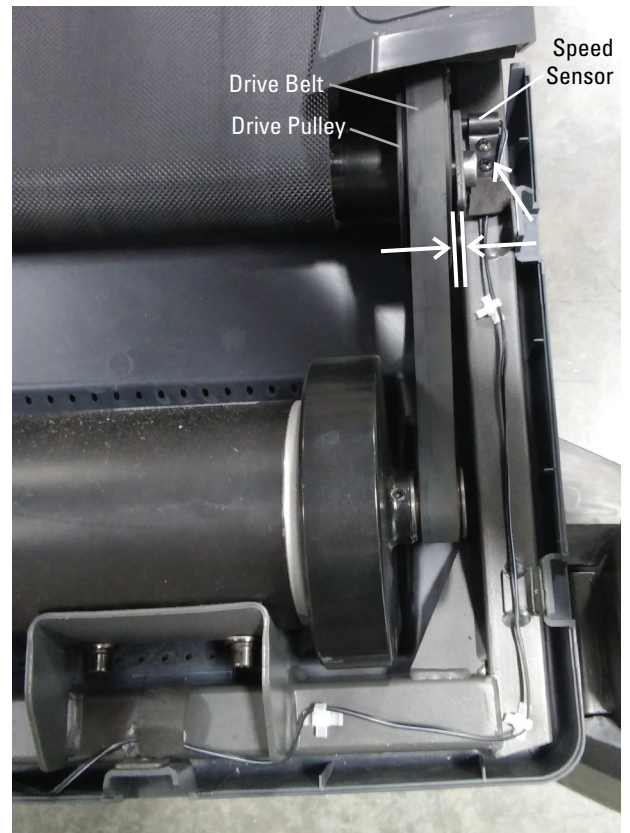

13. Using a 6mm hex wrench, remove the indicated screw from the Front Roller.

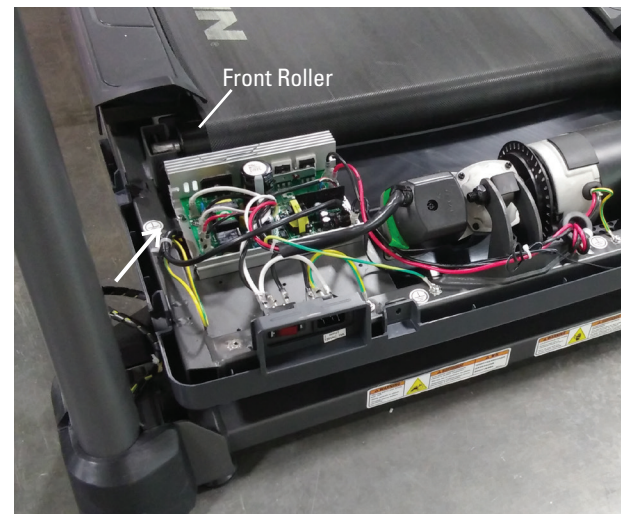



**Note:** Your machine may not match the provided images exactly.

14. Lift and pivot the Front Roller out of the Frame, and slide it out of the Walking Belt. This will free the Drive Belt from the Front Roller.

15. Loop the Drive Belt around the new Front Roller. Insert the end of the Front Roller with the Drive Pulley into the Frame and pivot the other end into the Bracket.

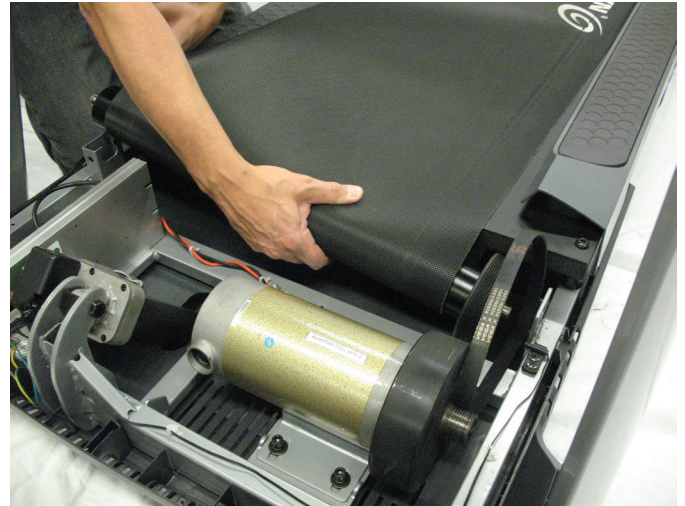

16. Using a 6mm hex wrench, attach the Front Roller to the Bracket.

**Note:** Tighten the hardware until the Front Roller is centered in the Bracket.

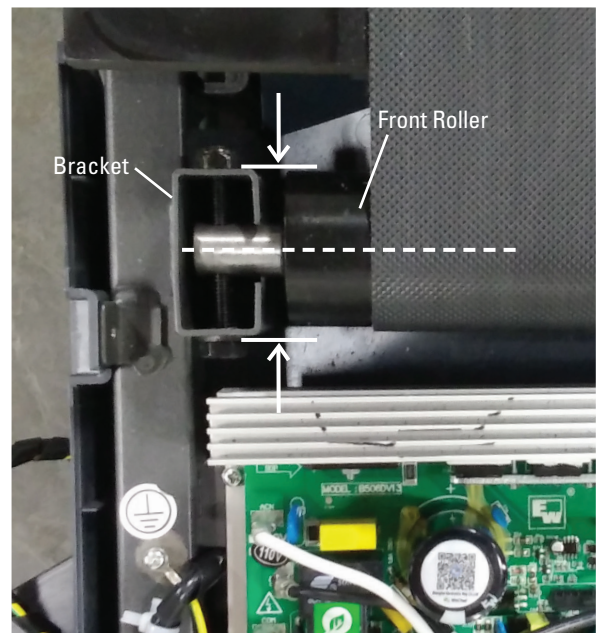

17. Loop the Drive Belt around the Motor Pulley. Start the Drive Belt on the Drive Pulley and roll it in a clockwise motion. Be sure the Belt does not come off of the Motor Pulley.

 **Keep fingers out of any pinch opportunities when turning the Pulleys.**

18. Roll the Drive Pulley clockwise until the Drive Belt is fully installed. Continue to roll the Belt forward while adding side pressure with fingers to align as necessary.

19. Inspect the Speed Sensor to see if it has been moved during the procedure. If necessary, adjust it to be the appropriate distance from the Drive Pulley.

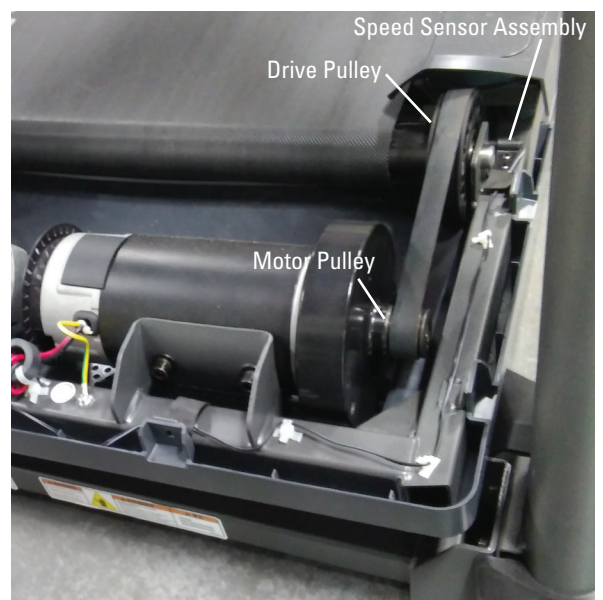

20. Re-install all remaining parts that were removed in reverse order.

**Note:** Make sure the treadmill is located on a surface that is easy to clean.

21. Make sure that there is safe clearance around, on and above the treadmill. Make sure there is no object to spill or cause blockage from the fully folded position.

**!** Be sure there is adequate height clearance for the raised deck.

22. Using the support bar found below the rear of the walking belt, lift the walking deck fully upward and engage the hydraulic lift. Be sure that the hydraulic lift is correctly locked in place. You will hear an audible click when the hydraulic lift shifts into the locked position.

**!** Use proper safety precautions and lifting techniques. Bend your knees and elbows, keep your back straight and pull up equally with both arms. Straighten your legs to lift. Make sure that your own physical strength is capable of lifting the walking deck until it engages the locking mechanism. Use a second person if necessary.

**Do not use the walking belt or rear roller to lift the treadmill. These parts do not lock in place and can abruptly move. Injury to you or damage to the machine can occur.**

23. Make sure that the locking mechanism is engaged. Carefully pull back on the walking deck and make sure that it does not move. When you do this, keep clear of movement path in case the treadmill lock is not properly engaged.

**!** Do not lean against the treadmill when it is folded. Do not put items on it that could cause it to become unstable or fall.

24. Apply a few drops of lubricant to the inner surface of the belt for the entire width of the belt. A very thin layer of silicone lubricant on the entire deck below the belt is desired.

*NOTICE:* Always use a 100% silicone lubricant. Do not use a degreaser like WD-40® as this could seriously impact performance. We can recommend that you use the following:

- 8300 Silicone Spray, available at most Hardware and Auto Parts stores.
- Lube-N-Walk® Treadmill Lubrication Kit, available from your local specialty fitness dealer or Nautilus, Inc.

25. Manually rotate the belt 1/2 of the length of the belt and apply lubricant again.



26. Make sure there is sufficient space to lower the walking deck.

**⚠ Keep a minimum clearance behind the machine of 79" (2 m) and 19.7" (0.5 m) on each side. This is the recommended safe distance for access, movement and emergency dismounts from the machine.**

27. Make sure there is no object on or around the treadmill to spill or cause blockage from the fully unfolded position.

28. Slightly push the walking deck forward toward the console. With your foot lightly push the top part of the hydraulic lift forward until the locking tube releases and you can pull the walking deck away from the console. Hold up the rear of the walking deck, and move to the side of the machine.

**⚠ Keep clear of the movement path of the walking deck.**

29. The hydraulic lift is set up to drop gradually. Hold onto the walking deck until approximately 2/3 of the movement down. Lower the weight with your legs. Be aware that the walking deck can possibly drop quickly in the last part of the movement.

**⚠ If you used spray lubricant, wait 5 minutes before turning on power to the machine to allow the aerosol to dissipate.**

30. Attach the power cord and turn on the Treadmill by flipping the power switch to ON.

31. Start the belt at the slowest speed and stand well behind the machine. Let the belt operate for approximately 15 seconds. Notice if the Walking Belt needs to be adjusted so it runs centered on the machine.

**⚠ Be sure not to touch the walking belt or step on the power cord. Keep bystanders, children and pets away from the machine you are servicing at all times.**

32. If the Walking Belt needs to be adjusted, use a 6mm hex wrench on the side the belt should move away from and rotate the Adjustment Bolt a 1/4 turn clock-wise.

33. Allow the Walking Belt to adjust to the new tension by allowing it to run a couple seconds.

34. Repeat steps 44 and 45 until the Walking Belt is centered.

35. Switch off your machine.

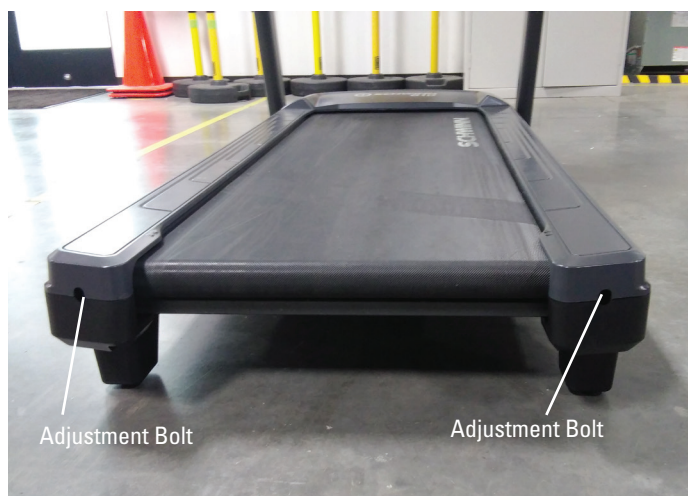

36. Take care to clean up any excess lubricant from the deck.

 **To decrease the possibility of slipping, be sure the deck area is free from grease or oil. Clean off any excess oil from the machine surfaces.**

37. Final Inspection

Inspect your machine to ensure that all hardware is tight and components are properly assembled.

 **Do not use until the machine has been fully assembled and inspected for correct performance in accordance with the Owner's Manual.**



**NOTICE:** This document provides instructions for the replacement of the Incline Motor Assembly on the Schwinn™ 810 / 510T machine.

If you need assistance, please contact Customer Service (if purchased in US/Canada) or your local distributor (if purchased outside US/Canada). To find your local distributor, go to: [www.nautilusinternational.com](http://www.nautilusinternational.com)

**!** This icon means a potentially hazardous situation which, if not avoided, could result in death or serious injury. Read and understand all Warnings on this machine.

Nautilus, Inc., [www.NautilusInc.com](http://www.NautilusInc.com), 5415 Centerpoint Parkway, Groveport, OH 43125 U.S.A. - Customer Service: North America (800) 605-3369, [csnls@nautilus.com](mailto:csnls@nautilus.com) | outside U.S. [www.nautilusinternational.com](http://www.nautilusinternational.com) | Printed in China | © 2019 Nautilus, Inc. | Schwinn and the Schwinn logo are trademarks owned or licensed by Nautilus, Inc., registered or otherwise protected by common law in the United States and other nations. | **ORIGINAL DOCUMENT - ENGLISH VERSION ONLY**

**Important Safety Instructions - Before servicing or using this equipment, obey the following warnings:**

**!** This icon means a potentially hazardous situation which, if not avoided, could result in death or serious injury. Read and understand all Warnings on this machine.

**! DANGER** To reduce the risk of electrical shock or unsupervised usage of the equipment, always unplug the power cord from the wall outlet and wait 5 minutes before cleaning, maintaining or repairing this machine. Place the power cord in a secure location.

- Read and understand the Part Replacement Procedure before working on the machine. Failure to obey the instructions and safety warnings could cause injury to the service technician or bystanders.
- Keep bystanders, children and pets away from the product being serviced at all times.
- Make sure that the repair is done in an appropriate work space away from foot traffic and exposure to bystanders.
- Disconnect all power and allow to sit for 5 minutes before you service this machine.
- Some components of the equipment can be heavy or awkward. Enlist the service of a second person when you do maintenance steps involving these components. Do not try to do heavy or awkward steps on your own.
- If replacement parts are necessary, use only genuine Nautilus replacement parts and hardware. Failure to use genuine replacement parts can cause a risk to users, keep the machine from operating correctly and will void the warranty.
- Be sure that all warning stickers and instructional placards applied to the product stay present and in good condition when doing maintenance or replacing components. If at any time the Warning labels become loose, unreadable or dislodged, replace the labels. If purchased in US/Canada, contact Customer Service for replacement labels. If purchased outside US/Canada, contact your local distributor for them.
- Do not try to change the design or functionality of the machine being serviced as this can adversely effect user safety and will void the warranty.
- Do not use the machine until all shrouds, instructions, warning labels and correct functionality have been verified and tested for correct performance.

**• SAVE THESE INSTRUCTIONS.**

**Tools Required (not included)**

#2 Phillips screwdriver

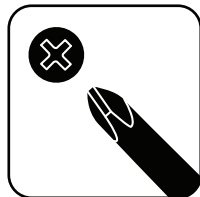

16mm wrench  
(2) 17mm wrenches

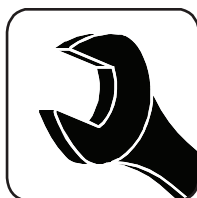

# ⚠ DANGER

To reduce the risk of electrical shock or unsupervised usage of the equipment, always unplug the power cord from the wall outlet and wait 5 minutes before cleaning, maintaining or repairing this machine. Place the power cord in a secure location.

1. Unplug the power cord from the machine and wait 5 minutes. Place the power cord in a secure location.

2. Using a #2 Phillips screwdriver remove the 4 indicated screws from the Motor Cover.



3. Using the support bar found below the rear of the walking belt, lift the walking deck fully upward and engage the hydraulic lift. Be sure that the hydraulic lift is correctly locked in place. You will hear an audible click when the hydraulic lift shifts into the locked position.

**⚠ Use proper safety precautions and lifting techniques. Bend your knees and elbows, keep your back straight and pull up equally with both arms. Straighten your legs to lift. Make sure that your own physical strength is capable of lifting the walking deck until it engages the locking mechanism. Use a second person if necessary.**

**Do not use the walking belt or rear roller to lift the treadmill. These parts do not lock in place and can abruptly move. Injury to you or damage to the machine can occur.**

4. Make sure that the locking mechanism is engaged. Carefully pull back on the walking deck and make sure that it does not move. When you do this, keep clear of movement path in case the treadmill lock is not properly engaged.

**⚠ Do not lean against the treadmill when it is folded. Do not put items on it that could cause it to become unstable or fall.**





5. Using a #2 Phillips screwdriver remove the 2 indicated screws from the Motor Cover and remove it.



6. Remove the connectors for the Incline Motor Potentiometer and the Incline Motor from the Motor Control Board after noting their locations.

**Note:** See detailed diagram and image on the following page to assist. Be sure to note where all cables attach for re-assembly.

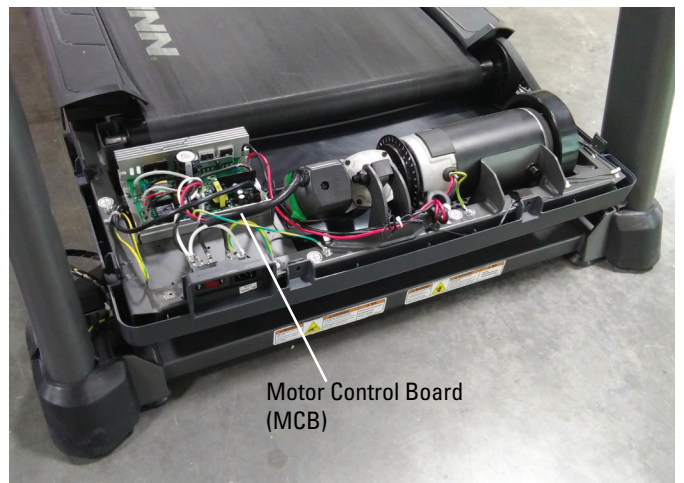

7. Make sure that there is safe clearance around, on and above the treadmill to one side. Tilt the machine onto the side being sure not to grasp the Console.

**!** A second person is required to assist with the tilting of the machine. Do not tilt the machine unless the walking deck is in the folded, locked position. Be sure there is adequate clearance for the raised deck. Some components of the equipment can be heavy or awkward. Enlist the service of a second person when you do maintenance steps involving these components. Do not try to do heavy or awkward steps on your own.



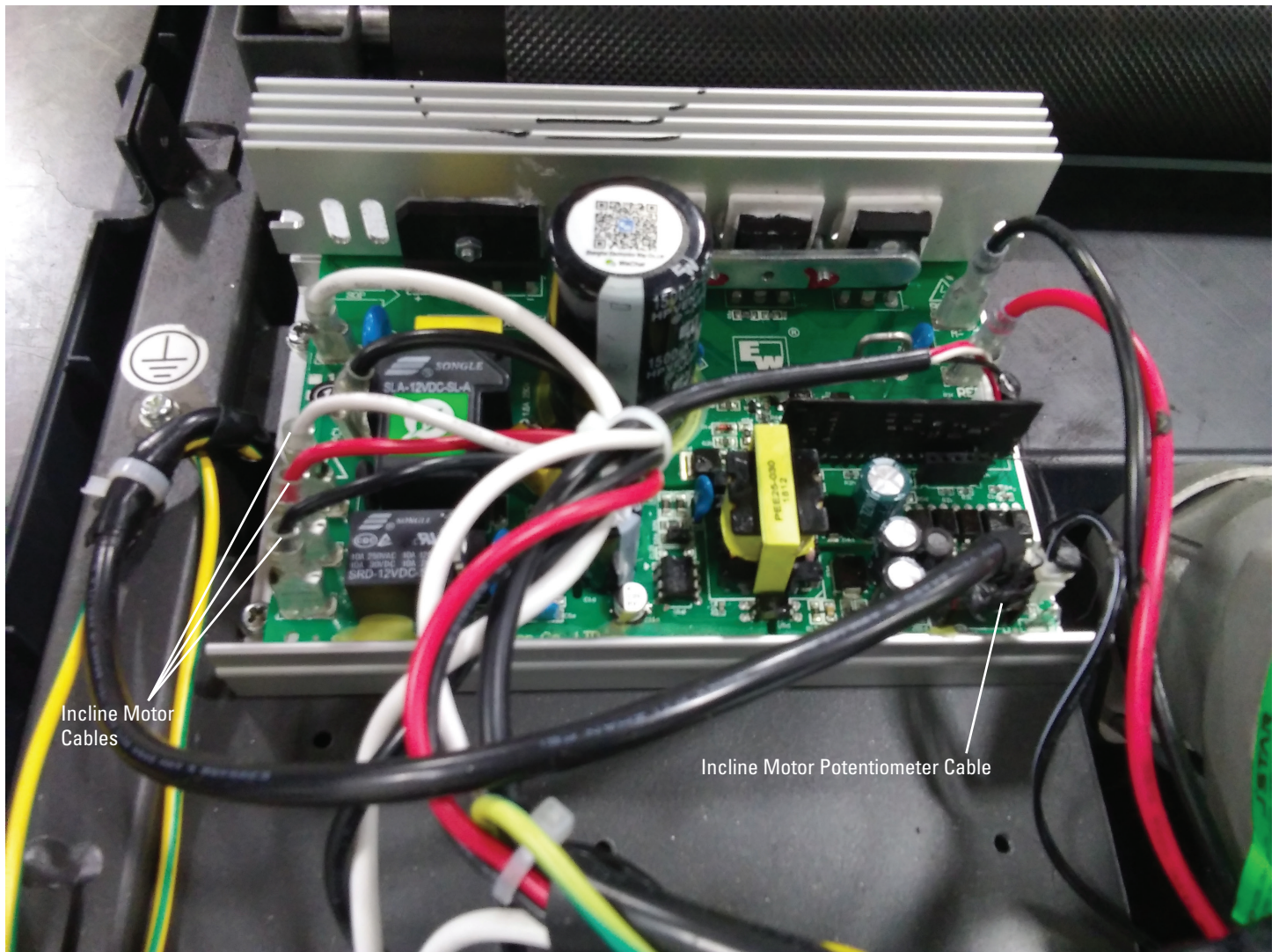
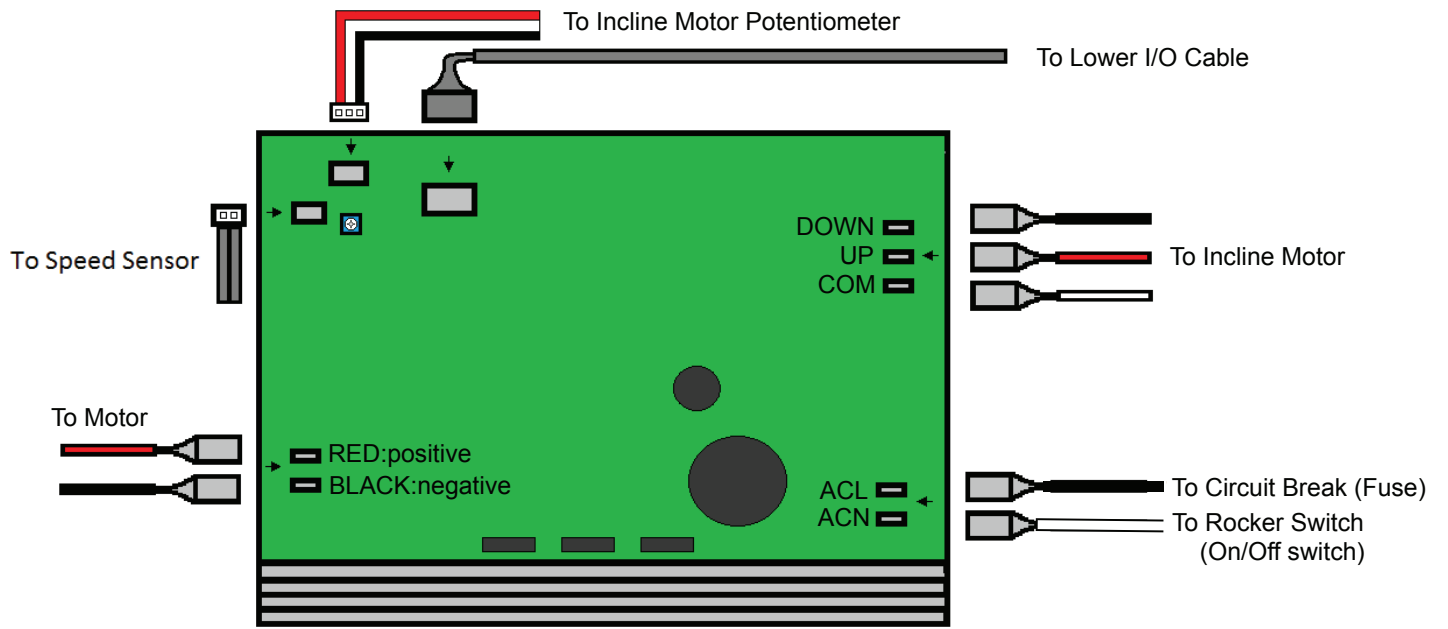



8. Using two 17mm wrenches, remove the hardware from the Incline Motor Assembly.

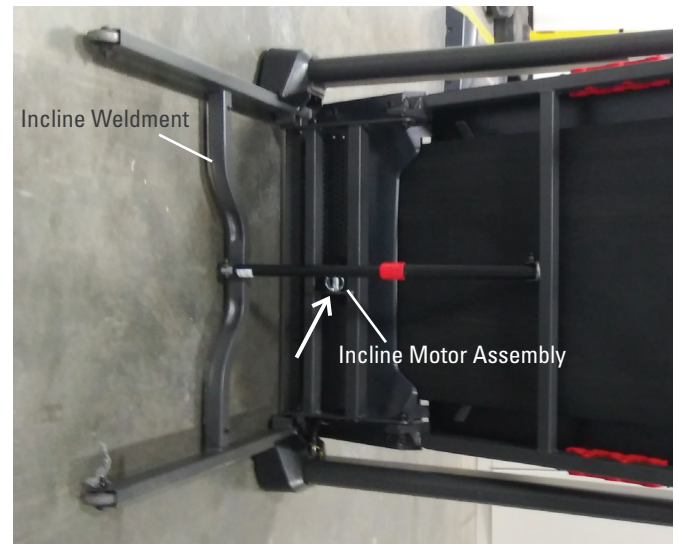

9. Using a 16mm and a 17mm wrench in the Motor Compartment, remove the hardware from the Incline Motor Assembly. Remove the Incline Motor Assembly noting how it extends from the Motor Compartment through to the Incline Weldment.

10. Installation of the Incline Motor Assembly is the reverse procedure.

**Note:** Be sure to attach the cables to the proper locations on the Motor Control Board. Do not pinch or cut the cables.

11. Make sure that there is safe clearance beside the treadmill to one side. Make sure there is sufficient space to tilt the machine back upright.

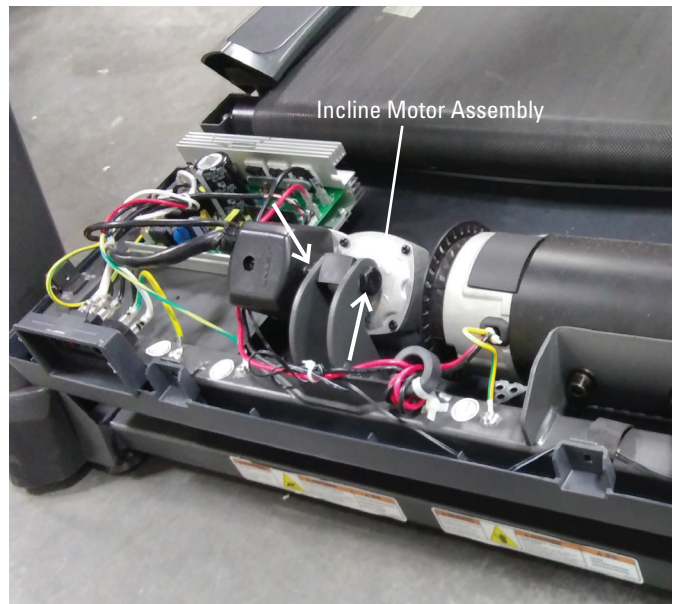

**!** This step requires two people. Be sure there is adequate clearance for the raised deck. Some components of the equipment can be heavy or awkward. Enlist the service of a second person when you do maintenance steps involving these components. Do not try to do heavy or awkward steps on your own.

12. Make sure there is sufficient space to lower the walking deck.

**!** Keep a minimum clearance behind the machine of 79" (2 m) and 24" (0.6 m) on each side. This is the recommended safe distance for access, movement and emergency dismounts from the machine.

13. Make sure there is no object on or around the treadmill to spill or cause blockage from the fully unfolded position.

14. Slightly push the walking deck forward toward the console. With your foot lightly push the top part of the hydraulic lift forward until the locking tube releases and you can pull the walking deck away from the console. Hold up the rear of the walking deck, and move to the side of the machine.



**⚠ Keep clear of the movement path of the walking deck.**

15. The hydraulic lift is set up to drop gradually. Hold onto the walking deck until approximately 2/3 of the movement down. Lower the weight with your legs. Be aware that the walking deck can possibly drop quickly in the last part of the movement.

16. Re-install all remaining parts that were removed in reverse order.

17. Attach the power cord and turn on the Treadmill by flipping the power switch to ON.

18. Stand next to the machine where the Console can easily be reached.

**⚠ Be sure the area around the Treadmill is clear of all bystanders, children and pets. Be sure there is nothing on or under the Walking Belt, or near the Treadmill.**

19. Push and hold down the Pause/Stop and Enter buttons until machine enters engineering mode.

20. Push the Start button 8 times.

21. The calibration procedure will begin by automatically moving the Walking Belt and adjusting the incline of the Walking Deck for about a minute. Then the console will flash and beep.

**⚠ Be sure not to touch or allow anyone else to touch the machine while calibration is occurring.**

22. The calibration procedure is now complete.



23. Final Inspection

Inspect your machine to ensure that all hardware is tight and components are properly assembled.

**⚠ Do not use until the machine has been fully assembled and inspected for correct performance in accordance with the Owner's Manual.**

**NOTICE:** This document provides instructions for the replacement of the Input/Output (I/O) Cable on the Schwinn™ 810 / 510T machine.

If you need assistance, please contact Customer Service (if purchased in US/Canada) or your local distributor (if purchased outside US/Canada). To find your local distributor, go to: [www.nautilusinternational.com](http://www.nautilusinternational.com)

**!** This icon means a potentially hazardous situation which, if not avoided, could result in death or serious injury. Read and understand all Warnings on this machine.

Nautilus, Inc., [www.NautilusInc.com](http://www.NautilusInc.com), 5415 Centerpoint Parkway, Groveport, OH 43125 U.S.A. - Customer Service: North America (800) 605-3369, [csnls@nautilus.com](mailto:csnls@nautilus.com) | outside U.S. [www.nautilusinternational.com](http://www.nautilusinternational.com) | Printed in China | © 2019 Nautilus, Inc. | Schwinn and the Schwinn logo are trademarks owned or licensed by Nautilus, Inc., registered or otherwise protected by common law in the United States and other nations. | **ORIGINAL DOCUMENT - ENGLISH VERSION ONLY**

**Important Safety Instructions - Before servicing or using this equipment, obey the following warnings:**

**!** This icon means a potentially hazardous situation which, if not avoided, could result in death or serious injury. Read and understand all Warnings on this machine.

**! DANGER** To reduce the risk of electrical shock or unsupervised usage of the equipment, always unplug the power cord from the wall outlet and wait 5 minutes before cleaning, maintaining or repairing this machine. Place the power cord in a secure location.

- Read and understand the Part Replacement Procedure before working on the machine. Failure to obey the instructions and safety warnings could cause injury to the service technician or bystanders.
- Keep bystanders, children and pets away from the product being serviced at all times.
- Make sure that the repair is done in an appropriate work space away from foot traffic and exposure to bystanders.
- Disconnect all power and allow to sit for 5 minutes before you service this machine.
- Some components of the equipment can be heavy or awkward. Enlist the service of a second person when you do maintenance steps involving these components. Do not try to do heavy or awkward steps on your own.
- If replacement parts are necessary, use only genuine Nautilus replacement parts and hardware. Failure to use genuine replacement parts can cause a risk to users, keep the machine from operating correctly and will void the warranty.
- Be sure that all warning stickers and instructional placards applied to the product stay present and in good condition when doing maintenance or replacing components. If at any time the Warning labels become loose, unreadable or dislodged, replace the labels. If purchased in US/Canada, contact Customer Service for replacement labels. If purchased outside US/Canada, contact your local distributor for them.
- Do not try to change the design or functionality of the machine being serviced as this can adversely effect user safety and will void the warranty.
- Do not use the machine until all shrouds, instructions, warning labels and correct functionality have been verified and tested for correct performance.

**• SAVE THESE INSTRUCTIONS.**

**Tools Required (not included)**

#2 Phillips screwdriver

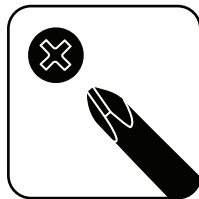

6mm hex wrench





# ⚠ DANGER

To reduce the risk of electrical shock or unsupervised usage of the equipment, always unplug the power cord from the wall outlet and wait 5 minutes before cleaning, maintaining or repairing this machine. Place the power cord in a secure location.

1. Unplug the power cord from the machine and wait 5 minutes. Place the power cord in a secure location.

2. Using a #2 Phillips screwdriver, remove the Handlebar Shrouds from the machine.

*NOTICE:* \* To assist with re-assembly, install the Inner Handlebar Shrouds first.

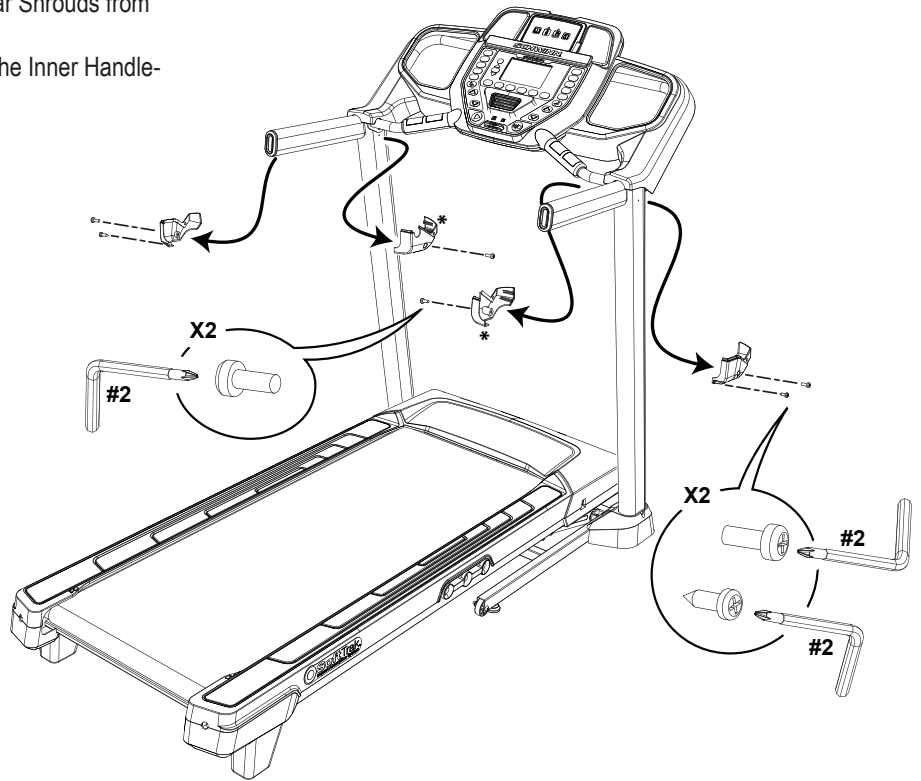

3. Using a 6mm hex wrench, remove the indicated hardware from the machine. Then safely lift the right side of the Console Assembly just enough to expose the Cable Connections. Disconnect the Cables and remove the Console Assembly.

**Note:** This step may require two people.

*NOTICE:* \* To assist with re-assembly, start this hardware first.

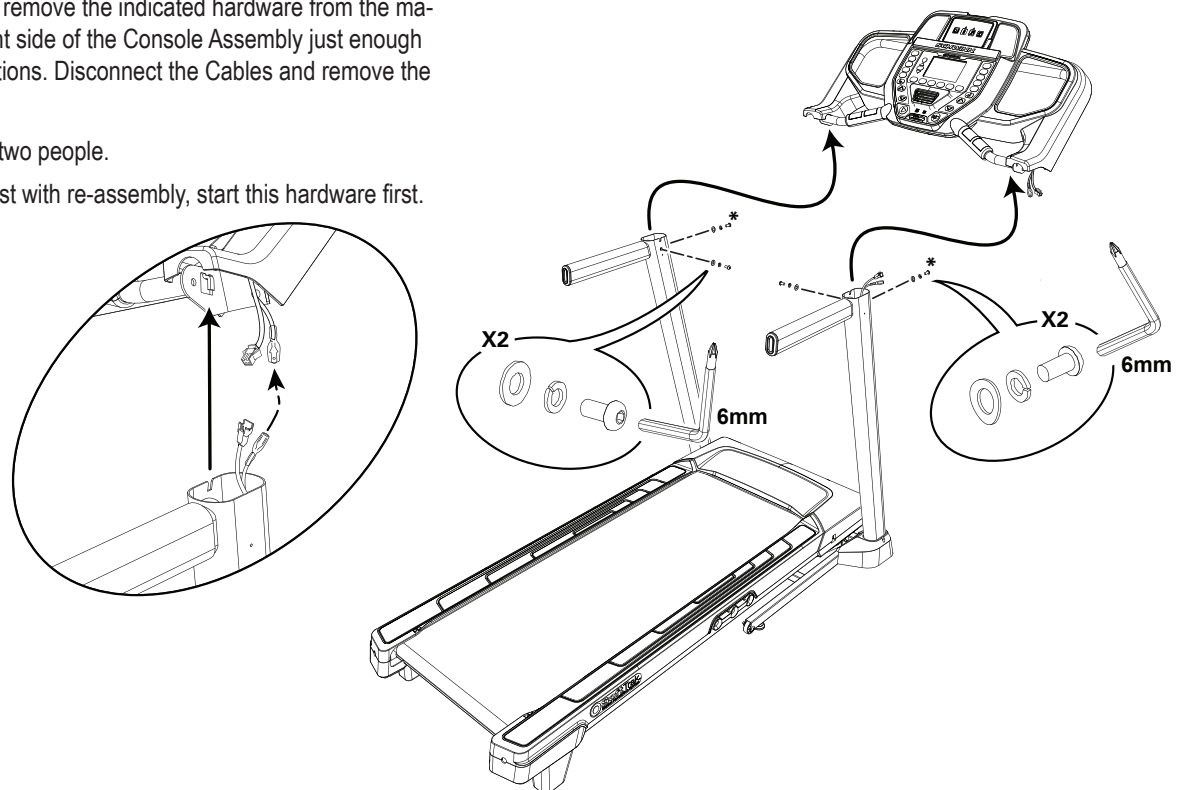

4. Using a #2 Phillips screwdriver remove the 4 indicated screws from the Motor Cover.



5. Make sure that there is safe clearance around, on and above the treadmill. Make sure there is no object to spill or cause blockage from the fully folded position.

**!** Be sure there is adequate height clearance for the raised deck.

6. Using the support bar found below the rear of the walking belt, lift the walking deck fully upward and engage the hydraulic lift. Be sure that the hydraulic lift is correctly locked in place. You will hear an audible click when the hydraulic lift shifts into the locked position.

**!** Use proper safety precautions and lifting techniques. Bend your knees and elbows, keep your back straight and pull up equally with both arms. Straighten your legs to lift. Make sure that your own physical strength is capable of lifting the walking deck until it engages the locking mechanism. Use a second person if necessary.

Do not use the walking belt or rear roller to lift the treadmill. These parts do not lock in place and can abruptly move. Injury to you or damage to the machine can occur.

7. Make sure that the locking mechanism is engaged. Carefully pull back on the walking deck and make sure that it does not move. When you do this, keep clear of movement path in case the treadmill lock is not properly engaged.

**!** Do not lean against the treadmill when it is folded. Do not put items on it that could cause it to become unstable or fall.



8. Using a #2 Phillips screwdriver remove the 2 indicated screws from the Motor Cover and remove it.



9. Connect the new I/O Cable to the old I/O Cable using a piece of wire or string. Be sure that the ends of the Cables that you are connecting do not match.

**Note:** Do not pinch or cut the cables.

10. Gently pull the old I/O Cable toward the MCB, routing the new I/O Cable through the Right Upright to the MCB.

**Note:** Be sure the cable does not crimp when being routed.

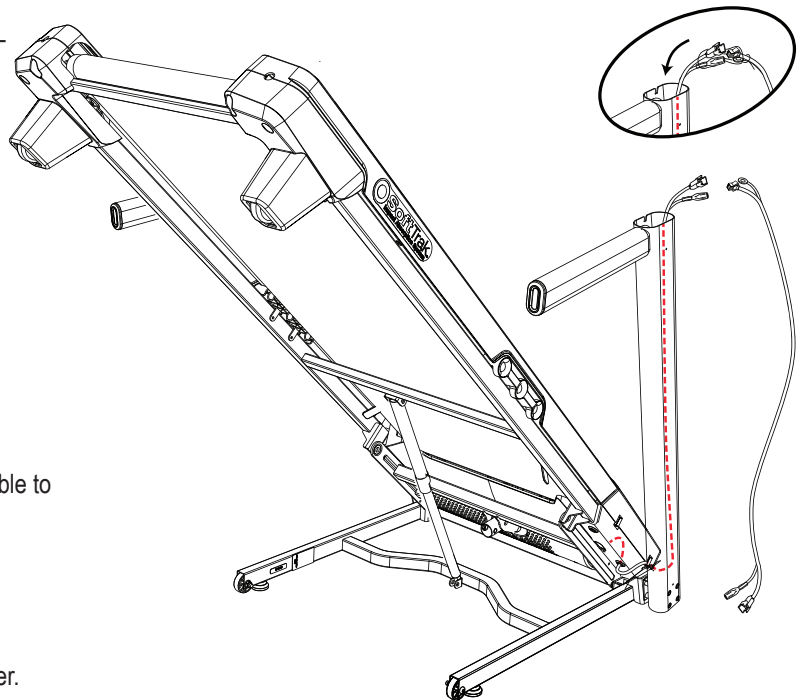

11. Disconnect the old I/O Cable, and dispose of it appropriately.

12. Connect the new I/O Cable to the MCB, and the Grounding Cable to the Frame Assembly.

13. Re-install all remaining parts that were removed in reverse order.

14. Make sure there is sufficient space to lower the walking deck.

**⚠** Keep a minimum clearance behind the machine of 79" (2 m) and 19.7" (0.5 m) on each side. This is the recommended safe distance for access, movement and emergency dismounts from the machine.

15. Make sure there is no object on or around the treadmill to spill or cause blockage from the fully unfolded position.

16. Slightly push the walking deck forward toward the console. With your foot lightly push the top part of the hydraulic lift forward until the locking tube releases and you can pull the walking deck away from the console. Hold up the rear of the walking deck, and move to the side of the machine.

**⚠** Keep clear of the movement path of the walking deck.





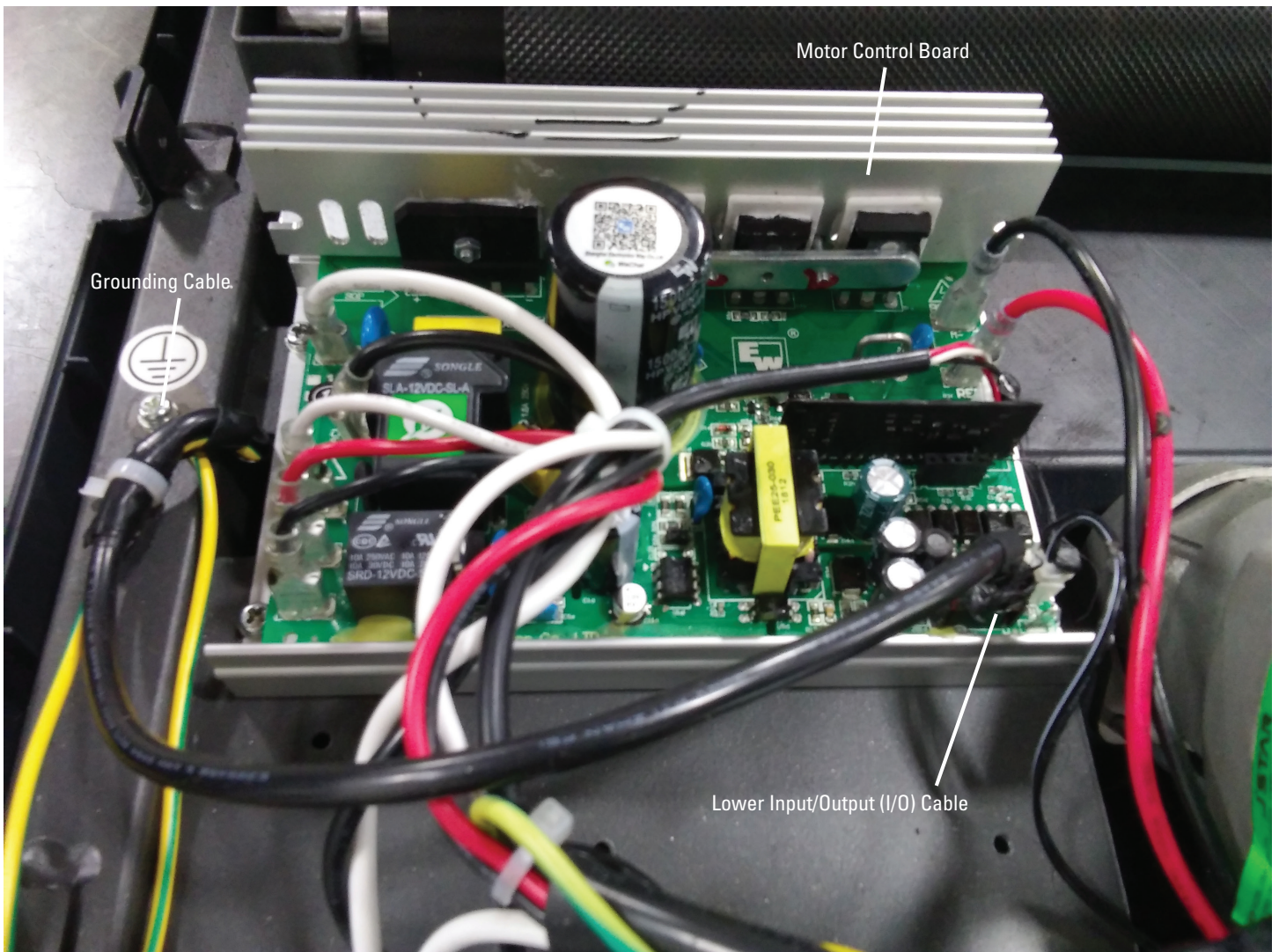
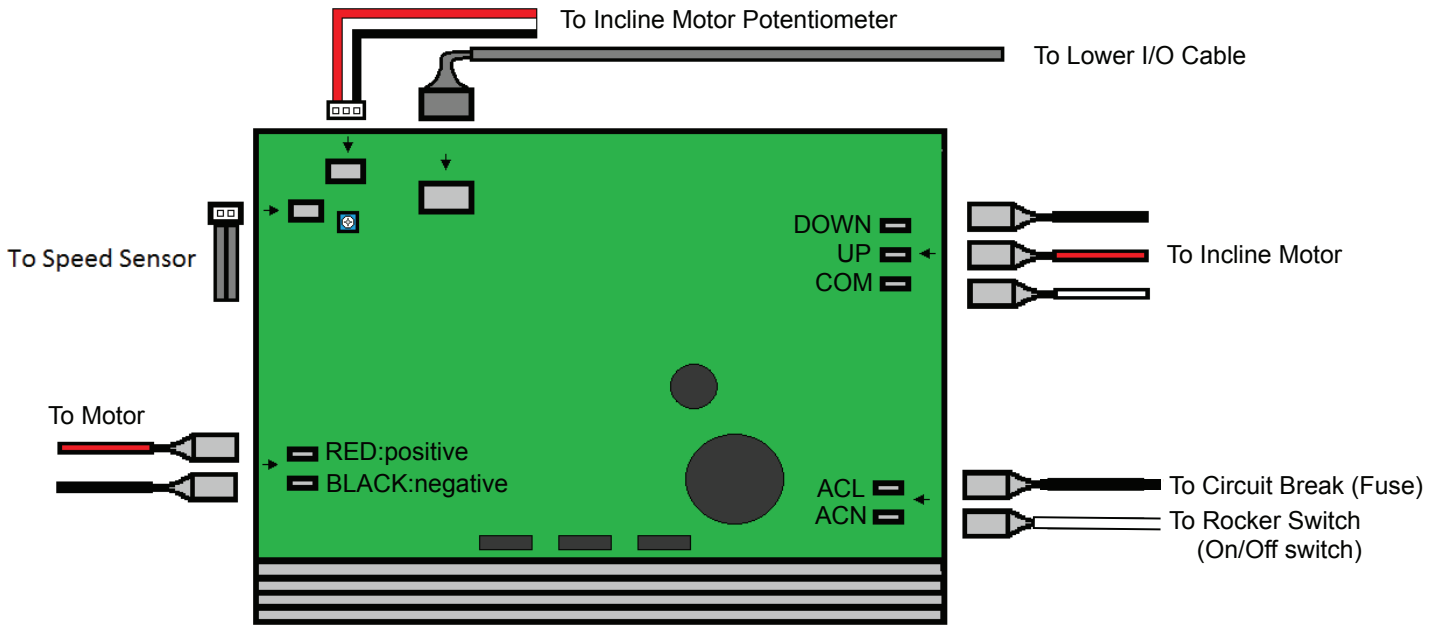

17. The hydraulic lift is set up to drop gradually. Hold onto the walking deck until approximately 2/3 of the movement down. Lower the weight with your legs. Be aware that the walking deck can possibly drop quickly in the last part of the movement.

18. Final Inspection

Inspect your machine to ensure that all hardware is tight and components are properly assembled.



**Do not use until the machine has been fully assembled and inspected for correct performance in accordance with the Owner's Manual.**



**NOTICE:** This document provides instructions for the replacement of the Lift Shock on the Schwinn™ 810 / 510T machine.

If you need assistance, please contact Customer Service (if purchased in US/Canada) or your local distributor (if purchased outside US/Canada). To find your local distributor, go to: [www.nautilusinternational.com](http://www.nautilusinternational.com)

**!** This icon means a potentially hazardous situation which, if not avoided, could result in death or serious injury. Read and understand all Warnings on this machine.

Nautilus, Inc., [www.NautilusInc.com](http://www.NautilusInc.com), 5415 Centerpoint Parkway, Groveport, OH 43125 U.S.A. - Customer Service: North America (800) 605-3369, [csnls@nautilus.com](mailto:csnls@nautilus.com) | outside U.S. [www.nautilusinternational.com](http://www.nautilusinternational.com) | Printed in China | © 2019 Nautilus, Inc. | Schwinn and the Schwinn logo are trademarks owned or licensed by Nautilus, Inc., registered or otherwise protected by common law in the United States and other nations. | **ORIGINAL DOCUMENT - ENGLISH VERSION ONLY**

### Important Safety Instructions - Before servicing or using this equipment, obey the following warnings:

**!** This icon means a potentially hazardous situation which, if not avoided, could result in death or serious injury. Read and understand all Warnings on this machine.

**! DANGER** To reduce the risk of electrical shock or unsupervised usage of the equipment, always unplug the power cord from the wall outlet and wait 5 minutes before cleaning, maintaining or repairing this machine. Place the power cord in a secure location.

- Read and understand the Part Replacement Procedure before working on the machine. Failure to obey the instructions and safety warnings could cause injury to the service technician or bystanders.
- Keep bystanders, children and pets away from the product being serviced at all times.
- Make sure that the repair is done in an appropriate work space away from foot traffic and exposure to bystanders.
- Disconnect all power and allow to sit for 5 minutes before you service this machine.
- Some components of the equipment can be heavy or awkward. Enlist the service of a second person when you do maintenance steps involving these components. Do not try to do heavy or awkward steps on your own.
- If replacement parts are necessary, use only genuine Nautilus replacement parts and hardware. Failure to use genuine replacement parts can cause a risk to users, keep the machine from operating correctly and will void the warranty.
- Be sure that all warning stickers and instructional placards applied to the product stay present and in good condition when doing maintenance or replacing components. If at any time the Warning labels become loose, unreadable or dislodged, replace the labels. If purchased in US/Canada, contact Customer Service for replacement labels. If purchased outside US/Canada, contact your local distributor for them.
- Do not try to change the design or functionality of the machine being serviced as this can adversely effect user safety and will void the warranty.
- Do not use the machine until all shrouds, instructions, warning labels and correct functionality have been verified and tested for correct performance.

### • SAVE THESE INSTRUCTIONS.

#### Tools Required (not included)

13mm wrench



6mm hex wrench



# **⚠ DANGER**

To reduce the risk of electrical shock or unsupervised usage of the equipment, always unplug the power cord from the wall outlet and wait 5 minutes before cleaning, maintaining or repairing this machine. Place the power cord in a secure location.

1. Unplug the power cord from the machine and wait 5 minutes. Place the power cord in a secure location.

2. Make sure that there is safe clearance around, on and above the treadmill. Make sure there is no object to spill or cause blockage from the fully folded position.

**⚠ Be sure there is adequate height clearance for the raised deck.**

3. Using the support bar found below the rear of the walking belt, lift the walking deck fully upward and engage the hydraulic lift. Be sure that the hydraulic lift is correctly locked in place.

**⚠ Use proper safety precautions and lifting techniques. Bend your knees and elbows, keep your back straight and pull up equally with both arms. Straighten your legs to lift. Make sure that your own physical strength is capable of lifting the walking deck until it engages the locking mechanism. Use a second person if necessary.**

**Do not use the walking belt or rear roller to lift the treadmill. These parts do not lock in place and can abruptly move. Injury to you or damage to the machine can occur.**

4. Make sure that the locking mechanism is engaged. Carefully pull back on the walking deck and make sure that it does not move. When you do this, keep clear of movement path in case the treadmill lock is not properly engaged.

**⚠ Do not lean against the treadmill when it is folded. Do not put items on it that could cause it to become unstable or fall.**



5. Make sure that there is safe clearance around, above, and to one side of the treadmill. Tilt the machine onto the side being sure not to grasp the Console.

**!** A second person is required to assist with the tilting of the machine. Do not tilt the machine unless the walking deck is in the folded, locked position. Be sure there is adequate clearance for the raised deck. Some components of the equipment can be heavy or awkward. Enlist the service of a second person when you do maintenance steps involving these components. Do not try to do heavy or awkward steps on your own.



**! DANGER** The following images show the machine upright, and not fully resting on its side. The machine must be on its side to safely complete the following steps.

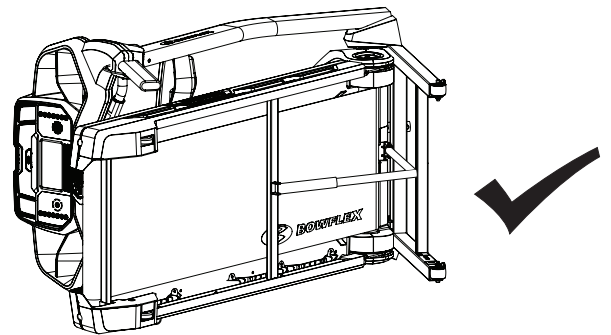

6. Using a 13mm wrench and a 6mm hex wrench, remove the indicated hardware (with ovals) from the Lift Shock Assembly.

**!** Be aware that when the Lift Shock is released from the Frame Assembly, the Lift Shock and Base Frame Weldment may abruptly move. Be sure to keep clear of any potential pinch opportunities from this motion.

7. Remove the old Lift Shock and replace with the new Lift Shock.

8. Installation of the remaining parts is the reverse procedure.



9. Make sure there is sufficient space to tilt the machine back upright and that the area is clear.

**!** This step requires two people. Be sure there is adequate clearance for the raised deck. Some components of the equipment can be heavy or awkward. Enlist the service of a second person when you do maintenance steps involving these components. Do not try to do heavy or awkward steps on your own.

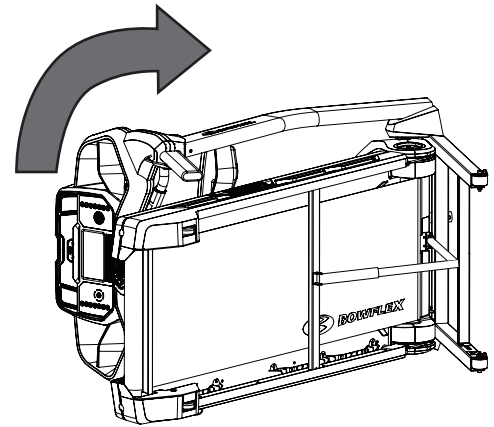

10. Make sure there is sufficient space to lower the walking deck.

**!** Keep a minimum clearance behind the machine of 79" (2 m) and 19.7" (0.5 m) on each side. This is the recommended safe distance for access, movement and emergency dismounts from the machine.

11. Make sure there is no object on or around the treadmill to spill or cause blockage from the fully unfolded position.

12. Slightly push the walking deck forward toward the console. With your foot lightly push the top part of the hydraulic lift forward until the locking tube releases and you can pull the walking deck away from the console. Hold up the rear of the walking deck, and move to the side of the machine.

**!** Keep clear of the movement path of the walking deck.

13. The hydraulic lift is set up to drop gradually. Hold onto the walking deck until approximately 2/3 of the movement down. Lower the weight with your legs. Be aware that the walking deck can possibly drop quickly in the last part of the movement.



14. Final Inspection

Inspect your machine to ensure that all hardware is tight and components are properly assembled.

**!** Do not use until the machine has been fully assembled and inspected for correct performance in accordance with the Owner's Manual.



**NOTICE:** This document provides instructions for the replacement of the Motor on the Schwinn™ 810 / 510T machine.

If you need assistance, please contact Customer Service (if purchased in US/Canada) or your local distributor (if purchased outside US/Canada). To find your local distributor, go to: [www.nautilusinternational.com](http://www.nautilusinternational.com)

**!** This icon means a potentially hazardous situation which, if not avoided, could result in death or serious injury. Read and understand all Warnings on this machine.

Nautilus, Inc., [www.NautilusInc.com](http://www.NautilusInc.com), 5415 Centerpoint Parkway, Groveport, OH 43125 U.S.A. - Customer Service: North America (800) 605-3369, [csnls@nautilus.com](mailto:csnls@nautilus.com) | outside U.S. [www.nautilusinternational.com](http://www.nautilusinternational.com) | Printed in China | © 2019 Nautilus, Inc. | Schwinn and the Schwinn logo are trademarks owned or licensed by Nautilus, Inc., registered or otherwise protected by common law in the United States and other nations. | **ORIGINAL DOCUMENT - ENGLISH VERSION ONLY**

**Important Safety Instructions - Before servicing or using this equipment, obey the following warnings:**

**!** This icon means a potentially hazardous situation which, if not avoided, could result in death or serious injury. Read and understand all Warnings on this machine.

**! DANGER** To reduce the risk of electrical shock or unsupervised usage of the equipment, always unplug the power cord from the wall outlet and wait 5 minutes before cleaning, maintaining or repairing this machine. Place the power cord in a secure location.

- Read and understand the Part Replacement Procedure before working on the machine. Failure to obey the instructions and safety warnings could cause injury to the service technician or bystanders.
- Keep bystanders, children and pets away from the product being serviced at all times.
- Make sure that the repair is done in an appropriate work space away from foot traffic and exposure to bystanders.
- Disconnect all power and allow to sit for 5 minutes before you service this machine.
- Some components of the equipment can be heavy or awkward. Enlist the service of a second person when you do maintenance steps involving these components. Do not try to do heavy or awkward steps on your own.
- If replacement parts are necessary, use only genuine Nautilus replacement parts and hardware. Failure to use genuine replacement parts can cause a risk to users, keep the machine from operating correctly and will void the warranty.
- Be sure that all warning stickers and instructional placards applied to the product stay present and in good condition when doing maintenance or replacing components. If at any time the Warning labels become loose, unreadable or dislodged, replace the labels. If purchased in US/Canada, contact Customer Service for replacement labels. If purchased outside US/Canada, contact your local distributor for them.
- Do not try to change the design or functionality of the machine being serviced as this can adversely effect user safety and will void the warranty.
- Do not use the machine until all shrouds, instructions, warning labels and correct functionality have been verified and tested for correct performance.

**• SAVE THESE INSTRUCTIONS.**

**Tools Required (not included)**

#2 Phillips screwdriver

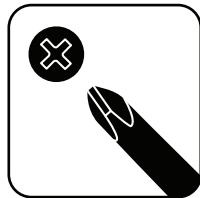

8300 Silicone Spray or Lube-N-Walk® Treadmill Lubrication Kit

6mm hex wrench



13mm wrench





# ⚠ DANGER

To reduce the risk of electrical shock or unsupervised usage of the equipment, always unplug the power cord from the wall outlet and wait 5 minutes before cleaning, maintaining or repairing this machine. Place the power cord in a secure location.

1. Unplug the power cord from the machine and wait 5 minutes. Place the power cord in a secure location.

2. Using a 6mm hex wrench, loosen the Walking Belt with the Adjustment Bolts found on both Rear Roller Covers. Loosen the Adjustment Bolts only until the Walking Belt slides past the Rollers freely. Do not loosen the Adjustment Bolts too much or the Rear Roller may detach.

**Note:** Be sure to record the number of turns of the Adjustment Bolts it takes to loosen the Walking Belt. This will assist with reassembly.

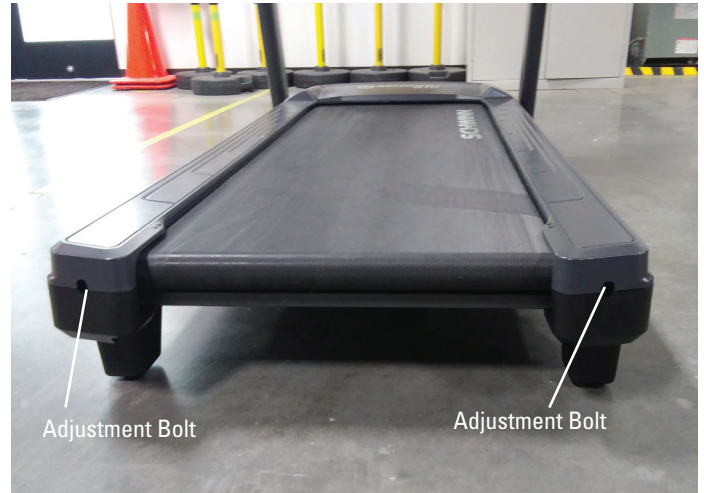

3. Using a #2 Phillips screwdriver remove the 4 indicated screws from the Motor Cover.



4. Make sure that there is safe clearance around, on and above the treadmill. Make sure there is no object to spill or cause blockage from the fully folded position.

**⚠ Be sure there is adequate height clearance for the raised deck.**

5. Using the support bar found below the rear of the walking belt, lift the walking deck fully upward and engage the hydraulic lift. Be sure that the hydraulic lift is correctly locked in place. You will hear an audible click when the hydraulic lift shifts into the locked position.

**⚠ Use proper safety precautions and lifting techniques. Bend your knees and elbows, keep your back straight and pull up equally with both arms. Straighten your legs to lift. Make sure that your own physical strength is capable of lifting the walking deck until it engages the locking mechanism. Use a second person if necessary.**

**Do not use the walking belt or rear roller to lift the treadmill. These parts do not lock in place and can abruptly move. Injury to you or damage to the machine can occur.**



6. Make sure that the locking mechanism is engaged. Carefully pull back on the walking deck and make sure that it does not move. When you do this, keep clear of movement path in case the treadmill lock is not properly engaged.

**!** Do not lean against the treadmill when it is folded. Do not put items on it that could cause it to become unstable or fall.

7. Using a #2 Phillips screwdriver remove the 2 indicated screws from the Motor Cover and remove it.



8. Make sure there is sufficient space to lower the walking deck.

**!** Keep a minimum clearance behind the machine of 79" (2 m) and 19.7" (0.5 m) on each side. This is the recommended safe distance for access, movement and emergency dismounts from the machine.

9. Make sure there is no object on or around the treadmill to spill or cause blockage from the fully unfolded position.

10. Slightly push the walking deck forward toward the console. With your foot lightly push the top part of the hydraulic lift forward until the locking tube releases and you can pull the walking deck away from the console. Hold up the rear of the walking deck, and move to the side of the machine.

**!** Keep clear of the movement path of the walking deck.

11. The hydraulic lift is set up to drop gradually. Hold onto the walking deck until approximately 2/3 of the movement down. Lower the weight with your legs. Be aware that the walking deck can possibly drop quickly in the last part of the movement.



12. Be sure to observe the distance from the Speed Sensor to the Drive Pulley. This distance affects the effectiveness of the Speed Sensor, and can easily be shifted accidentally during replacement procedures.

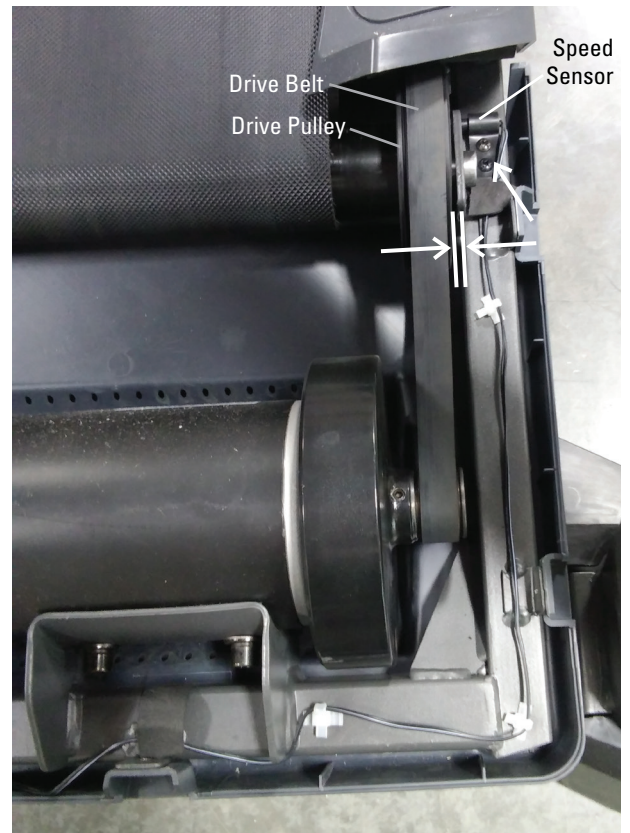

13. Using a 6mm hex wrench, remove the screw (indicated by arrow) from the Front Roller.

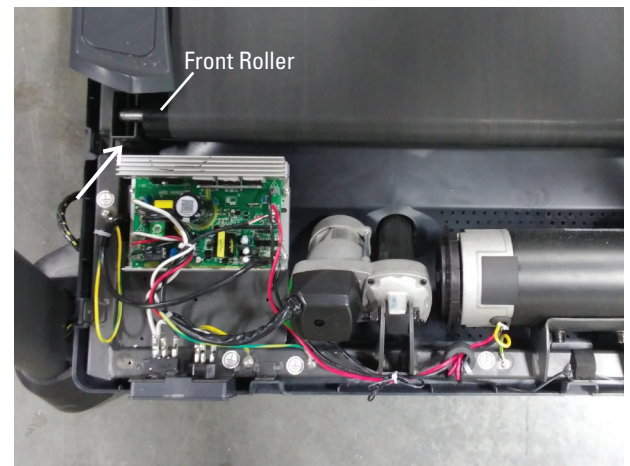



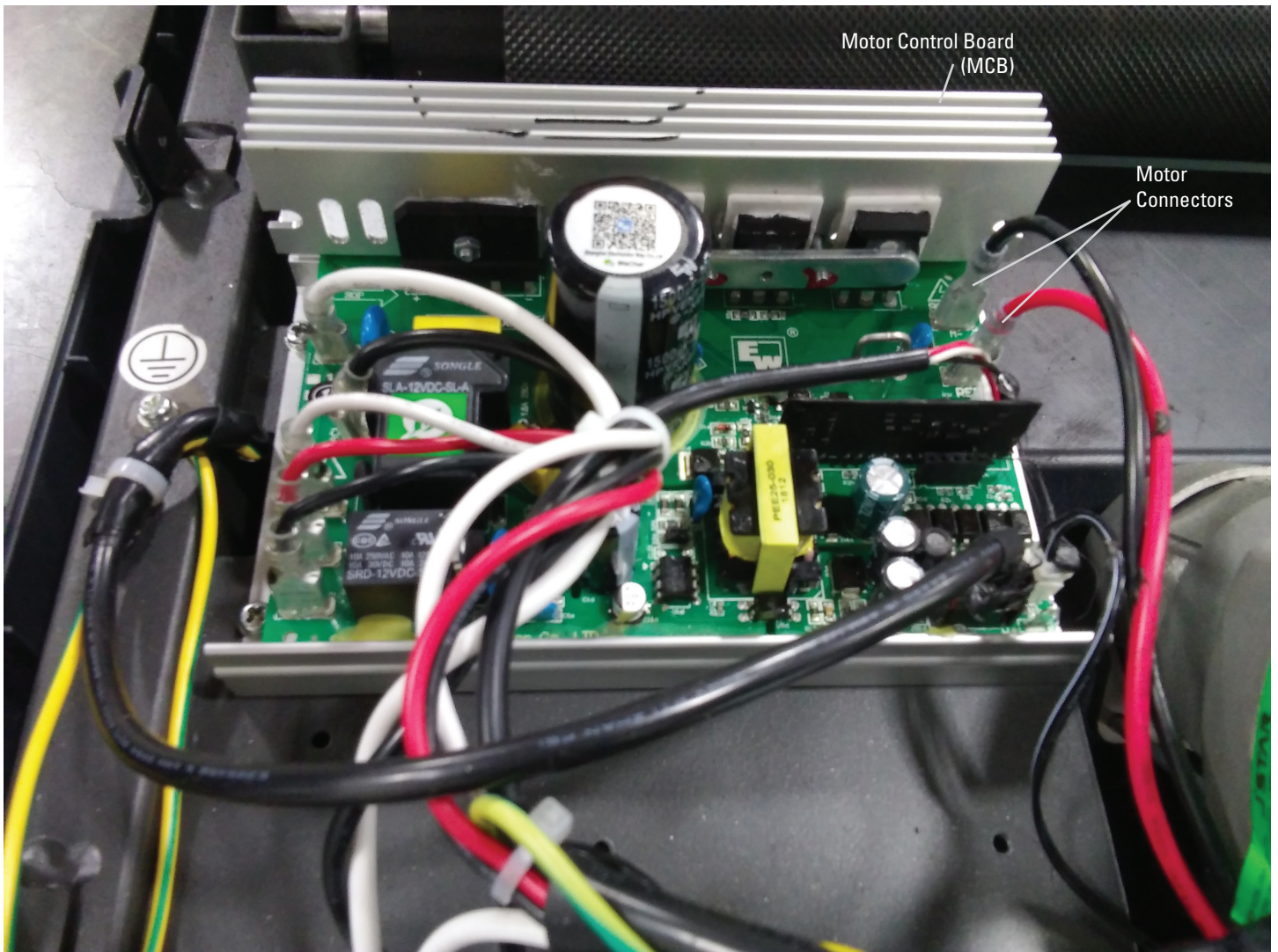
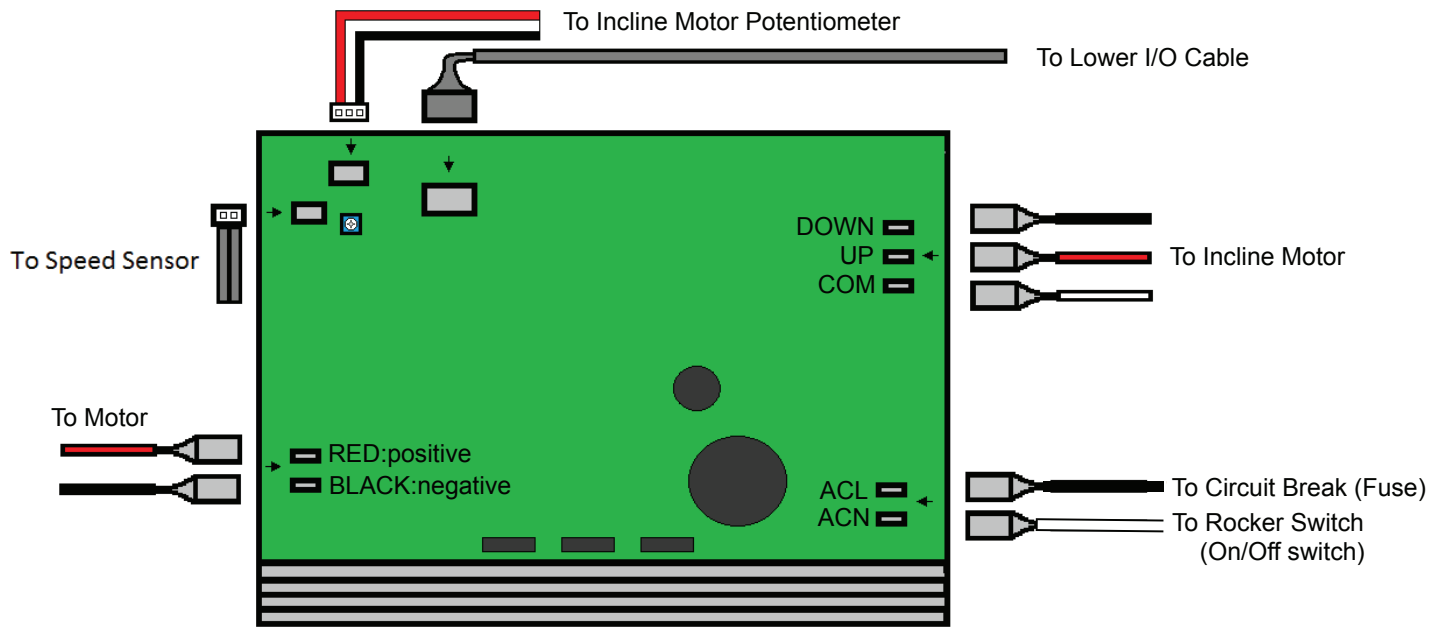

**Note:** Your machine may not match the provided images exactly.

14. Lift and pivot the Front Roller out of the Frame, and slide it out of the Walking Belt. This will free the Drive Belt from the Front Roller.

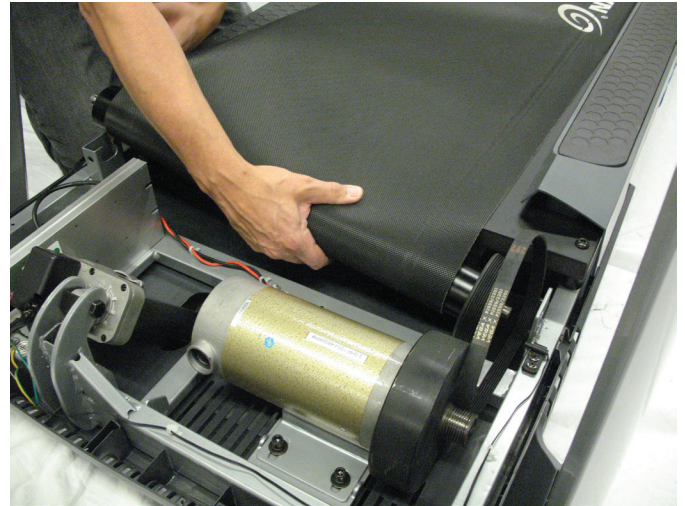

15. Using a #2 Phillips screwdriver, disconnect the Motor Ground Screw from the Frame.

16. Remove the connectors for the Motor from the Motor Control Board after noting their locations.

**Note:** Be sure to note where all cables attach for re-assembly.

17. Using a 6mm hex wrench, remove the indicated screws (by ovals) from the Motor Mount. Remove the Drive Belt from the Motor.

18. Cut the Zip-Tie that secures the Motor Cables.

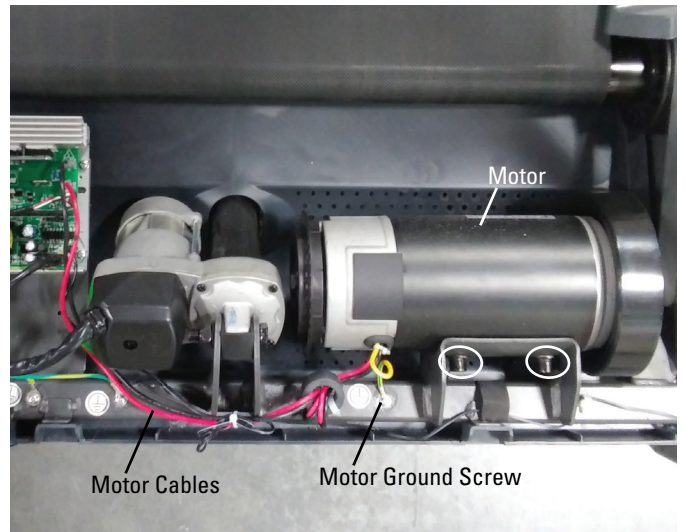

19. Lightly attach the new Motor to the Frame. Be sure to only finger tighten the hardware.

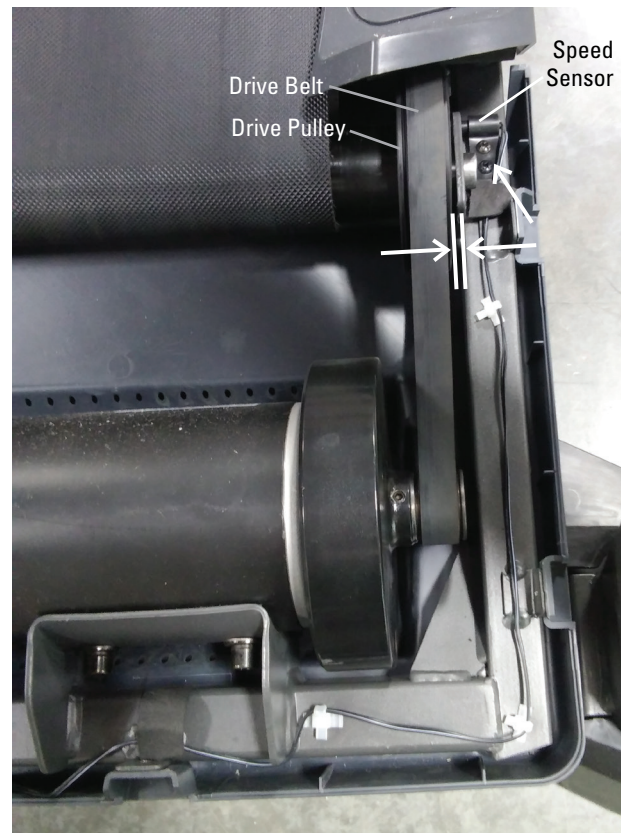



20. Loop the Drive Belt around the Front Roller. Insert the end of the Front Roller with the Drive Pulley into the Frame and pivot the other end into the Bracket.

21. Using a 6mm hex wrench, attach the Front Roller to the Bracket.

**Note:** Tighten the hardware until the Front Roller is centered in the Bracket.

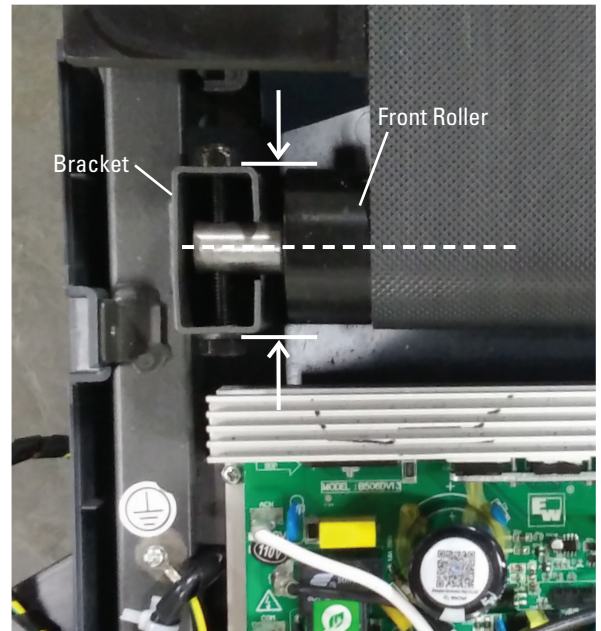

22. Loop the Drive Belt around the Motor Pulley. Start the Drive Belt on the Drive Pulley and roll it in a clockwise motion. Be sure the Belt does not come off of the Motor Pulley.

**⚠ Keep fingers out of any pinch opportunities when turning the Pulleys.**

23. Roll the Drive Pulley clockwise until the Drive Belt is fully installed. Continue to roll the Belt forward while adding side pressure with fingers to align as necessary.

24. Fully tighten the hardware that secures the Motor to the Frame.

25. Inspect the Speed Sensor to see if it has been moved during the procedure. If necessary, adjust it to be the appropriate distance from the Drive Pulley.

26. Re-install all remaining parts that were removed in reverse order.

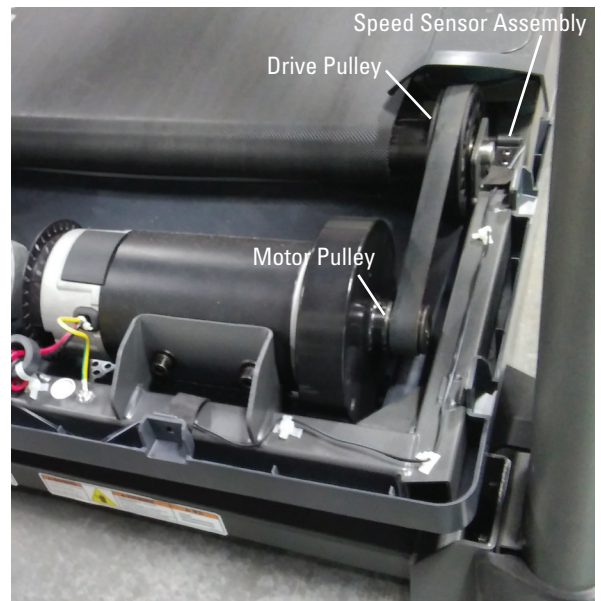

27. Make sure that there is safe clearance around, on and above the treadmill. Make sure there is no object to spill or cause blockage from the fully folded position.

**!** Be sure there is adequate height clearance for the raised deck.

28. Using the support bar found below the rear of the walking belt, lift the walking deck fully upward and engage the hydraulic lift. Be sure that the hydraulic lift is correctly locked in place. You will hear an audible click when the hydraulic lift shifts into the locked position.

**!** Use proper safety precautions and lifting techniques. Bend your knees and elbows, keep your back straight and pull up equally with both arms. Straighten your legs to lift. Make sure that your own physical strength is capable of lifting the walking deck until it engages the locking mechanism. Use a second person if necessary.

**Do not use the walking belt or rear roller to lift the treadmill. These parts do not lock in place and can abruptly move. Injury to you or damage to the machine can occur.**

29. Make sure that the locking mechanism is engaged. Carefully pull back on the walking deck and make sure that it does not move. When you do this, keep clear of movement path in case the treadmill lock is not properly engaged.

**!** Do not lean against the treadmill when it is folded. Do not put items on it that could cause it to become unstable or fall.



30. Inspect the surface material below the Treadmill. If the surface material is difficult to clean or could be damaged by silicone lubricant, place absorbent material (such as cardboard or newspaper) below the length of the Walking Deck.

31. Apply a few drops of lubricant to the inner surface of the belt for the entire width of the belt. A very thin layer of silicone lubricant on the entire deck below the belt is desired.

*NOTICE:* Always use a 100% silicone lubricant. Do not use a degreaser like WD-40® as this could seriously impact performance. We can recommend that you use the following:

- 8300 Silicone Spray, available at most Hardware and Auto Parts stores.
- Lube-N-Walk® Treadmill Lubrication Kit, available from your local specialty fitness dealer or Nautilus, Inc.

32. Manually rotate the belt 1/2 of the length of the belt and apply lubricant again.

33. Make sure there is sufficient space to lower the walking deck.

**!** Keep a minimum clearance behind the machine of 79" (2 m) and 19.7" (0.5 m) on each side. This is the recommended safe distance for access, movement and emergency dismounts from the machine.

34. Make sure there is no object on or around the treadmill to spill or cause blockage from the fully unfolded position.

35. Slightly push the walking deck forward toward the console. With your foot lightly push the top part of the hydraulic lift forward until the locking tube releases and you can pull the walking deck away from the console. Hold up the rear of the walking deck, and move to the side of the machine.

**⚠ Keep clear of the movement path of the walking deck.**

36. The hydraulic lift is set up to drop gradually. Hold onto the walking deck until approximately 2/3 of the movement down. Lower the weight with your legs. Be aware that the walking deck can possibly drop quickly in the last part of the movement.

**⚠ If you used spray lubricant, wait 5 minutes before turning on power to the machine to allow the aerosol to dissipate.**

37. Attach the power cord and turn on the Treadmill by flipping the power switch to ON.

38. Start the belt at the slowest speed and stand well behind the machine. Let the belt operate for approximately 15 seconds. Notice if the Walking Belt needs to be adjusted so it runs centered on the machine.

**⚠ Be sure not to touch the walking belt or step on the power cord. Keep bystanders, children and pets away from the machine you are servicing at all times.**

39. If the Walking Belt needs to be adjusted, use a 6mm hex wrench on the side the belt should move away from and rotate the Adjustment Bolt a 1/4 turn clock-wise.

40. Allow the Walking Belt to adjust to the new tension by allowing it to run a couple seconds.

41. Repeat steps 39 and 40 until the Walking Belt is centered.

42. Switch off your machine.

43. Take care to clean up any excess lubricant from the deck.

**⚠ To decrease the possibility of slipping, be sure the deck area is free from grease or oil. Clean off any excess oil from the machine surfaces.**

44. Final Inspection

Inspect your machine to ensure that all hardware is tight and components are properly assembled.

**⚠ Do not use until the machine has been fully assembled and inspected for correct performance in accordance with the Owner's Manual.**



**NOTICE:** This document provides instructions for the replacement of the Motor Control Board (MCB) on the Schwinn™ 810 / 510T machine.

If you need assistance, please contact Customer Service (if purchased in US/Canada) or your local distributor (if purchased outside US/Canada). To find your local distributor, go to: [www.nautilusinternational.com](http://www.nautilusinternational.com)

 This icon means a potentially hazardous situation which, if not avoided, could result in death or serious injury. Read and understand all Warnings on this machine.

Nautilus, Inc., [www.NautilusInc.com](http://www.NautilusInc.com), 5415 Centerpoint Parkway, Groveport, OH 43125 U.S.A. - Customer Service: North America (800) 605-3369, [csnls@nautilus.com](mailto:csnls@nautilus.com) | outside U.S. [www.nautilusinternational.com](http://www.nautilusinternational.com) | Printed in China | © 2019 Nautilus, Inc. | Schwinn and the Schwinn logo are trademarks owned or licensed by Nautilus, Inc., registered or otherwise protected by common law in the United States and other nations. | **ORIGINAL DOCUMENT - ENGLISH VERSION ONLY**

### Important Safety Instructions - Before servicing or using this equipment, obey the following warnings:

 This icon means a potentially hazardous situation which, if not avoided, could result in death or serious injury. Read and understand all Warnings on this machine.

 **DANGER** To reduce the risk of electrical shock or unsupervised usage of the equipment, always unplug the power cord from the wall outlet and wait 5 minutes before cleaning, maintaining or repairing this machine. Place the power cord in a secure location.

- Read and understand the Part Replacement Procedure before working on the machine. Failure to obey the instructions and safety warnings could cause injury to the service technician or bystanders.
- Keep bystanders, children and pets away from the product being serviced at all times.
- Make sure that the repair is done in an appropriate work space away from foot traffic and exposure to bystanders.
- Disconnect all power and allow to sit for 5 minutes before you service this machine.
- Some components of the equipment can be heavy or awkward. Enlist the service of a second person when you do maintenance steps involving these components. Do not try to do heavy or awkward steps on your own.
- If replacement parts are necessary, use only genuine Nautilus replacement parts and hardware. Failure to use genuine replacement parts can cause a risk to users, keep the machine from operating correctly and will void the warranty.
- Be sure that all warning stickers and instructional placards applied to the product stay present and in good condition when doing maintenance or replacing components. If at any time the Warning labels become loose, unreadable or dislodged, replace the labels. If purchased in US/Canada, contact Customer Service for replacement labels. If purchased outside US/Canada, contact your local distributor for them.
- Do not try to change the design or functionality of the machine being serviced as this can adversely effect user safety and will void the warranty.
- Do not use the machine until all shrouds, instructions, warning labels and correct functionality have been verified and tested for correct performance.

• **SAVE THESE INSTRUCTIONS.**

#### Tools Required (not included)

#2 Phillips screwdriver

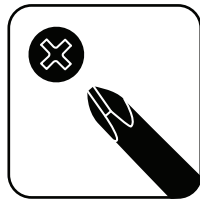



# ⚠ DANGER

To reduce the risk of electrical shock or unsupervised usage of the equipment, always unplug the power cord from the wall outlet and wait 5 minutes before cleaning, maintaining or repairing this machine. Place the power cord in a secure location.

1. Unplug the power cord from the machine and wait 5 minutes. Place the power cord in a secure location.

2. Using a #2 Phillips screwdriver remove the 4 indicated screws from the Motor Cover.



3. Using the support bar found below the rear of the walking belt, lift the walking deck fully upward and engage the hydraulic lift. Be sure that the hydraulic lift is correctly locked in place. You will hear an audible click when the hydraulic lift shifts into the locked position.

**⚠ Use proper safety precautions and lifting techniques. Bend your knees and elbows, keep your back straight and pull up equally with both arms. Straighten your legs to lift. Make sure that your own physical strength is capable of lifting the walking deck until it engages the locking mechanism. Use a second person if necessary.**

**Do not use the walking belt or rear roller to lift the treadmill. These parts do not lock in place and can abruptly move. Injury to you or damage to the machine can occur.**

4. Make sure that the locking mechanism is engaged. Carefully pull back on the walking deck and make sure that it does not move. When you do this, keep clear of movement path in case the treadmill lock is not properly engaged.

**⚠ Do not lean against the treadmill when it is folded. Do not put items on it that could cause it to become unstable or fall.**





5. Using a #2 Phillips screwdriver remove the 2 indicated screws from the Motor Cover and remove it.



6. Make sure there is sufficient space to lower the walking deck.

**!** Keep a minimum clearance behind the machine of 79" (2 m) and 19.7" (0.5 m) on each side. This is the recommended safe distance for access, movement and emergency dismounts from the machine.

7. Make sure there is no object on or around the treadmill to spill or cause blockage from the fully unfolded position.

8. Slightly push the walking deck forward toward the console. With your foot lightly push the top part of the hydraulic lift forward until the locking tube releases and you can pull the walking deck away from the console. Hold up the rear of the walking deck, and move to the side of the machine.



**!** Keep clear of the movement path of the walking deck.

9. The hydraulic lift is set up to drop gradually. Hold onto the walking deck until approximately 2/3 of the movement down. Lower the weight with your legs. Be aware that the walking deck can possibly drop quickly in the last part of the movement.

**!** If you used spray lubricant, wait 5 minutes before turning on power to the machine to allow the aerosol to dissipate.

10. Remove the connectors from the Motor Control Board after noting their locations.

**Note:** Be sure to note where all cables attach for re-assembly.

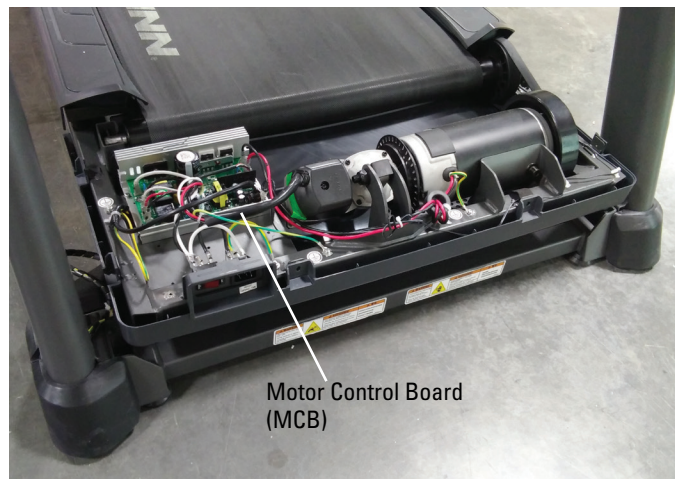

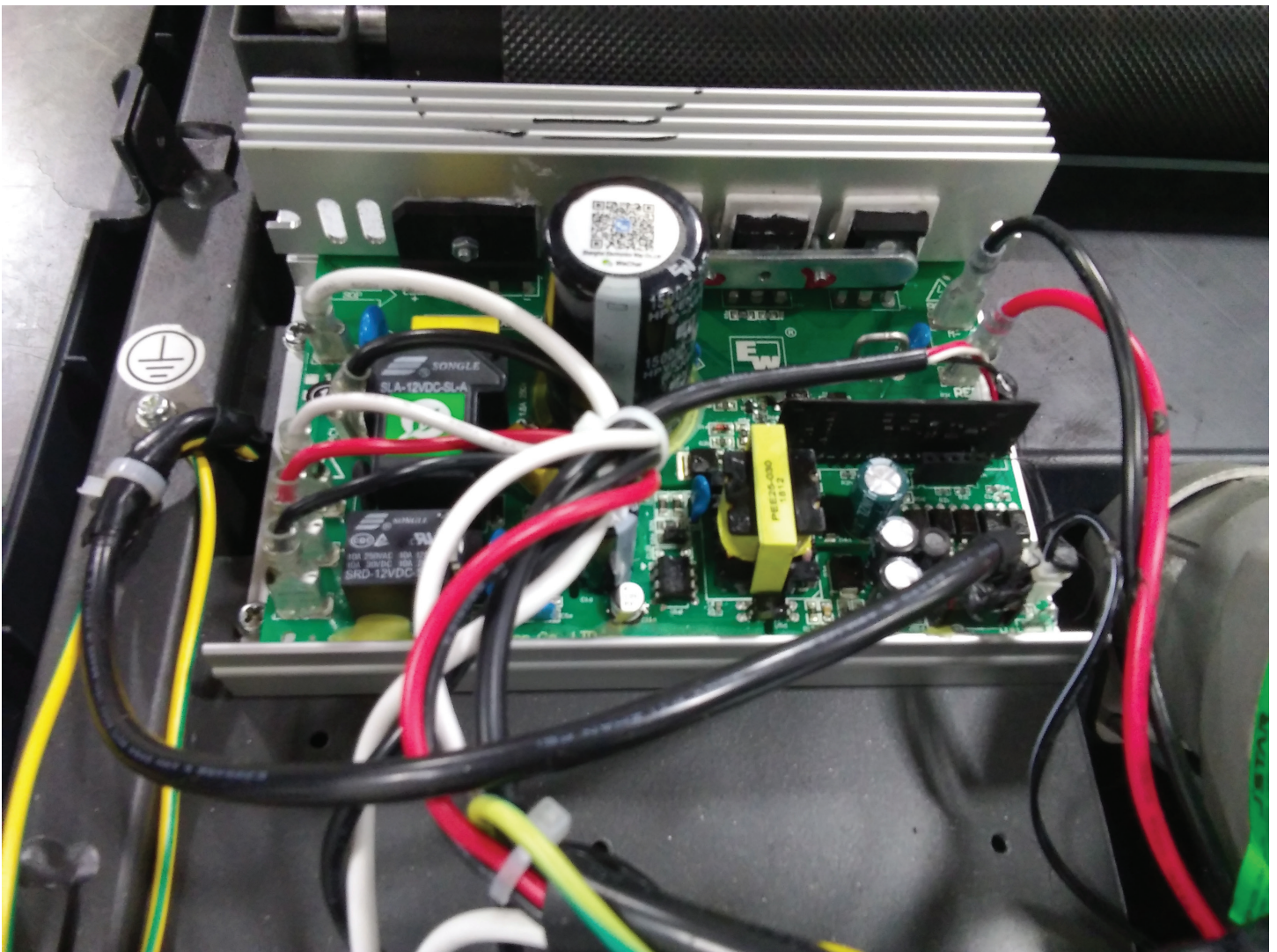
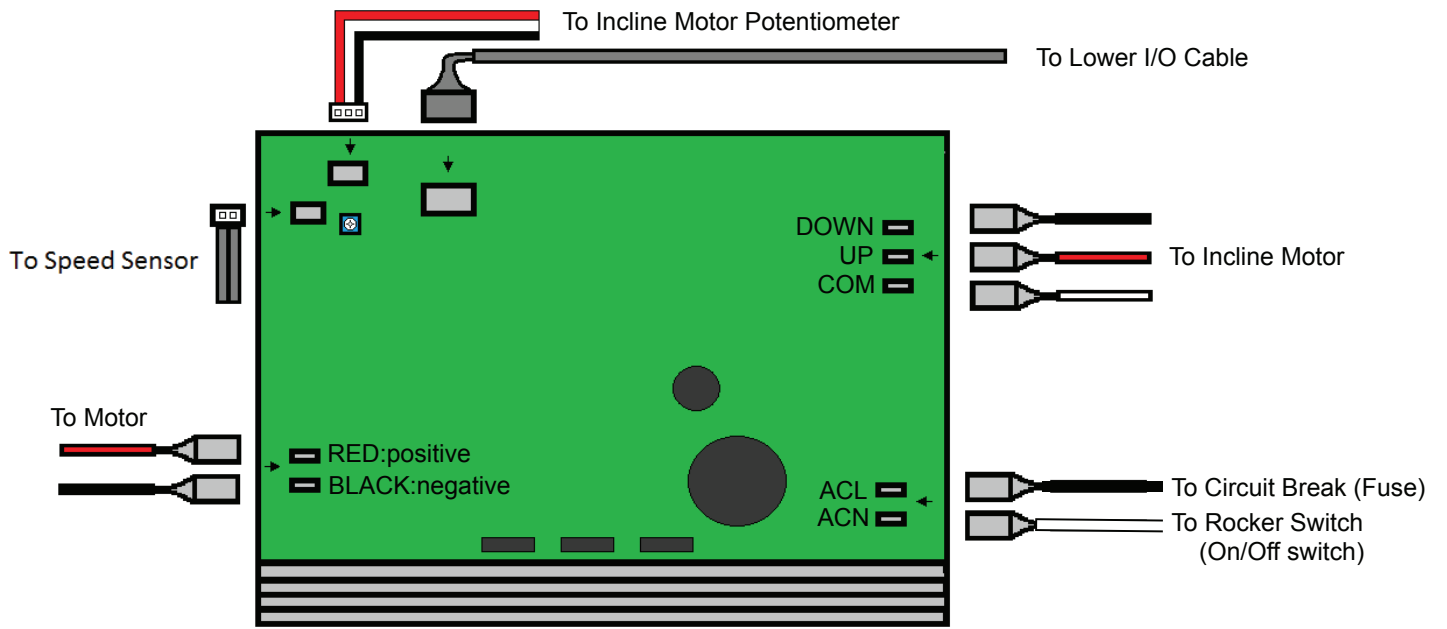



11. Using a #2 Phillips screwdriver, remove the 4 indicated screws that attach the Motor Control Board (MCB) to the Frame.

12. Remove old Motor Control Board, and install the new Motor Control Board. Connect all the cables to the MCB in their proper locations. Be sure not to pinch or cut the cables.

13. Re-install all remaining parts that were removed in reverse order.

14. Attach the power cord and turn on the Treadmill by flipping the power switch to ON.

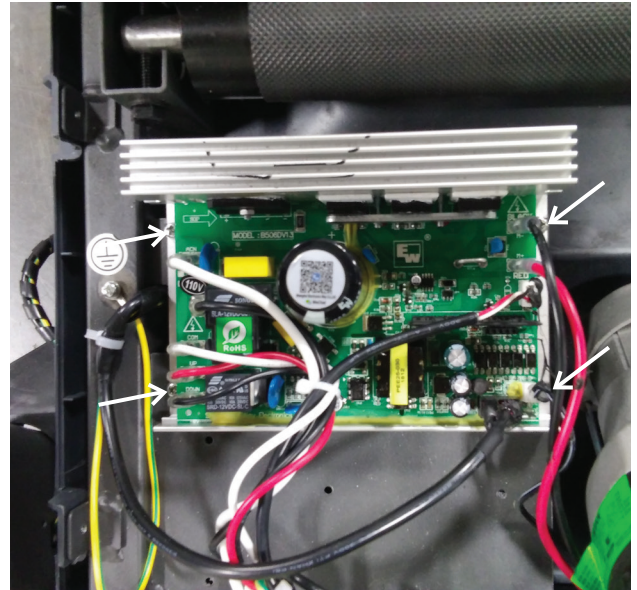

15. Stand next to the machine where the Console can easily be reached.

**⚠ Be sure the area around the Treadmill is clear of all bystanders, children and pets. Be sure there is nothing on or under the Walking Belt, or near the Treadmill.**

16. Push and hold down the Pause/Stop and Enter buttons until machine enters engineering mode.

17. Push the Start button 8 times.

18. The calibration procedure will begin by automatically moving the Walking Belt and adjusting the incline of the Walking Deck for about a minute. Then the console will flash and beep.

**⚠ Be sure not to touch or allow anyone else to touch the machine while calibration is occurring.**



19. The calibration procedure is now complete.

20. Final Inspection  
Inspect your machine to ensure that all hardware is tight and components are properly assembled.

**⚠ Do not use until the machine has been fully assembled and inspected for correct performance in accordance with the Owner's Manual.**

**NOTICE:** This document provides instructions for the replacement of the Motor Cover on the Schwinn™ 810 / 510T machine.

If you need assistance, please contact Customer Service (if purchased in US/Canada) or your local distributor (if purchased outside US/Canada). To find your local distributor, go to: [www.nautilusinternational.com](http://www.nautilusinternational.com)

 This icon means a potentially hazardous situation which, if not avoided, could result in death or serious injury. Read and understand all Warnings on this machine.

Nautilus, Inc., [www.NautilusInc.com](http://www.NautilusInc.com), 5415 Centerpoint Parkway, Groveport, OH 43125 U.S.A. - Customer Service: North America (800) 605-3369, [csnls@nautilus.com](mailto:csnls@nautilus.com) | outside U.S. [www.nautilusinternational.com](http://www.nautilusinternational.com) | Printed in China | © 2019 Nautilus, Inc. | Schwinn and the Schwinn logo are trademarks owned or licensed by Nautilus, Inc., registered or otherwise protected by common law in the United States and other nations. | **ORIGINAL DOCUMENT - ENGLISH VERSION ONLY**

**Important Safety Instructions - Before servicing or using this equipment, obey the following warnings:**

 This icon means a potentially hazardous situation which, if not avoided, could result in death or serious injury. Read and understand all Warnings on this machine.

 **DANGER** To reduce the risk of electrical shock or unsupervised usage of the equipment, always unplug the power cord from the wall outlet and wait 5 minutes before cleaning, maintaining or repairing this machine. Place the power cord in a secure location.

- Read and understand the Part Replacement Procedure before working on the machine. Failure to obey the instructions and safety warnings could cause injury to the service technician or bystanders.
- Keep bystanders, children and pets away from the product being serviced at all times.
- Make sure that the repair is done in an appropriate work space away from foot traffic and exposure to bystanders.
- Disconnect all power and allow to sit for 5 minutes before you service this machine.
- Some components of the equipment can be heavy or awkward. Enlist the service of a second person when you do maintenance steps involving these components. Do not try to do heavy or awkward steps on your own.
- If replacement parts are necessary, use only genuine Nautilus replacement parts and hardware. Failure to use genuine replacement parts can cause a risk to users, keep the machine from operating correctly and will void the warranty.
- Be sure that all warning stickers and instructional placards applied to the product stay present and in good condition when doing maintenance or replacing components. If at any time the Warning labels become loose, unreadable or dislodged, replace the labels. If purchased in US/Canada, contact Customer Service for replacement labels. If purchased outside US/Canada, contact your local distributor for them.
- Do not try to change the design or functionality of the machine being serviced as this can adversely effect user safety and will void the warranty.
- Do not use the machine until all shrouds, instructions, warning labels and correct functionality have been verified and tested for correct performance.

**• SAVE THESE INSTRUCTIONS.**

**Tools Required (not included)**

#2 Phillips screwdriver

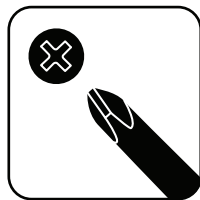



# **⚠ DANGER**

To reduce the risk of electrical shock or unsupervised usage of the equipment, always unplug the power cord from the wall outlet and wait 5 minutes before cleaning, maintaining or repairing this machine. Place the power cord in a secure location.

1. Unplug the power cord from the machine and wait 5 minutes. Place the power cord in a secure location.

2. Using a #2 Phillips screwdriver remove the 4 indicated screws from the Motor Cover.



3. Make sure that there is safe clearance around, on and above the treadmill. Make sure there is no object to spill or cause blockage from the fully folded position.

**⚠ Be sure there is adequate height clearance for the raised deck.**

4. Using the support bar found below the rear of the walking belt, lift the walking deck fully upward and engage the hydraulic lift. Be sure that the hydraulic lift is correctly locked in place. You will hear an audible click when the hydraulic lift shifts into the locked position.

**⚠ Use proper safety precautions and lifting techniques. Bend your knees and elbows, keep your back straight and pull up equally with both arms. Straighten your legs to lift. Make sure that your own physical strength is capable of lifting the walking deck until it engages the locking mechanism. Use a second person if necessary.**

**Do not use the walking belt or rear roller to lift the treadmill. These parts do not lock in place and can abruptly move. Injury to you or damage to the machine can occur.**

5. Make sure that the locking mechanism is engaged. Carefully pull back on the walking deck and make sure that it does not move. When you do this, keep clear of movement path in case the treadmill lock is not properly engaged.

**⚠ Do not lean against the treadmill when it is folded. Do not put items on it that could cause it to become unstable or fall.**



6. Using a #2 Phillips screwdriver remove the 2 indicated screws from the Motor Cover and remove it.



7. Installation of the new Motor Cover is the reverse procedure.

8. Make sure there is sufficient space to lower the walking deck.

**⚠ Keep a minimum clearance behind the machine of 79" (2 m) and 19.7" (0.5 m) on each side. This is the recommended safe distance for access, movement and emergency dismounts from the machine.**

9. Make sure there is no object on or around the treadmill to spill or cause blockage from the fully unfolded position.



10. Slightly push the walking deck forward toward the console. With your foot lightly push the top part of the hydraulic lift forward until the locking tube releases and you can pull the walking deck away from the console. Hold up the rear of the walking deck, and move to the side of the machine.

**⚠ Keep clear of the movement path of the walking deck.**

11. The hydraulic lift is set up to drop gradually. Hold onto the walking deck until approximately 2/3 of the movement down. Lower the weight with your legs. Be aware that the walking deck can possibly drop quickly in the last part of the movement.

12. Final Inspection

Inspect your machine to ensure that all hardware is tight and components are properly assembled.

**⚠ Do not use until the machine has been fully assembled and inspected for correct performance in accordance with the Owner's Manual.**

**NOTICE:** This document provides instructions for the replacement of the Power Inlet on the Schwinn™ 810 / 510T machine.

If you need assistance, please contact Customer Service (if purchased in US/Canada) or your local distributor (if purchased outside US/Canada). To find your local distributor, go to: [www.nautilusinternational.com](http://www.nautilusinternational.com)

**!** This icon means a potentially hazardous situation which, if not avoided, could result in death or serious injury. Read and understand all Warnings on this machine.

Nautilus, Inc., [www.NautilusInc.com](http://www.NautilusInc.com), 5415 Centerpoint Parkway, Groveport, OH 43125 U.S.A. - Customer Service: North America (800) 605-3369, [csnls@nautilus.com](mailto:csnls@nautilus.com) | outside U.S. [www.nautilusinternational.com](http://www.nautilusinternational.com) | Printed in China | © 2019 Nautilus, Inc. | Schwinn and the Schwinn logo are trademarks owned or licensed by Nautilus, Inc., registered or otherwise protected by common law in the United States and other nations. | **ORIGINAL DOCUMENT - ENGLISH VERSION ONLY**

### Important Safety Instructions - Before servicing or using this equipment, obey the following warnings:

**!** This icon means a potentially hazardous situation which, if not avoided, could result in death or serious injury. Read and understand all Warnings on this machine.

**! DANGER** To reduce the risk of electrical shock or unsupervised usage of the equipment, always unplug the power cord from the wall outlet and wait 5 minutes before cleaning, maintaining or repairing this machine. Place the power cord in a secure location.

- Read and understand the Part Replacement Procedure before working on the machine. Failure to obey the instructions and safety warnings could cause injury to the service technician or bystanders.
- Keep bystanders, children and pets away from the product being serviced at all times.
- Make sure that the repair is done in an appropriate work space away from foot traffic and exposure to bystanders.
- Disconnect all power and allow to sit for 5 minutes before you service this machine.
- Some components of the equipment can be heavy or awkward. Enlist the service of a second person when you do maintenance steps involving these components. Do not try to do heavy or awkward steps on your own.
- If replacement parts are necessary, use only genuine Nautilus replacement parts and hardware. Failure to use genuine replacement parts can cause a risk to users, keep the machine from operating correctly and will void the warranty.
- Be sure that all warning stickers and instructional placards applied to the product stay present and in good condition when doing maintenance or replacing components. If at any time the Warning labels become loose, unreadable or dislodged, replace the labels. If purchased in US/Canada, contact Customer Service for replacement labels. If purchased outside US/Canada, contact your local distributor for them.
- Do not try to change the design or functionality of the machine being serviced as this can adversely effect user safety and will void the warranty.
- Do not use the machine until all shrouds, instructions, warning labels and correct functionality have been verified and tested for correct performance.

### • SAVE THESE INSTRUCTIONS.

#### Tools Required (not included)

#2 Phillips screwdriver





# **⚠ DANGER**

To reduce the risk of electrical shock or unsupervised usage of the equipment, always unplug the power cord from the wall outlet and wait 5 minutes before cleaning, maintaining or repairing this machine. Place the power cord in a secure location.

1. Unplug the power cord from the machine and wait 5 minutes. Place the power cord in a secure location.

2. Using a #2 Phillips screwdriver remove the 4 indicated screws from the Motor Cover.



3. Using the support bar found below the rear of the walking belt, lift the walking deck fully upward and engage the hydraulic lift. Be sure that the hydraulic lift is correctly locked in place. You will hear an audible click when the hydraulic lift shifts into the locked position.

**⚠ Use proper safety precautions and lifting techniques. Bend your knees and elbows, keep your back straight and pull up equally with both arms. Straighten your legs to lift. Make sure that your own physical strength is capable of lifting the walking deck until it engages the locking mechanism. Use a second person if necessary.**

**Do not use the walking belt or rear roller to lift the treadmill. These parts do not lock in place and can abruptly move. Injury to you or damage to the machine can occur.**



4. Make sure that the locking mechanism is engaged. Carefully pull back on the walking deck and make sure that it does not move. When you do this, keep clear of movement path in case the treadmill lock is not properly engaged.

**⚠ Do not lean against the treadmill when it is folded. Do not put items on it that could cause it to become unstable or fall.**





5. Using a #2 Phillips screwdriver remove the 2 indicated screws from the Motor Cover and remove it.



6. Make sure there is sufficient space to lower the walking deck.

**!** Keep a minimum clearance behind the machine of 79" (2 m) and 19.7" (0.5 m) on each side. This is the recommended safe distance for access, movement and emergency dismounts from the machine.

7. Make sure there is no object on or around the treadmill to spill or cause blockage from the fully unfolded position.

8. Slightly push the walking deck forward toward the console. With your foot lightly push the top part of the hydraulic lift forward until the locking tube releases and you can pull the walking deck away from the console. Hold up the rear of the walking deck, and move to the side of the machine.

**!** Keep clear of the movement path of the walking deck.

9. The hydraulic lift is set up to drop gradually. Hold onto the walking deck until approximately 2/3 of the movement down. Lower the weight with your legs. Be aware that the walking deck can possibly drop quickly in the last part of the movement.



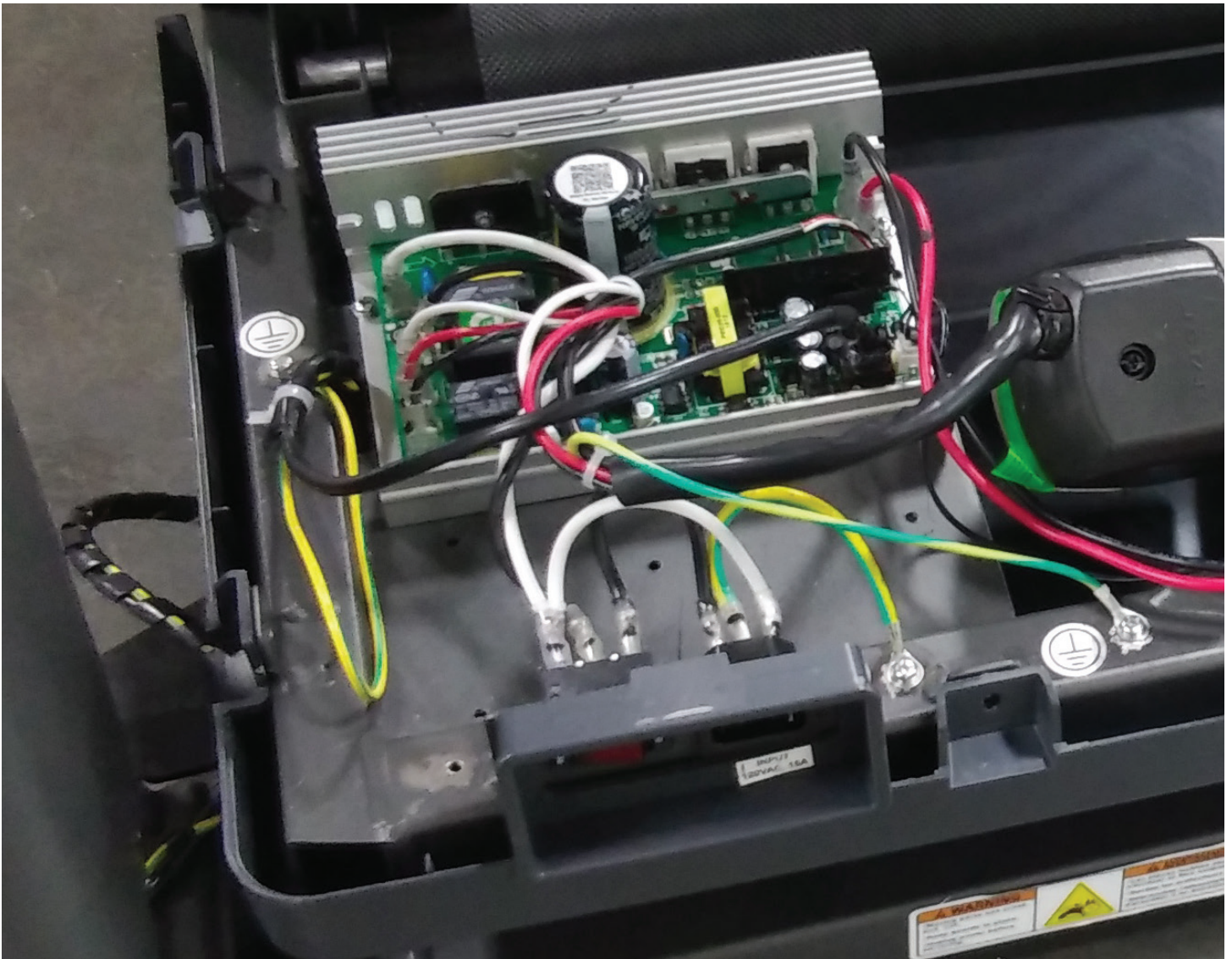
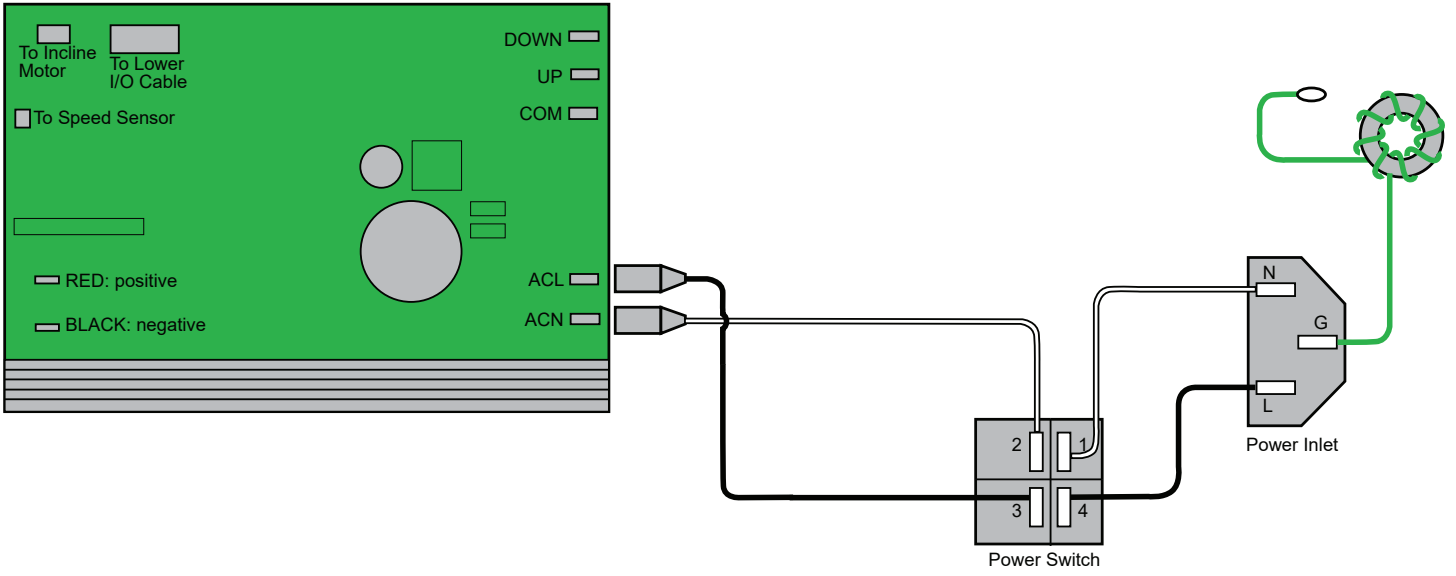

10. Release the Securing Clips from the Power Inlet and remove it from the Frame.

11. Remove the connectors and attach them to the new Power Inlet. Be sure to attach them in the same locations on the new Power Inlet.

12. Insert the new Power Inlet into the Frame being sure the Securing Clips engage.

**Note:** Do not pinch or cut the cables.

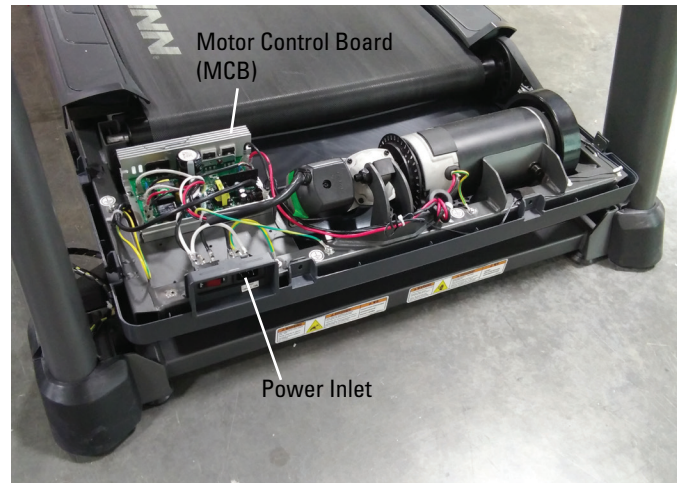

13. Re-install all remaining parts that were removed in reverse order.

#### 14. Final Inspection

Inspect your machine to ensure that all hardware is tight and components are properly assembled.



**Do not use until the machine has been fully assembled and inspected for correct performance in accordance with the Owner's Manual.**

**NOTICE:** This document provides instructions for the replacement of the Rear Roller on the Schwinn™ 810 / 510T machine.

If you need assistance, please contact Customer Service (if purchased in US/Canada) or your local distributor (if purchased outside US/Canada). To find your local distributor, go to: [www.nautilusinternational.com](http://www.nautilusinternational.com)

**!** This icon means a potentially hazardous situation which, if not avoided, could result in death or serious injury. Read and understand all Warnings on this machine.

Nautilus, Inc., [www.NautilusInc.com](http://www.NautilusInc.com), 5415 Centerpoint Parkway, Groveport, OH 43125 U.S.A. - Customer Service: North America (800) 605-3369, [csnls@nautilus.com](mailto:csnls@nautilus.com) | outside U.S. [www.nautilusinternational.com](http://www.nautilusinternational.com) | Printed in China | © 2019 Nautilus, Inc. | Schwinn and the Schwinn logo are trademarks owned or licensed by Nautilus, Inc., registered or otherwise protected by common law in the United States and other nations. | **ORIGINAL DOCUMENT - ENGLISH VERSION ONLY**

**Important Safety Instructions - Before servicing or using this equipment, obey the following warnings:**

**!** This icon means a potentially hazardous situation which, if not avoided, could result in death or serious injury. Read and understand all Warnings on this machine.

**DANGER** To reduce the risk of electrical shock or unsupervised usage of the equipment, always unplug the power cord from the wall outlet and wait 5 minutes before cleaning, maintaining or repairing this machine. Place the power cord in a secure location.

- Read and understand the Part Replacement Procedure before working on the machine. Failure to obey the instructions and safety warnings could cause injury to the service technician or bystanders.
- Keep bystanders, children and pets away from the product being serviced at all times.
- Make sure that the repair is done in an appropriate work space away from foot traffic and exposure to bystanders.
- Disconnect all power and allow to sit for 5 minutes before you service this machine.
- Some components of the equipment can be heavy or awkward. Enlist the service of a second person when you do maintenance steps involving these components. Do not try to do heavy or awkward steps on your own.
- If replacement parts are necessary, use only genuine Nautilus replacement parts and hardware. Failure to use genuine replacement parts can cause a risk to users, keep the machine from operating correctly and will void the warranty.
- Be sure that all warning stickers and instructional placards applied to the product stay present and in good condition when doing maintenance or replacing components. If at any time the Warning labels become loose, unreadable or dislodged, replace the labels. If purchased in US/Canada, contact Customer Service for replacement labels. If purchased outside US/Canada, contact your local distributor for them.
- Do not try to change the design or functionality of the machine being serviced as this can adversely effect user safety and will void the warranty.
- Do not use the machine until all shrouds, instructions, warning labels and correct functionality have been verified and tested for correct performance.

**• SAVE THESE INSTRUCTIONS.**

**Tools Required (not included)**

#2 Phillips screwdriver

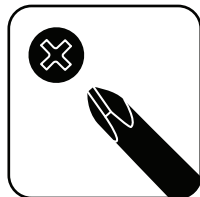



# **! DANGER**

To reduce the risk of electrical shock or unsupervised usage of the equipment, always unplug the power cord from the wall outlet and wait 5 minutes before cleaning, maintaining or repairing this machine. Place the power cord in a secure location.

1. Unplug the power cord from the machine and wait 5 minutes. Place the power cord in a secure location.

2. Make sure that there is safe clearance around, on and above the treadmill. Make sure there is no object to spill or cause blockage from the fully folded position.

**! Be sure there is adequate height clearance for the raised deck.**

3. Using the support bar found below the rear of the walking belt, lift the walking deck fully upward and engage the hydraulic lift. Be sure that the hydraulic lift is correctly locked in place. You will hear an audible click when the hydraulic lift shifts into the locked position.

**! Use proper safety precautions and lifting techniques. Bend your knees and elbows, keep your back straight and pull up equally with both arms. Straighten your legs to lift. Make sure that your own physical strength is capable of lifting the walking deck until it engages the locking mechanism. Use a second person if necessary.**

**Do not use the walking belt or rear roller to lift the treadmill. These parts do not lock in place and can abruptly move. Injury to you or damage to the machine can occur.**

4. Make sure that the locking mechanism is engaged. Carefully pull back on the walking deck and make sure that it does not move. When you do this, keep clear of movement path in case the treadmill lock is not properly engaged.

**! Do not lean against the treadmill when it is folded. Do not put items on it that could cause it to become unstable or fall.**



5. Using a #2 Phillips screwdriver, remove the indicated screw (with arrows) from the Rear Roller Cover.

6. Replace the old Rear Roller Cover with the new Rear Roller Cover.

7. Using a #2 Phillips screwdriver, secure the new Rear Roller Cover to the machine.

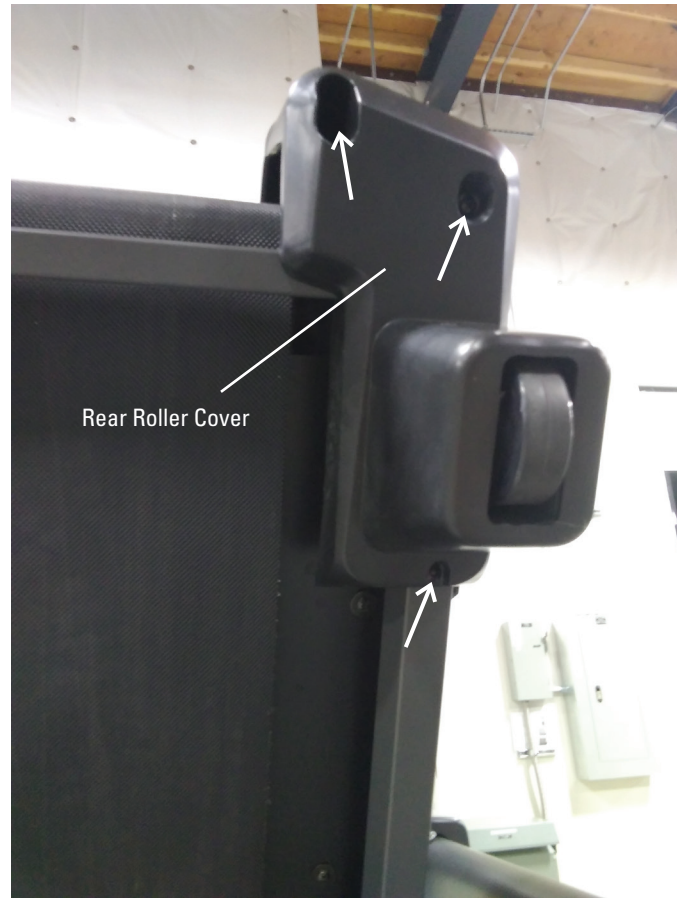

8. Make sure there is sufficient space to lower the walking deck.

**⚠ Keep a minimum clearance behind the machine of 79" (2 m) and 19.7" (0.5 m) on each side. This is the recommended safe distance for access, movement and emergency dismounts from the machine.**

9. Make sure there is no object on or around the treadmill to spill or cause blockage from the fully unfolded position.

10. Slightly push the walking deck forward toward the console. With your foot lightly push the top part of the hydraulic lift forward until the locking tube releases and you can pull the walking deck away from the console. Hold up the rear of the walking deck, and move to the side of the machine.

**⚠ Keep clear of the movement path of the walking deck.**

11. The hydraulic lift is set up to drop gradually. Hold onto the walking deck until approximately 2/3 of the movement down. Lower the weight with your legs. Be aware that the walking deck can possibly drop quickly in the last part of the movement.



12. Using a 6mm hex wrench, remove both of the Adjustment Bolts from the Rear Roller.

**Note:** Be sure to record the number of turns of the Adjustment Bolt it takes to remove it. This will assist with reassembly.

13. Slide the Rear Roller out of the Walking Belt.

14. Slide the new Rear Roller into the new Walking Belt in the same orientation.

15. Using a 6mm hex wrench, re-attach the Adjustment Bolt to the Rear Roller.

**Note:** Be sure to tighten the Adjustment Bolt the same number of turns it took to loosen the Walking Belt.

16. Re-install all remaining parts that were removed in reverse order.

17. Final Inspection

Inspect your machine to ensure that all hardware is tight and components are properly assembled.



**Do not use until the machine has been fully assembled and inspected for correct performance in accordance with the Owner's Manual.**

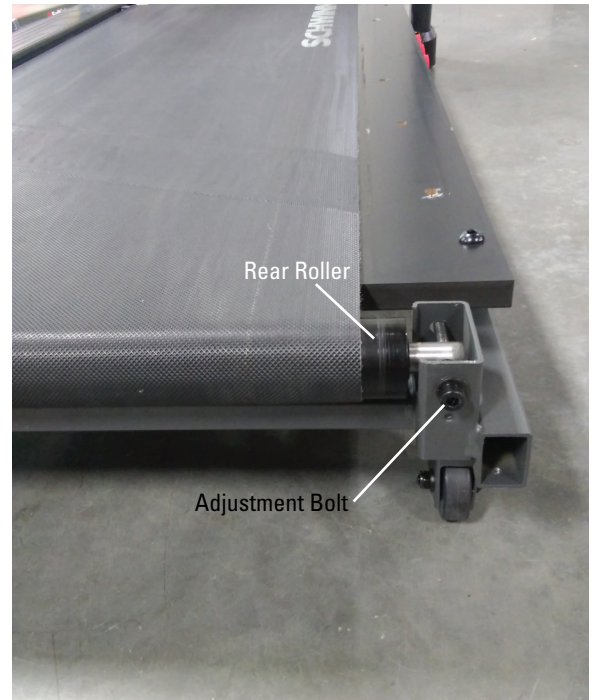

**NOTICE:** This document provides instructions for the replacement of the Rear Roller Cover on the Schwinn™ 810 / 510T machine.

If you need assistance, please contact Customer Service (if purchased in US/Canada) or your local distributor (if purchased outside US/Canada). To find your local distributor, go to: [www.nautilusinternational.com](http://www.nautilusinternational.com)

**!** This icon means a potentially hazardous situation which, if not avoided, could result in death or serious injury. Read and understand all Warnings on this machine.

Nautilus, Inc., [www.NautilusInc.com](http://www.NautilusInc.com), 5415 Centerpoint Parkway, Groveport, OH 43125 U.S.A. - Customer Service: North America (800) 605-3369, [csnls@nautilus.com](mailto:csnls@nautilus.com) | outside U.S. [www.nautilusinternational.com](http://www.nautilusinternational.com) | Printed in China | © 2019 Nautilus, Inc. | Schwinn and the Schwinn logo are trademarks owned or licensed by Nautilus, Inc., registered or otherwise protected by common law in the United States and other nations. | **ORIGINAL DOCUMENT - ENGLISH VERSION ONLY**

### Important Safety Instructions - Before servicing or using this equipment, obey the following warnings:

**!** This icon means a potentially hazardous situation which, if not avoided, could result in death or serious injury. Read and understand all Warnings on this machine.

**! DANGER** To reduce the risk of electrical shock or unsupervised usage of the equipment, always unplug the power cord from the wall outlet and wait 5 minutes before cleaning, maintaining or repairing this machine. Place the power cord in a secure location.

- Read and understand the Part Replacement Procedure before working on the machine. Failure to obey the instructions and safety warnings could cause injury to the service technician or bystanders.
- Keep bystanders, children and pets away from the product being serviced at all times.
- Make sure that the repair is done in an appropriate work space away from foot traffic and exposure to bystanders.
- Disconnect all power and allow to sit for 5 minutes before you service this machine.
- Some components of the equipment can be heavy or awkward. Enlist the service of a second person when you do maintenance steps involving these components. Do not try to do heavy or awkward steps on your own.
- If replacement parts are necessary, use only genuine Nautilus replacement parts and hardware. Failure to use genuine replacement parts can cause a risk to users, keep the machine from operating correctly and will void the warranty.
- Be sure that all warning stickers and instructional placards applied to the product stay present and in good condition when doing maintenance or replacing components. If at any time the Warning labels become loose, unreadable or dislodged, replace the labels. If purchased in US/Canada, contact Customer Service for replacement labels. If purchased outside US/Canada, contact your local distributor for them.
- Do not try to change the design or functionality of the machine being serviced as this can adversely effect user safety and will void the warranty.
- Do not use the machine until all shrouds, instructions, warning labels and correct functionality have been verified and tested for correct performance.

### • SAVE THESE INSTRUCTIONS.

#### Tools Required (not included)

#2 Phillips screwdriver

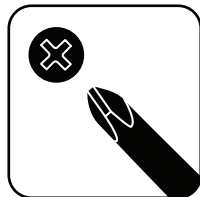



# **! DANGER**

To reduce the risk of electrical shock or unsupervised usage of the equipment, always unplug the power cord from the wall outlet and wait 5 minutes before cleaning, maintaining or repairing this machine. Place the power cord in a secure location.

1. Unplug the power cord from the machine and wait 5 minutes. Place the power cord in a secure location.

2. Make sure that there is safe clearance around, on and above the treadmill. Make sure there is no object to spill or cause blockage from the fully folded position.

**! Be sure there is adequate height clearance for the raised deck.**

3. Using the support bar found below the rear of the walking belt, lift the walking deck fully upward and engage the hydraulic lift. Be sure that the hydraulic lift is correctly locked in place. You will hear an audible click when the hydraulic lift shifts into the locked position.

**! Use proper safety precautions and lifting techniques. Bend your knees and elbows, keep your back straight and pull up equally with both arms. Straighten your legs to lift. Make sure that your own physical strength is capable of lifting the walking deck until it engages the locking mechanism. Use a second person if necessary.**

**Do not use the walking belt or rear roller to lift the treadmill. These parts do not lock in place and can abruptly move. Injury to you or damage to the machine can occur.**

4. Make sure that the locking mechanism is engaged. Carefully pull back on the walking deck and make sure that it does not move. When you do this, keep clear of movement path in case the treadmill lock is not properly engaged.

**! Do not lean against the treadmill when it is folded. Do not put items on it that could cause it to become unstable or fall.**



5. Using a #2 Phillips screwdriver, remove the indicated screw (with arrows) from the Rear Roller Cover.

6. Replace the old Rear Roller Cover with the new Rear Roller Cover.

7. Using a #2 Phillips screwdriver, secure the new Rear Roller Cover to the machine.

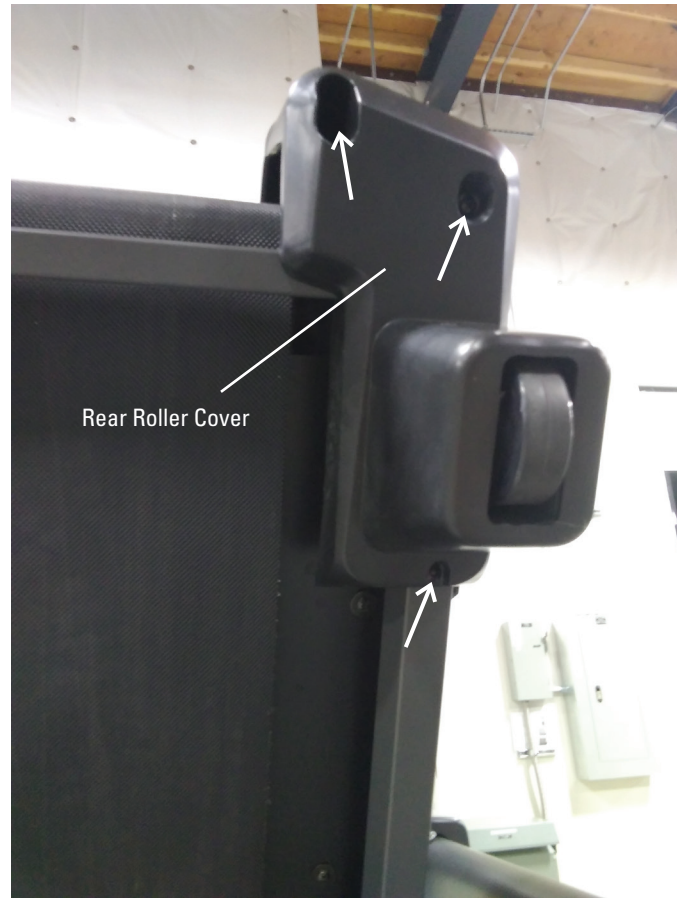

8. Make sure there is sufficient space to lower the walking deck.

**!** Keep a minimum clearance behind the machine of 79" (2 m) and 19.7" (0.5 m) on each side. This is the recommended safe distance for access, movement and emergency dismounts from the machine.

9. Make sure there is no object on or around the treadmill to spill or cause blockage from the fully unfolded position.

10. Slightly push the walking deck forward toward the console. With your foot lightly push the top part of the hydraulic lift forward until the locking tube releases and you can pull the walking deck away from the console. Hold up the rear of the walking deck, and move to the side of the machine.

**!** Keep clear of the movement path of the walking deck.

11. The hydraulic lift is set up to drop gradually. Hold onto the walking deck until approximately 2/3 of the movement down. Lower the weight with your legs. Be aware that the walking deck can possibly drop quickly in the last part of the movement.



12. Final Inspection

Inspect your machine to ensure that all hardware is tight and components are properly assembled.

**!** Do not use until the machine has been fully assembled and inspected for correct performance in accordance with the Owner's Manual.

**NOTICE:** This document provides instructions for the replacement of the Right Upright on the Schwinn™ 810 / 510T machine.

If you need assistance, please contact Customer Service (if purchased in US/Canada) or your local distributor (if purchased outside US/Canada). To find your local distributor, go to: [www.nautilusinternational.com](http://www.nautilusinternational.com)

**!** This icon means a potentially hazardous situation which, if not avoided, could result in death or serious injury. Read and understand all Warnings on this machine.

Nautilus, Inc., [www.NautilusInc.com](http://www.NautilusInc.com), 5415 Centerpoint Parkway, Groveport, OH 43125 U.S.A. - Customer Service: North America (800) 605-3369, [csnls@nautilus.com](mailto:csnls@nautilus.com) | outside U.S. [www.nautilusinternational.com](http://www.nautilusinternational.com) | Printed in China | © 2019 Nautilus, Inc. | Schwinn and the Schwinn logo are trademarks owned or licensed by Nautilus, Inc., registered or otherwise protected by common law in the United States and other nations. | **ORIGINAL DOCUMENT - ENGLISH VERSION ONLY**

**Important Safety Instructions - Before servicing or using this equipment, obey the following warnings:**

**!** This icon means a potentially hazardous situation which, if not avoided, could result in death or serious injury. Read and understand all Warnings on this machine.

**DANGER** To reduce the risk of electrical shock or unsupervised usage of the equipment, always unplug the power cord from the wall outlet and wait 5 minutes before cleaning, maintaining or repairing this machine. Place the power cord in a secure location.

- Read and understand the Part Replacement Procedure before working on the machine. Failure to obey the instructions and safety warnings could cause injury to the service technician or bystanders.
- Keep bystanders, children and pets away from the product being serviced at all times.
- Make sure that the repair is done in an appropriate work space away from foot traffic and exposure to bystanders.
- Disconnect all power and allow to sit for 5 minutes before you service this machine.
- Some components of the equipment can be heavy or awkward. Enlist the service of a second person when you do maintenance steps involving these components. Do not try to do heavy or awkward steps on your own.
- If replacement parts are necessary, use only genuine Nautilus replacement parts and hardware. Failure to use genuine replacement parts can cause a risk to users, keep the machine from operating correctly and will void the warranty.
- Be sure that all warning stickers and instructional placards applied to the product stay present and in good condition when doing maintenance or replacing components. If at any time the Warning labels become loose, unreadable or dislodged, replace the labels. If purchased in US/Canada, contact Customer Service for replacement labels. If purchased outside US/Canada, contact your local distributor for them.
- Do not try to change the design or functionality of the machine being serviced as this can adversely effect user safety and will void the warranty.
- Do not use the machine until all shrouds, instructions, warning labels and correct functionality have been verified and tested for correct performance.

**• SAVE THESE INSTRUCTIONS.**

**Tools Required (not included)**

#2 Phillips screwdriver

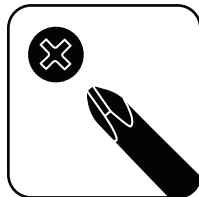

6mm hex wrench



# ⚠ DANGER

To reduce the risk of electrical shock or unsupervised usage of the equipment, always unplug the power cord from the wall outlet and wait 5 minutes before cleaning, maintaining or repairing this machine. Place the power cord in a secure location.

1. Unplug the power cord from the machine and wait 5 minutes. Place the power cord in a secure location.

2. Using a #2 Phillips screwdriver, remove the Handlebar Shrouds from the machine.

*NOTICE:* \* To assist with re-assembly, install the Inner Handlebar Shrouds first.

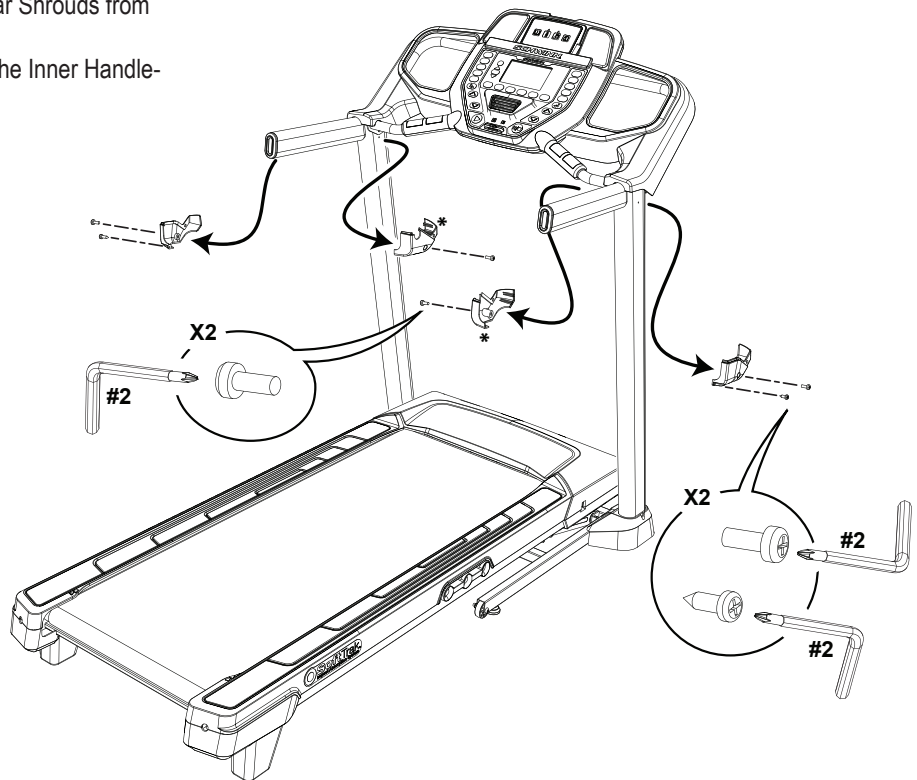

3. Using a 6mm hex wrench, remove the indicated hardware from the machine. Then safely lift the right side of the Console Assembly just enough to expose the Cable Connections. Disconnect the Cables and remove the Console Assembly.

**Note:** This step may require two people.

*NOTICE:* \* To assist with re-assembly, start this hardware first.

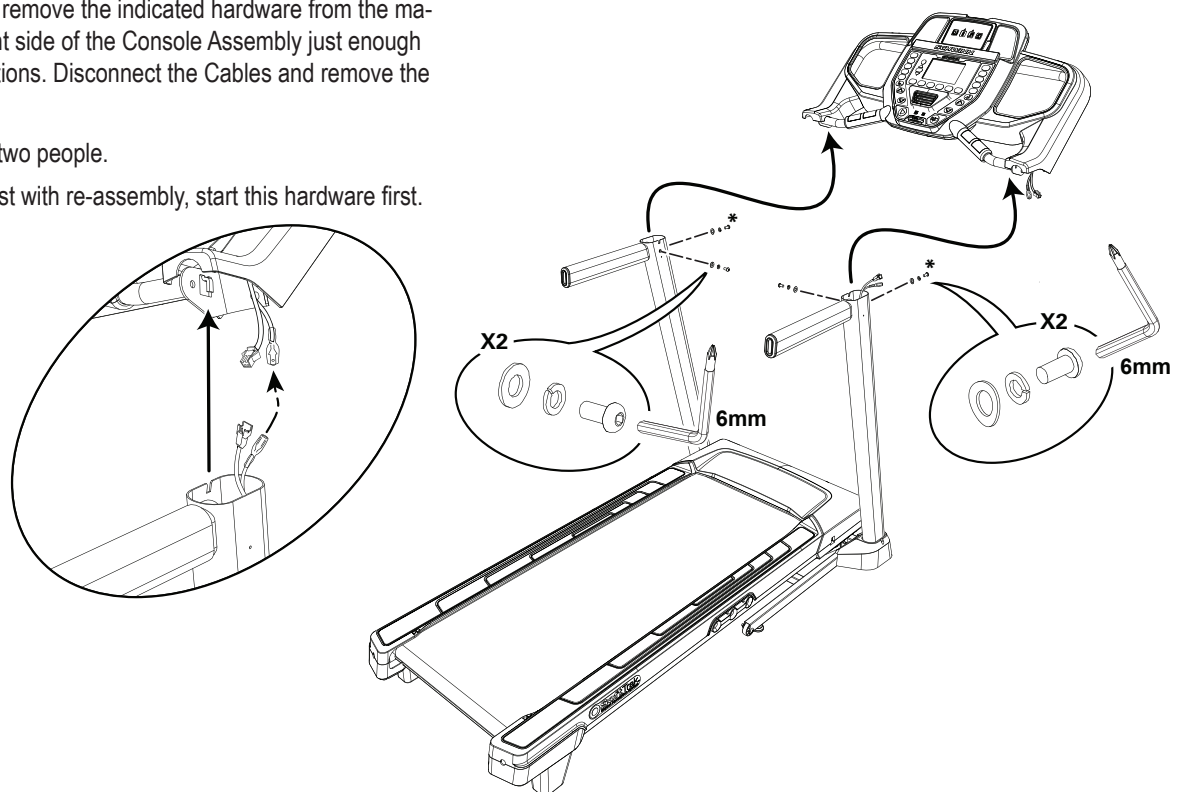



4. Using a #2 Phillips screwdriver remove the indicated screw from the Right Base Shroud and remove it.

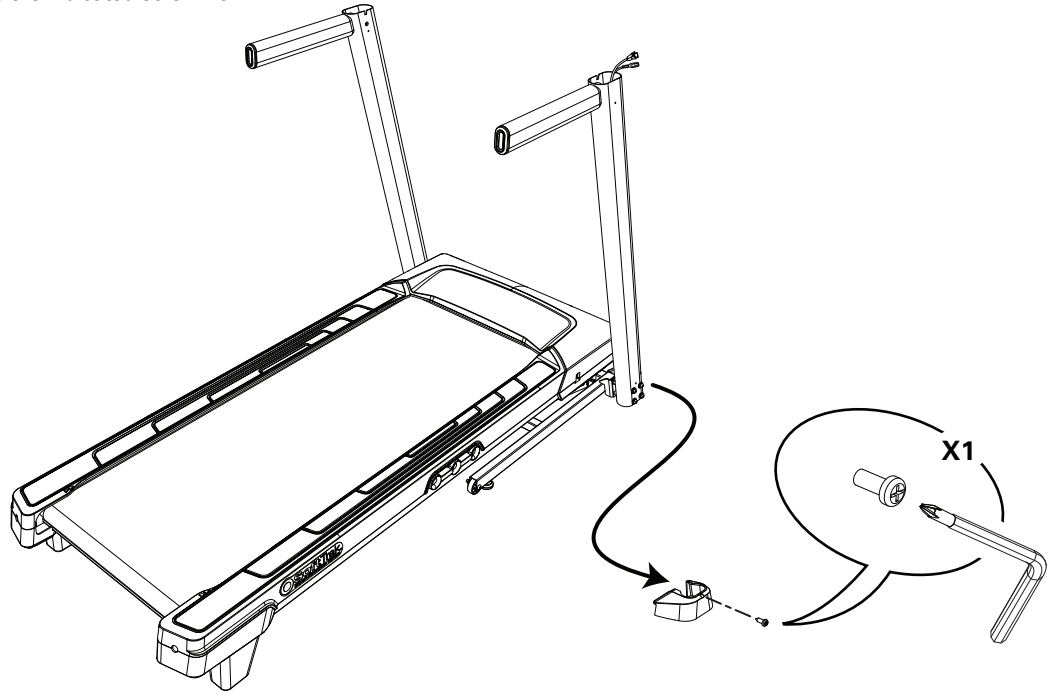

5. Make sure that there is safe clearance around, on and above the treadmill. Make sure there is no object to spill or cause blockage from the fully folded position.

**!** Be sure there is adequate height clearance for the raised deck.

6. Using the support bar found below the rear of the walking belt, lift the walking deck fully upward and engage the hydraulic lift. Be sure that the hydraulic lift is correctly locked in place. You will hear an audible click when the hydraulic lift shifts into the locked position.

**!** Use proper safety precautions and lifting techniques. Bend your knees and elbows, keep your back straight and pull up equally with both arms. Straighten your legs to lift. Make sure that your own physical strength is capable of lifting the walking deck until it engages the locking mechanism. Use a second person if necessary.

Do not use the walking belt or rear roller to lift the treadmill. These parts do not lock in place and can abruptly move. Injury to you or damage to the machine can occur.

7. Make sure that the locking mechanism is engaged. Carefully pull back on the walking deck and make sure that it does not move. When you do this, keep clear of movement path in case the treadmill lock is not properly engaged.

**!** Do not lean against the treadmill when it is folded. Do not put items on it that could cause it to become unstable or fall.

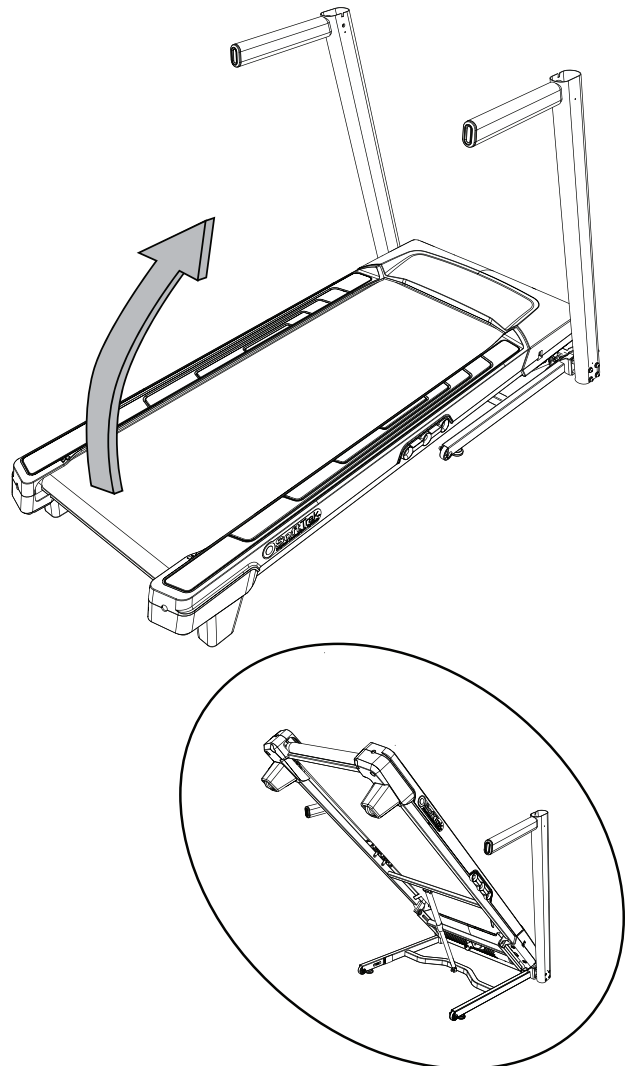

8. Using a 6mm hex wrench, remove the hardware that secures the Right Upright and slightly shift it away from the Frame Assembly. Carefully remove the I/O Cable from the old Right Upright, and dispose of the old Right Upright appropriately.

**Note:** Be prepared to support the weight of the Right Upright. This step may require two people. Do not pinch or cut the cables.

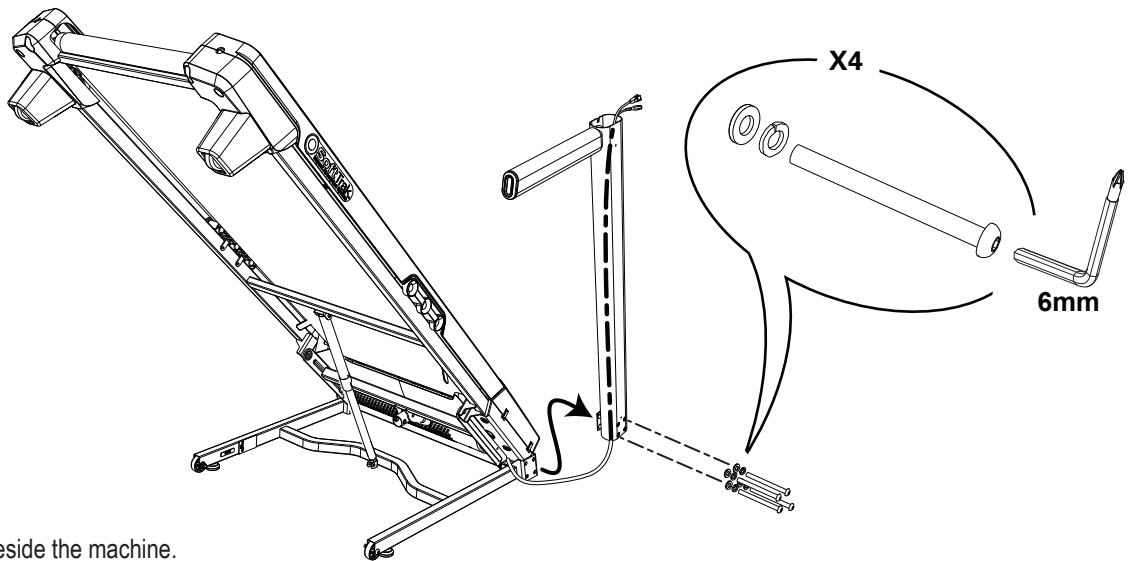

9. Place the new Right Upright beside the machine.

10. Connect the I/O Cable to the guide wire found at the lower part of the Right Upright. Gently route the I/O Cable through the new Right Upright.

**Note:** Be sure not to pinch or cut the cable when being routed.

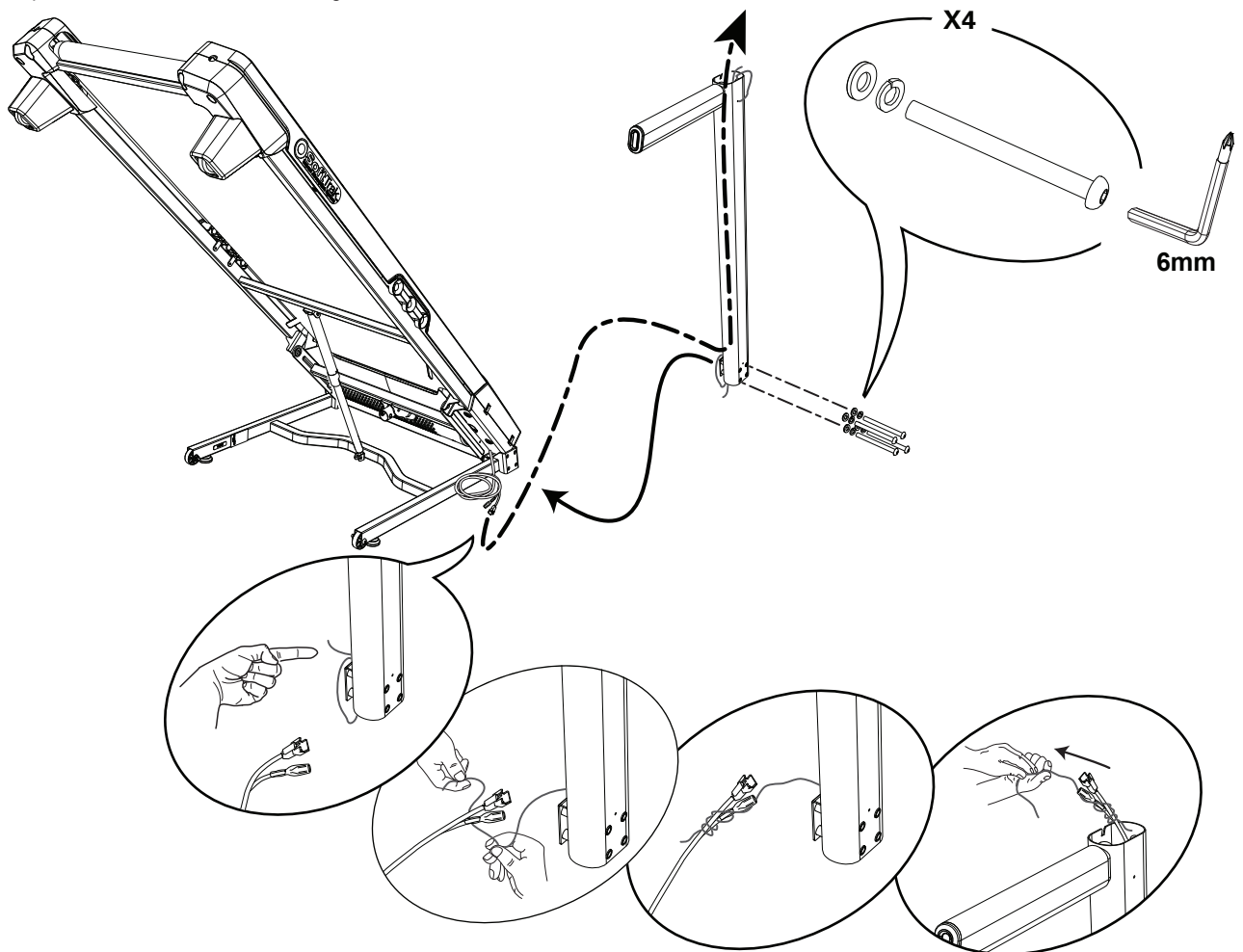

11. Using a 6mm hex wrench, secure the new Right Upright to the Frame Assembly.

12. Make sure there is sufficient space to lower the walking deck.

**⚠ Keep a minimum clearance behind the machine of 79" (2 m) and 19.7" (0.5 m) on each side. This is the recommended safe distance for access, movement and emergency dismounts from the machine.**

13. Make sure there is no object on or around the treadmill to spill or cause blockage from the fully unfolded position.

14. Slightly push the walking deck forward toward the console. With your foot lightly push the top part of the hydraulic lift forward until the locking tube releases and you can pull the walking deck away from the console. Hold up the rear of the walking deck, and move to the side of the machine.

**⚠ Keep clear of the movement path of the walking deck.**

15. The hydraulic lift is set up to drop gradually. Hold onto the walking deck until approximately 2/3 of the movement down. Lower the weight with your legs. Be aware that the walking deck can possibly drop quickly in the last part of the movement.



16. Using a #2 Phillips screwdriver, attach the Right Base Shroud to the Frame Assembly.

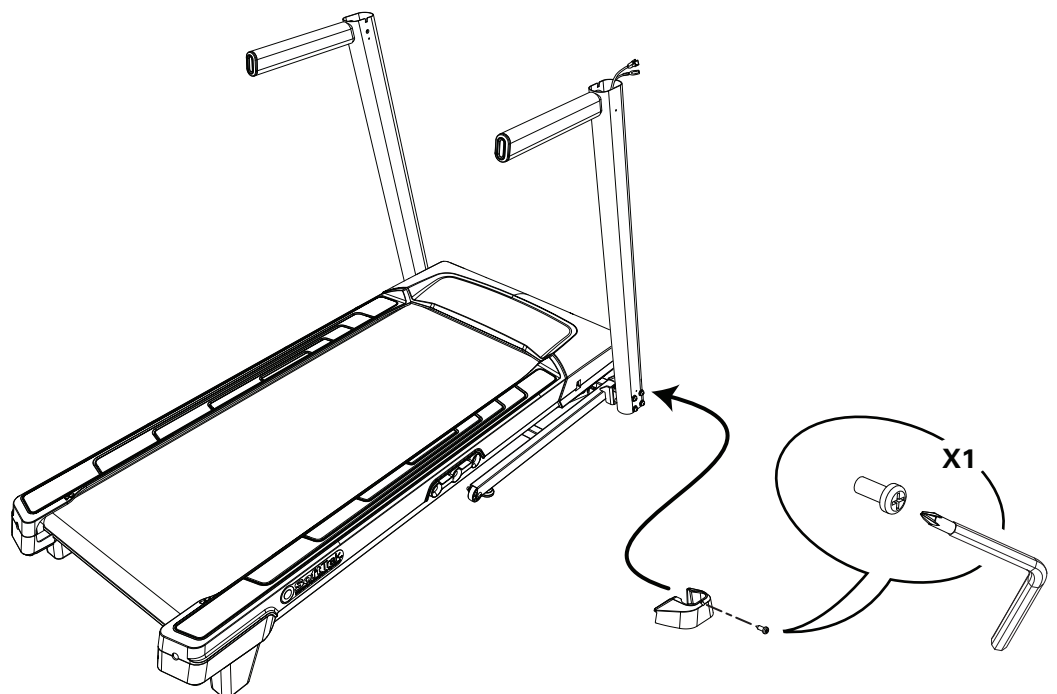

17. Connect the Cables and Attach the Console to Frame Assembly

**Note:** Do not pinch or cut the cables. Be sure the hooks on the Console are set into the notches of the Uprights. \*Install the front hardware first.

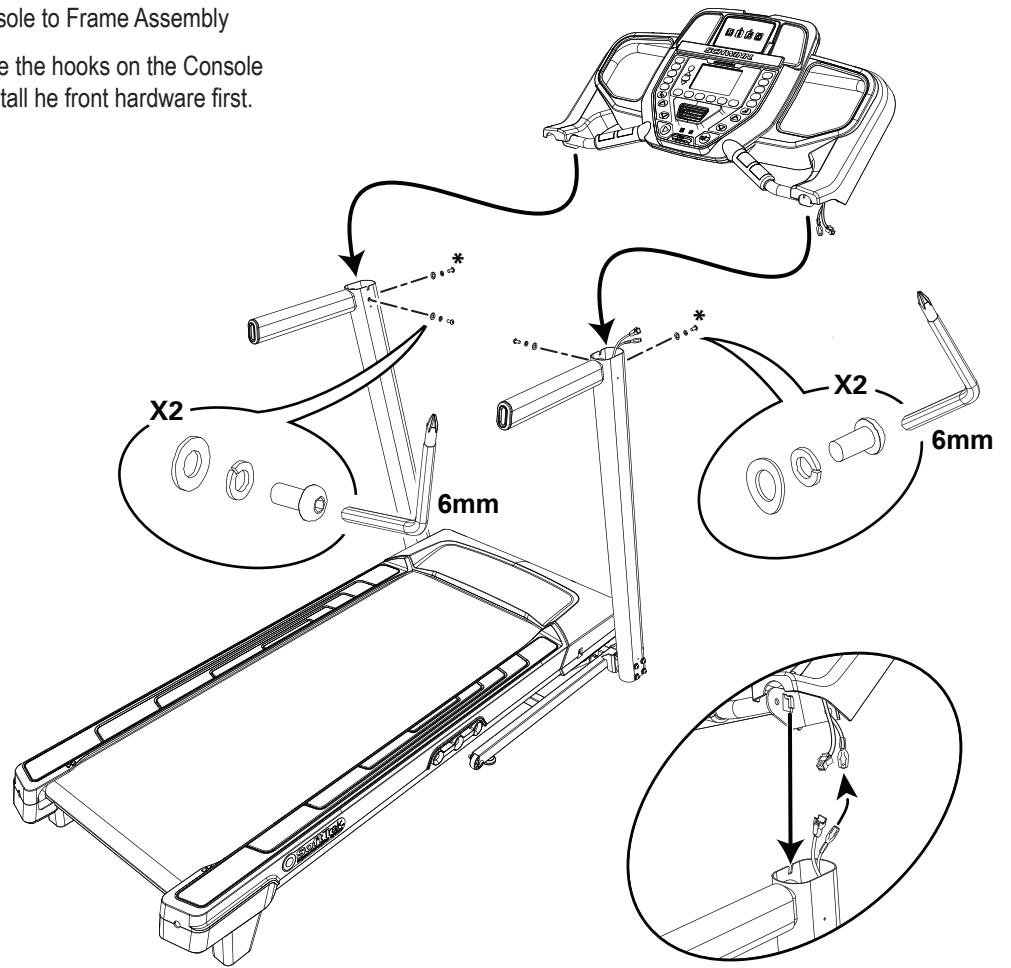

18. Re-install all remaining parts that were removed in reverse order.

19. Final Inspection

Inspect your machine to ensure that all hardware is tight and components are properly assembled.



**Do not use until the machine has been fully assembled and inspected for correct performance in accordance with the Owner's Manual.**



**NOTICE:** This document provides instructions for the replacement of the Rocker Switch on the Schwinn™ 810 / 510T machine.

If you need assistance, please contact Customer Service (if purchased in US/Canada) or your local distributor (if purchased outside US/Canada). To find your local distributor, go to: [www.nautilusinternational.com](http://www.nautilusinternational.com)

 This icon means a potentially hazardous situation which, if not avoided, could result in death or serious injury. Read and understand all Warnings on this machine.

Nautilus, Inc., [www.NautilusInc.com](http://www.NautilusInc.com), 5415 Centerpoint Parkway, Groveport, OH 43125 U.S.A. - Customer Service: North America (800) 605-3369, [csnls@nautilus.com](mailto:csnls@nautilus.com) | outside U.S. [www.nautilusinternational.com](http://www.nautilusinternational.com) | Printed in China | © 2019 Nautilus, Inc. | Schwinn and the Schwinn logo are trademarks owned or licensed by Nautilus, Inc., registered or otherwise protected by common law in the United States and other nations. | **ORIGINAL DOCUMENT - ENGLISH VERSION ONLY**

### Important Safety Instructions - Before servicing or using this equipment, obey the following warnings:

 This icon means a potentially hazardous situation which, if not avoided, could result in death or serious injury. Read and understand all Warnings on this machine.

** DANGER** To reduce the risk of electrical shock or unsupervised usage of the equipment, always unplug the power cord from the wall outlet and wait 5 minutes before cleaning, maintaining or repairing this machine. Place the power cord in a secure location.

- Read and understand the Part Replacement Procedure before working on the machine. Failure to obey the instructions and safety warnings could cause injury to the service technician or bystanders.
- Keep bystanders, children and pets away from the product being serviced at all times.
- Make sure that the repair is done in an appropriate work space away from foot traffic and exposure to bystanders.
- Disconnect all power and allow to sit for 5 minutes before you service this machine.
- Some components of the equipment can be heavy or awkward. Enlist the service of a second person when you do maintenance steps involving these components. Do not try to do heavy or awkward steps on your own.
- If replacement parts are necessary, use only genuine Nautilus replacement parts and hardware. Failure to use genuine replacement parts can cause a risk to users, keep the machine from operating correctly and will void the warranty.
- Be sure that all warning stickers and instructional placards applied to the product stay present and in good condition when doing maintenance or replacing components. If at any time the Warning labels become loose, unreadable or dislodged, replace the labels. If purchased in US/Canada, contact Customer Service for replacement labels. If purchased outside US/Canada, contact your local distributor for them.
- Do not try to change the design or functionality of the machine being serviced as this can adversely effect user safety and will void the warranty.
- Do not use the machine until all shrouds, instructions, warning labels and correct functionality have been verified and tested for correct performance.

• **SAVE THESE INSTRUCTIONS.**

#### Tools Required (not included)

#2 Phillips screwdriver



# ⚠ DANGER

To reduce the risk of electrical shock or unsupervised usage of the equipment, always unplug the power cord from the wall outlet and wait 5 minutes before cleaning, maintaining or repairing this machine. Place the power cord in a secure location.

1. Unplug the power cord from the machine and wait 5 minutes. Place the power cord in a secure location.

2. Using a #2 Phillips screwdriver remove the 4 indicated screws from the Motor Cover.



3. Using the support bar found below the rear of the walking belt, lift the walking deck fully upward and engage the hydraulic lift. Be sure that the hydraulic lift is correctly locked in place. You will hear an audible click when the hydraulic lift shifts into the locked position.

**⚠ Use proper safety precautions and lifting techniques. Bend your knees and elbows, keep your back straight and pull up equally with both arms. Straighten your legs to lift. Make sure that your own physical strength is capable of lifting the walking deck until it engages the locking mechanism. Use a second person if necessary.**

**Do not use the walking belt or rear roller to lift the treadmill. These parts do not lock in place and can abruptly move. Injury to you or damage to the machine can occur.**



4. Make sure that the locking mechanism is engaged. Carefully pull back on the walking deck and make sure that it does not move. When you do this, keep clear of movement path in case the treadmill lock is not properly engaged.

**⚠ Do not lean against the treadmill when it is folded. Do not put items on it that could cause it to become unstable or fall.**



5. Using a #2 Phillips screwdriver remove the 2 indicated screws from the Motor Cover and remove it.



6. Make sure there is sufficient space to lower the walking deck.

**!** Keep a minimum clearance behind the machine of 79" (2 m) and 19.7" (0.5 m) on each side. This is the recommended safe distance for access, movement and emergency dismounts from the machine.

7. Make sure there is no object on or around the treadmill to spill or cause blockage from the fully unfolded position.

8. Slightly push the walking deck forward toward the console. With your foot lightly push the top part of the hydraulic lift forward until the locking tube releases and you can pull the walking deck away from the console. Hold up the rear of the walking deck, and move to the side of the machine.

**!** Keep clear of the movement path of the walking deck.

9. The hydraulic lift is set up to drop gradually. Hold onto the walking deck until approximately 2/3 of the movement down. Lower the weight with your legs. Be aware that the walking deck can possibly drop quickly in the last part of the movement.





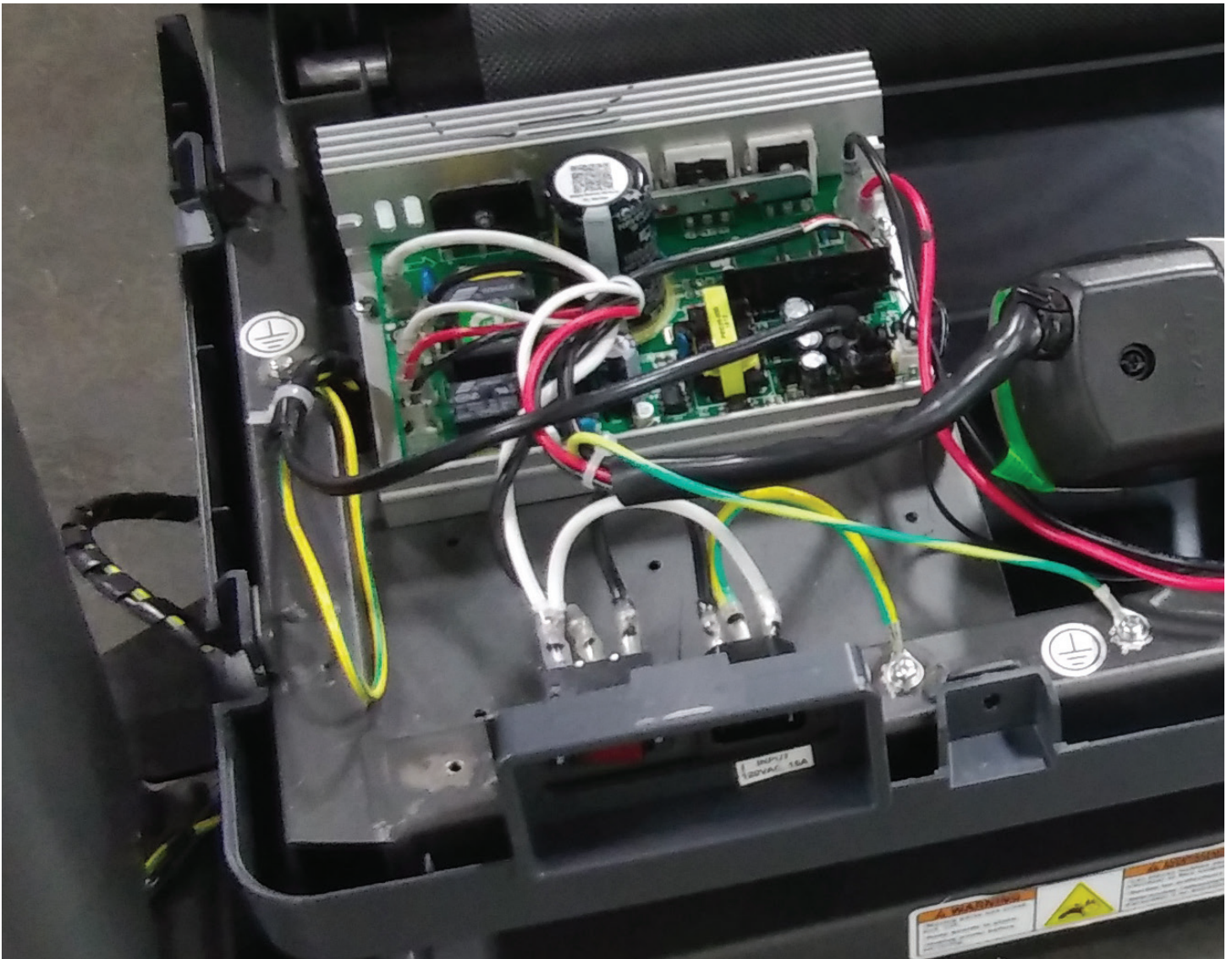
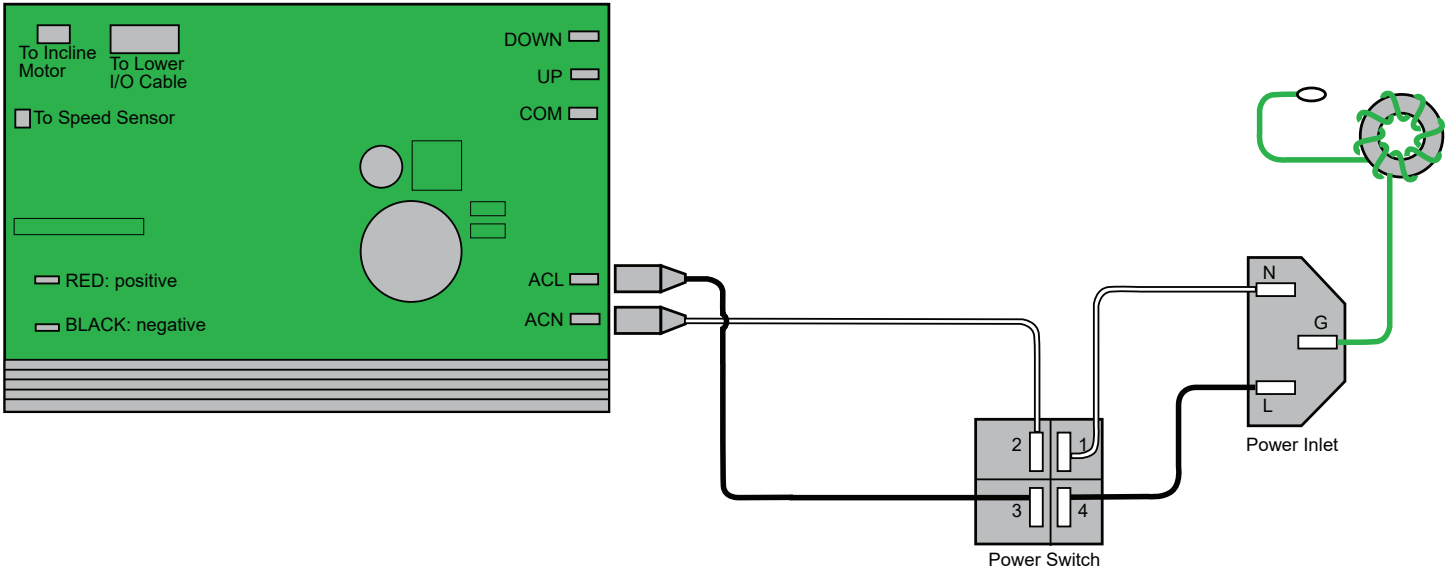



10. Release the Securing Clips from the Rocker Switch and remove it from the Frame.

11. Remove the connectors and attach them to the new Rocker Switch. Be sure to attach them in the same locations on the new Rocker Switch.

12. Insert the new Rocker Switch into the Frame being sure the Securing Clips engage.

**Note:** Do not pinch or cut any cables.

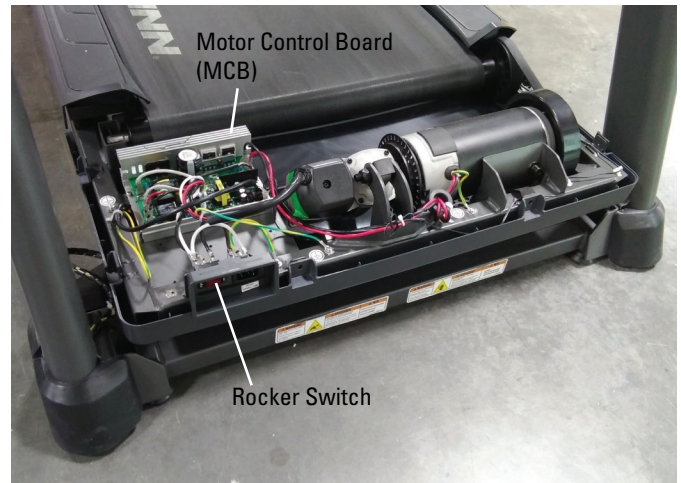

13. Re-install all remaining parts that were removed in reverse order.

#### 14. Final Inspection

Inspect your machine to ensure that all hardware is tight and components are properly assembled.



**Do not use until the machine has been fully assembled and inspected for correct performance in accordance with the Owner's Manual.**

**NOTICE:** This document provides instructions for the replacement of the Side Rail on the Schwinn™ 810 / 510T machine.

If you need assistance, please contact Customer Service (if purchased in US/Canada) or your local distributor (if purchased outside US/Canada). To find your local distributor, go to: [www.nautilusinternational.com](http://www.nautilusinternational.com)

**!** This icon means a potentially hazardous situation which, if not avoided, could result in death or serious injury. Read and understand all Warnings on this machine.

Nautilus, Inc., [www.NautilusInc.com](http://www.NautilusInc.com), 5415 Centerpoint Parkway, Groveport, OH 43125 U.S.A. - Customer Service: North America (800) 605-3369, [csnls@nautilus.com](mailto:csnls@nautilus.com) | outside U.S. [www.nautilusinternational.com](http://www.nautilusinternational.com) | Printed in China | © 2019 Nautilus, Inc. | Schwinn and the Schwinn logo are trademarks owned or licensed by Nautilus, Inc., registered or otherwise protected by common law in the United States and other nations. | **ORIGINAL DOCUMENT - ENGLISH VERSION ONLY**

**Important Safety Instructions - Before servicing or using this equipment, obey the following warnings:**

**!** This icon means a potentially hazardous situation which, if not avoided, could result in death or serious injury. Read and understand all Warnings on this machine.

**! DANGER** To reduce the risk of electrical shock or unsupervised usage of the equipment, always unplug the power cord from the wall outlet and wait 5 minutes before cleaning, maintaining or repairing this machine. Place the power cord in a secure location.

- Read and understand the Part Replacement Procedure before working on the machine. Failure to obey the instructions and safety warnings could cause injury to the service technician or bystanders.
- Keep bystanders, children and pets away from the product being serviced at all times.
- Make sure that the repair is done in an appropriate work space away from foot traffic and exposure to bystanders.
- Disconnect all power and allow to sit for 5 minutes before you service this machine.
- Some components of the equipment can be heavy or awkward. Enlist the service of a second person when you do maintenance steps involving these components. Do not try to do heavy or awkward steps on your own.
- If replacement parts are necessary, use only genuine Nautilus replacement parts and hardware. Failure to use genuine replacement parts can cause a risk to users, keep the machine from operating correctly and will void the warranty.
- Be sure that all warning stickers and instructional placards applied to the product stay present and in good condition when doing maintenance or replacing components. If at any time the Warning labels become loose, unreadable or dislodged, replace the labels. If purchased in US/Canada, contact Customer Service for replacement labels. If purchased outside US/Canada, contact your local distributor for them.
- Do not try to change the design or functionality of the machine being serviced as this can adversely effect user safety and will void the warranty.
- Do not use the machine until all shrouds, instructions, warning labels and correct functionality have been verified and tested for correct performance.

**• SAVE THESE INSTRUCTIONS.**

**Tools Required (not included)**

#2 Phillips screwdriver

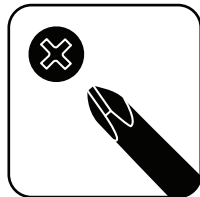

## **⚠ DANGER**

To reduce the risk of electrical shock or unsupervised usage of the equipment, always unplug the power cord from the wall outlet and wait 5 minutes before cleaning, maintaining or repairing this machine. Place the power cord in a secure location.

1. Unplug the power cord from the machine and wait 5 minutes. Place the power cord in a secure location.

2. Make sure that there is safe clearance around, on and above the treadmill. Make sure there is no object to spill or cause blockage from the fully folded position.

**⚠ Be sure there is adequate height clearance for the raised deck.**

3. Using the support bar found below the rear of the walking belt, lift the walking deck fully upward and engage the hydraulic lift. Be sure that the hydraulic lift is correctly locked in place. You will hear an audible click when the hydraulic lift shifts into the locked position.

**⚠ Use proper safety precautions and lifting techniques. Bend your knees and elbows, keep your back straight and pull up equally with both arms. Straighten your legs to lift. Make sure that your own physical strength is capable of lifting the walking deck until it engages the locking mechanism. Use a second person if necessary.**

**Do not use the walking belt or rear roller to lift the treadmill. These parts do not lock in place and can abruptly move. Injury to you or damage to the machine can occur.**

4. Make sure that the locking mechanism is engaged. Carefully pull back on the walking deck and make sure that it does not move. When you do this, keep clear of movement path in case the treadmill lock is not properly engaged.

**⚠ Do not lean against the treadmill when it is folded. Do not put items on it that could cause it to become unstable or fall.**



5. Using a #2 Phillips screwdriver, remove the indicated screw (with arrows) from the Rear Roller Cover.

6. Remove the Rear Roller Covers from the machine.

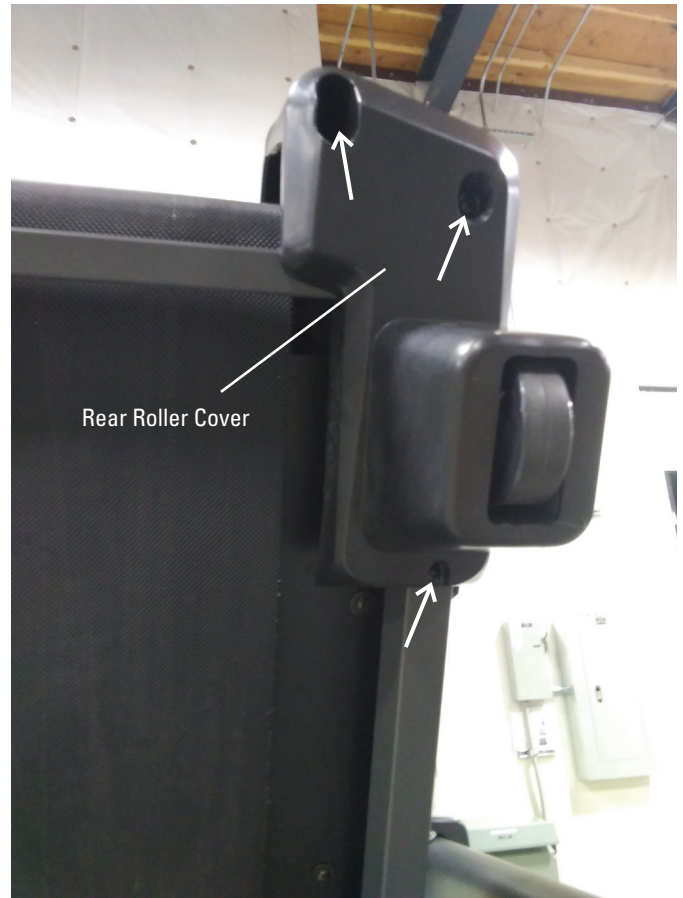

7. Using a #2 Phillips screwdriver, remove the 6 indicated screws from below the Walking Deck that attach the Side Rail.

8. Remove the Side Rail from the Walking Deck.

9. Installation of the new Side Rail is the reverse procedure.





10. Make sure there is sufficient space to lower the walking deck.

**!** Keep a minimum clearance behind the machine of 79" (2 m) and 19.7" (0.5 m) on each side. This is the recommended safe distance for access, movement and emergency dismounts from the machine.

11. Make sure there is no object on or around the treadmill to spill or cause blockage from the fully unfolded position.

12. Slightly push the walking deck forward toward the console. With your foot lightly push the top part of the hydraulic lift forward until the locking tube releases and you can pull the walking deck away from the console. Hold up the rear of the walking deck, and move to the side of the machine.

**!** Keep clear of the movement path of the walking deck.

13. The hydraulic lift is set up to drop gradually. Hold onto the walking deck until approximately 2/3 of the movement down. Lower the weight with your legs. Be aware that the walking deck can possibly drop quickly in the last part of the movement.

14. Final Inspection

Inspect your machine to ensure that all hardware is tight and components are properly assembled.

**!** Do not use until the machine has been fully assembled and inspected for correct performance in accordance with the Owner's Manual.



**NOTICE:** This document provides instructions for the replacement of the Speed Sensor Assembly on the Schwinn™ 810 / 510T machine.

If you need assistance, please contact Customer Service (if purchased in US/Canada) or your local distributor (if purchased outside US/Canada). To find your local distributor, go to: [www.nautilusinternational.com](http://www.nautilusinternational.com)

**!** This icon means a potentially hazardous situation which, if not avoided, could result in death or serious injury. Read and understand all Warnings on this machine.

Nautilus, Inc., [www.NautilusInc.com](http://www.NautilusInc.com), 5415 Centerpoint Parkway, Groveport, OH 43125 U.S.A. - Customer Service: North America (800) 605-3369, [csnls@nautilus.com](mailto:csnls@nautilus.com) | outside U.S. [www.nautilusinternational.com](http://www.nautilusinternational.com) | Printed in China | © 2019 Nautilus, Inc. | Schwinn and the Schwinn logo are trademarks owned or licensed by Nautilus, Inc., registered or otherwise protected by common law in the United States and other nations. | **ORIGINAL DOCUMENT - ENGLISH VERSION ONLY**

**Important Safety Instructions - Before servicing or using this equipment, obey the following warnings:**

**!** This icon means a potentially hazardous situation which, if not avoided, could result in death or serious injury. Read and understand all Warnings on this machine.

**! DANGER** To reduce the risk of electrical shock or unsupervised usage of the equipment, always unplug the power cord from the wall outlet and wait 5 minutes before cleaning, maintaining or repairing this machine. Place the power cord in a secure location.

- Read and understand the Part Replacement Procedure before working on the machine. Failure to obey the instructions and safety warnings could cause injury to the service technician or bystanders.
- Keep bystanders, children and pets away from the product being serviced at all times.
- Make sure that the repair is done in an appropriate work space away from foot traffic and exposure to bystanders.
- Disconnect all power and allow to sit for 5 minutes before you service this machine.
- Some components of the equipment can be heavy or awkward. Enlist the service of a second person when you do maintenance steps involving these components. Do not try to do heavy or awkward steps on your own.
- If replacement parts are necessary, use only genuine Nautilus replacement parts and hardware. Failure to use genuine replacement parts can cause a risk to users, keep the machine from operating correctly and will void the warranty.
- Be sure that all warning stickers and instructional placards applied to the product stay present and in good condition when doing maintenance or replacing components. If at any time the Warning labels become loose, unreadable or dislodged, replace the labels. If purchased in US/Canada, contact Customer Service for replacement labels. If purchased outside US/Canada, contact your local distributor for them.
- Do not try to change the design or functionality of the machine being serviced as this can adversely effect user safety and will void the warranty.
- Do not use the machine until all shrouds, instructions, warning labels and correct functionality have been verified and tested for correct performance.

**• SAVE THESE INSTRUCTIONS.**

**Tools Required (not included)**

#2 Phillips screwdriver

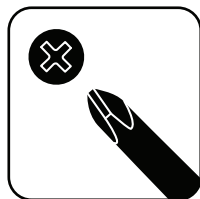

Something to cut Zip-Ties

Replacement Zip-Ties ( x4 )



# ⚠ DANGER

To reduce the risk of electrical shock or unsupervised usage of the equipment, always unplug the power cord from the wall outlet and wait 5 minutes before cleaning, maintaining or repairing this machine. Place the power cord in a secure location.

1. Unplug the power cord from the machine and wait 5 minutes. Place the power cord in a secure location.

2. Using a #2 Phillips screwdriver remove the 4 indicated screws from the Motor Cover.



3. Using the support bar found below the rear of the walking belt, lift the walking deck fully upward and engage the hydraulic lift. Be sure that the hydraulic lift is correctly locked in place. You will hear an audible click when the hydraulic lift shifts into the locked position.

**⚠ Use proper safety precautions and lifting techniques. Bend your knees and elbows, keep your back straight and pull up equally with both arms. Straighten your legs to lift. Make sure that your own physical strength is capable of lifting the walking deck until it engages the locking mechanism. Use a second person if necessary.**

**Do not use the walking belt or rear roller to lift the treadmill. These parts do not lock in place and can abruptly move. Injury to you or damage to the machine can occur.**

4. Make sure that the locking mechanism is engaged. Carefully pull back on the walking deck and make sure that it does not move. When you do this, keep clear of movement path in case the treadmill lock is not properly engaged.

**⚠ Do not lean against the treadmill when it is folded. Do not put items on it that could cause it to become unstable or fall.**



5. Using a #2 Phillips screwdriver remove the 2 indicated screws from the Motor Cover and remove it.



6. Make sure there is sufficient space to lower the walking deck.

**!** Keep a minimum clearance behind the machine of 79" (2 m) and 19.7" (0.5 m) on each side. This is the recommended safe distance for access, movement and emergency dismounts from the machine.

7. Make sure there is no object on or around the treadmill to spill or cause blockage from the fully unfolded position.

8. Slightly push the walking deck forward toward the console. With your foot lightly push the top part of the hydraulic lift forward until the locking tube releases and you can pull the walking deck away from the console. Hold up the rear of the walking deck, and move to the side of the machine.

**!** Keep clear of the movement path of the walking deck.



9. The hydraulic lift is set up to drop gradually. Hold onto the walking deck until approximately 2/3 of the movement down. Lower the weight with your legs. Be aware that the walking deck can possibly drop quickly in the last part of the movement.



10. Using a #2 Phillips screwdriver, remove the 2 indicated screws (by arrow) that attach the Speed Sensor to the Frame near the Drive Pulley.

**Note:** Be sure to observe the distance from the Speed Sensor to the Drive Pulley. This distance affects the effectiveness of the Speed Sensor and will be used for the re-assembly process.

11. Remove the Speed Sensor Cable from the Clips that secure it to the Frame.

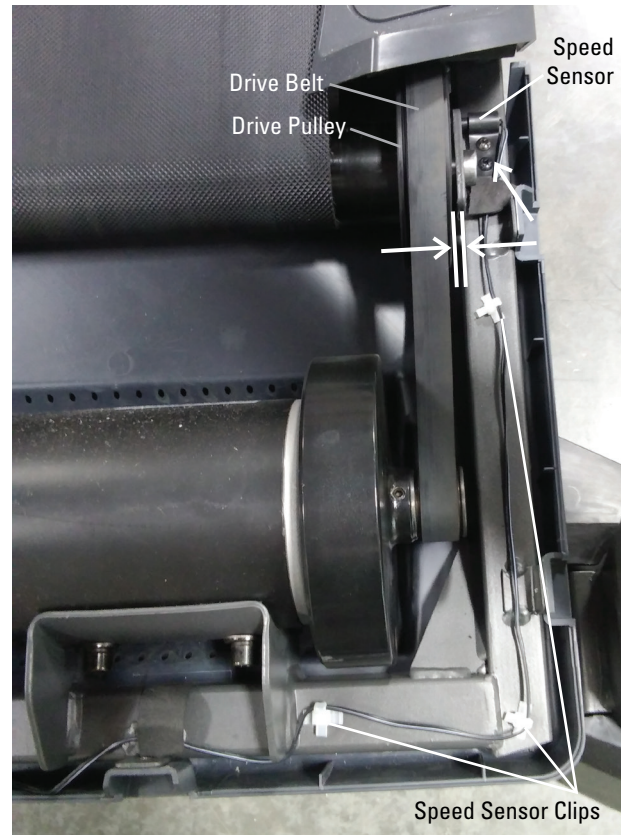
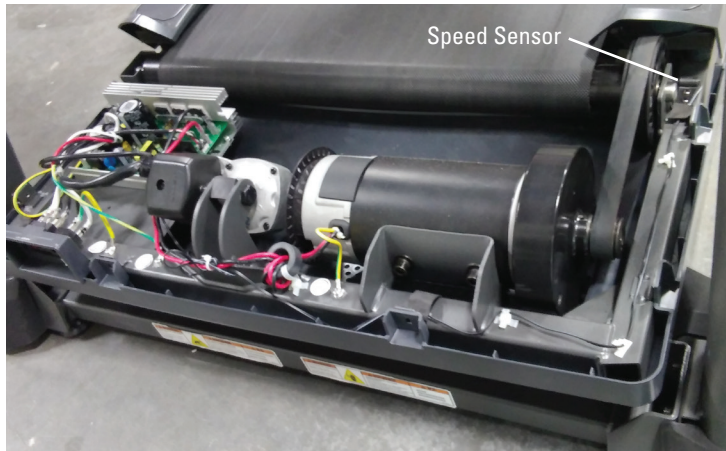

12. Remove the Speed Sensor Connector from the Motor Control Board.

**Note:** See following page for Wiring Diagram and close up image of Motor Control Board.

13. Attach the new Speed Sensor Connector to the Motor Control Board.

14. Route the new Speed Sensor Cable along the Frame and secure it with the Speed Sensor Clips.

15. Using a #2 Phillips screwdriver, attach the new Speed Sensor and adjust it to be the same distance as the old Sensor from the Drive Pulley.

16. Re-install all remaining parts that were removed in reverse order.

17. Final Inspection

Inspect your machine to ensure that all hardware is tight and components are properly assembled.



**Do not use until the machine has been fully assembled and inspected for correct performance in accordance with the Owner's Manual.**

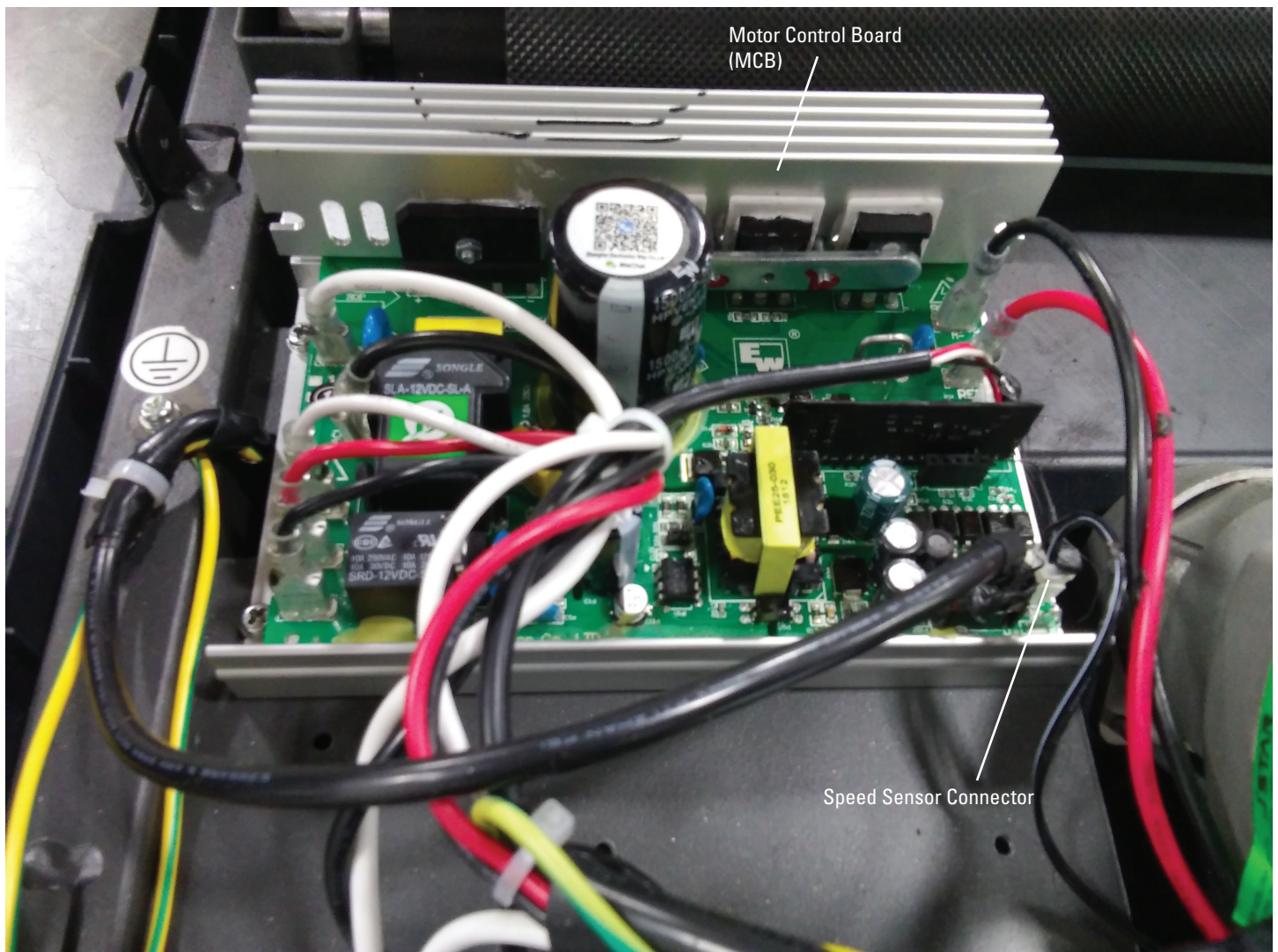
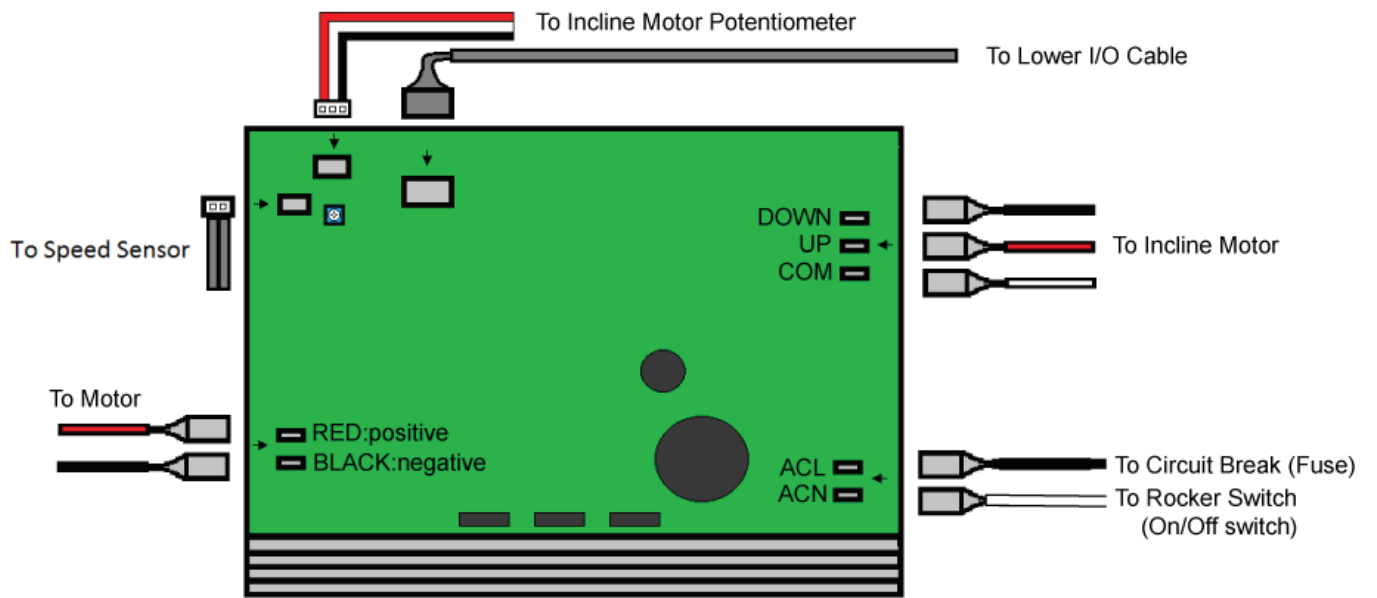

**NOTICE:** This document provides instructions for the replacement of the Transport Wheel on the Schwinn™ 810 / 510T machine.

If you need assistance, please contact Customer Service (if purchased in US/Canada) or your local distributor (if purchased outside US/Canada). To find your local distributor, go to: [www.nautilusinternational.com](http://www.nautilusinternational.com)

 This icon means a potentially hazardous situation which, if not avoided, could result in death or serious injury. Read and understand all Warnings on this machine.

Nautilus, Inc., [www.NautilusInc.com](http://www.NautilusInc.com), 5415 Centerpoint Parkway, Groveport, OH 43125 U.S.A. - Customer Service: North America (800) 605-3369, [csnls@nautilus.com](mailto:csnls@nautilus.com) | outside U.S. [www.nautilusinternational.com](http://www.nautilusinternational.com) | Printed in China | © 2019 Nautilus, Inc. | Schwinn and the Schwinn logo are trademarks owned or licensed by Nautilus, Inc., registered or otherwise protected by common law in the United States and other nations. | **ORIGINAL DOCUMENT - ENGLISH VERSION ONLY**

**Important Safety Instructions - Before servicing or using this equipment, obey the following warnings:**

 This icon means a potentially hazardous situation which, if not avoided, could result in death or serious injury. Read and understand all Warnings on this machine.

** DANGER** To reduce the risk of electrical shock or unsupervised usage of the equipment, always unplug the power cord from the wall outlet and wait 5 minutes before cleaning, maintaining or repairing this machine. Place the power cord in a secure location.

- Read and understand the Part Replacement Procedure before working on the machine. Failure to obey the instructions and safety warnings could cause injury to the service technician or bystanders.
- Keep bystanders, children and pets away from the product being serviced at all times.
- Make sure that the repair is done in an appropriate work space away from foot traffic and exposure to bystanders.
- Disconnect all power and allow to sit for 5 minutes before you service this machine.
- Some components of the equipment can be heavy or awkward. Enlist the service of a second person when you do maintenance steps involving these components. Do not try to do heavy or awkward steps on your own.
- If replacement parts are necessary, use only genuine Nautilus replacement parts and hardware. Failure to use genuine replacement parts can cause a risk to users, keep the machine from operating correctly and will void the warranty.
- Be sure that all warning stickers and instructional placards applied to the product stay present and in good condition when doing maintenance or replacing components. If at any time the Warning labels become loose, unreadable or dislodged, replace the labels. If purchased in US/Canada, contact Customer Service for replacement labels. If purchased outside US/Canada, contact your local distributor for them.
- Do not try to change the design or functionality of the machine being serviced as this can adversely effect user safety and will void the warranty.
- Do not use the machine until all shrouds, instructions, warning labels and correct functionality have been verified and tested for correct performance.

• **SAVE THESE INSTRUCTIONS.**

**Tools Required (not included)**

6mm hex wrench



13mm wrench





# ⚠ DANGER

To reduce the risk of electrical shock or unsupervised usage of the equipment, always unplug the power cord from the wall outlet and wait 5 minutes before cleaning, maintaining or repairing this machine. Place the power cord in a secure location.

1. Unplug the power cord from the machine and wait 5 minutes. Place the power cord in a secure location.

2. Make sure that there is safe clearance around, on and above the treadmill. Make sure there is no object to spill or cause blockage from the fully folded position.

⚠ Be sure there is adequate height clearance for the raised deck.

3. Using the support bar found below the rear of the walking belt, lift the walking deck fully upward and engage the hydraulic lift. Be sure that the hydraulic lift is correctly locked in place. You will hear an audible click when the hydraulic lift shifts into the locked position.

⚠ Use proper safety precautions and lifting techniques. Bend your knees and elbows, keep your back straight and pull up equally with both arms. Straighten your legs to lift. Make sure that your own physical strength is capable of lifting the walking deck until it engages the locking mechanism. Use a second person if necessary.

Do not use the walking belt or rear roller to lift the treadmill. These parts do not lock in place and can abruptly move. Injury to you or damage to the machine can occur.

4. Make sure that the locking mechanism is engaged. Carefully pull back on the walking deck and make sure that it does not move. When you do this, keep clear of movement path in case the treadmill lock is not properly engaged.

⚠ Do not lean against the treadmill when it is folded. Do not put items on it that could cause it to become unstable or fall.





5. Using a 13mm wrench and a 6mm hex wrench, remove the hardware indicated from the Transport Wheel.

6. Remove the old Transport Wheel, and attach the new Transport Wheel.

7. Re-install all remaining parts that were removed in reverse order.

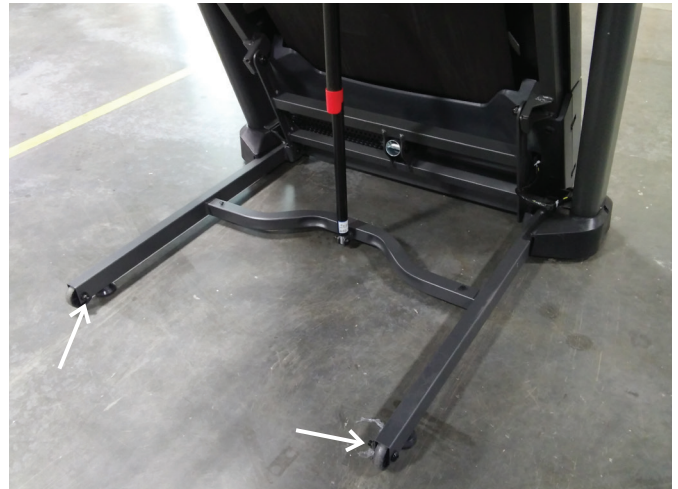

8. Make sure there is sufficient space to lower the walking deck.

**⚠ Keep a minimum clearance behind the machine of 79" (2 m) and 19.7" (0.5 m) on each side. This is the recommended safe distance for access, movement and emergency dismounts from the machine.**

9. Make sure there is no object on or around the treadmill to spill or cause blockage from the fully unfolded position.

10. Slightly push the walking deck forward toward the console. With your foot lightly push the top part of the hydraulic lift forward until the locking tube releases and you can pull the walking deck away from the console. Hold up the rear of the walking deck, and move to the side of the machine.

**⚠ Keep clear of the movement path of the walking deck.**

11. The hydraulic lift is set up to drop gradually. Hold onto the walking deck until approximately 2/3 of the movement down. Lower the weight with your legs. Be aware that the walking deck can possibly drop quickly in the last part of the movement.



12. Final Inspection

Inspect your machine to ensure that all hardware is tight and components are properly assembled.

**⚠ Do not use until the machine has been fully assembled and inspected for correct performance in accordance with the Owner's Manual.**

**NOTICE:** This document provides instructions for the replacement of the Walking Belt on the Schwinn™ 810 / 510T machine.

If you need assistance, please contact Customer Service (if purchased in US/Canada) or your local distributor (if purchased outside US/Canada). To find your local distributor, go to: [www.nautilusinternational.com](http://www.nautilusinternational.com)

**!** This icon means a potentially hazardous situation which, if not avoided, could result in death or serious injury. Read and understand all Warnings on this machine.

Nautilus, Inc., [www.NautilusInc.com](http://www.NautilusInc.com), 5415 Centerpoint Parkway, Groveport, OH 43125 U.S.A. - Customer Service: North America (800) 605-3369, [csnls@nautilus.com](mailto:csnls@nautilus.com) | outside U.S. [www.nautilusinternational.com](http://www.nautilusinternational.com) | Printed in China | © 2019 Nautilus, Inc. | Schwinn and the Schwinn logo are trademarks owned or licensed by Nautilus, Inc., registered or otherwise protected by common law in the United States and other nations. | **ORIGINAL DOCUMENT - ENGLISH VERSION ONLY**

**Important Safety Instructions - Before servicing or using this equipment, obey the following warnings:**

**!** This icon means a potentially hazardous situation which, if not avoided, could result in death or serious injury. Read and understand all Warnings on this machine.

**DANGER** To reduce the risk of electrical shock or unsupervised usage of the equipment, always unplug the power cord from the wall outlet and wait 5 minutes before cleaning, maintaining or repairing this machine. Place the power cord in a secure location.

- Read and understand the Part Replacement Procedure before working on the machine. Failure to obey the instructions and safety warnings could cause injury to the service technician or bystanders.
- Keep bystanders, children and pets away from the product being serviced at all times.
- Make sure that the repair is done in an appropriate work space away from foot traffic and exposure to bystanders.
- Disconnect all power and allow to sit for 5 minutes before you service this machine.
- Some components of the equipment can be heavy or awkward. Enlist the service of a second person when you do maintenance steps involving these components. Do not try to do heavy or awkward steps on your own.
- If replacement parts are necessary, use only genuine Nautilus replacement parts and hardware. Failure to use genuine replacement parts can cause a risk to users, keep the machine from operating correctly and will void the warranty.
- Be sure that all warning stickers and instructional placards applied to the product stay present and in good condition when doing maintenance or replacing components. If at any time the Warning labels become loose, unreadable or dislodged, replace the labels. If purchased in US/Canada, contact Customer Service for replacement labels. If purchased outside US/Canada, contact your local distributor for them.
- Do not try to change the design or functionality of the machine being serviced as this can adversely effect user safety and will void the warranty.
- Do not use the machine until all shrouds, instructions, warning labels and correct functionality have been verified and tested for correct performance.

**• SAVE THESE INSTRUCTIONS.**

**Tools Required (not included)**

#2 Phillips screwdriver

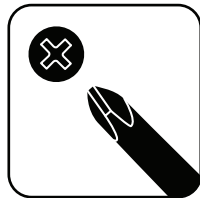

8300 Silicone Spray or Lube-N-Walk® Treadmill Lubrication Kit

6mm hex wrench



13mm wrench



# ⚠ DANGER

To reduce the risk of electrical shock or unsupervised usage of the equipment, always unplug the power cord from the wall outlet and wait 5 minutes before cleaning, maintaining or repairing this machine. Place the power cord in a secure location.

1. Unplug the power cord from the machine and wait 5 minutes. Place the power cord in a secure location.

2. Using a 6mm hex wrench, loosen the Walking Belt with the Adjustment Bolts found on both Rear Roller Covers. Loosen the Adjustment Bolts only until the Walking Belt slides past the Rollers freely. Do not loosen the Adjustment Bolts too much or the Rear Roller may detach.

**Note:** Be sure to record the number of turns of the Adjustment Bolts it takes to loosen the Walking Belt. This will assist with reassembly.

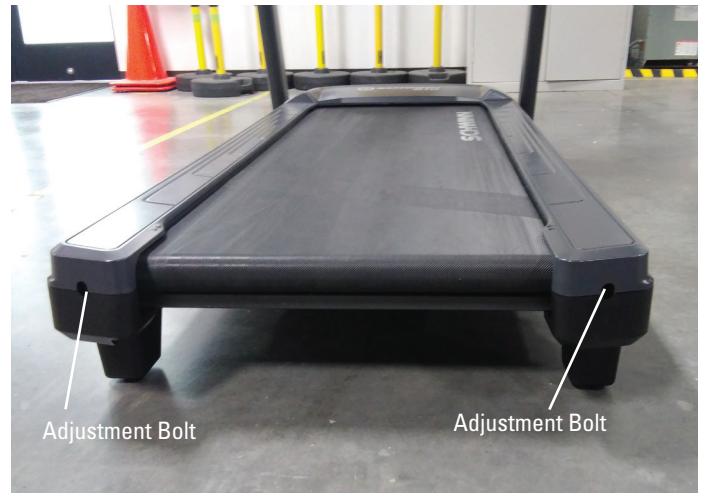

3. Using a #2 Phillips screwdriver remove the 4 indicated screws from the Motor Cover.



4. Make sure that there is safe clearance around, on and above the treadmill. Make sure there is no object to spill or cause blockage from the fully folded position.

**⚠ Be sure there is adequate height clearance for the raised deck.**

5. Using the support bar found below the rear of the walking belt, lift the walking deck fully upward and engage the hydraulic lift. Be sure that the hydraulic lift is correctly locked in place. You will hear an audible click when the hydraulic lift shifts into the locked position.

**⚠ Use proper safety precautions and lifting techniques. Bend your knees and elbows, keep your back straight and pull up equally with both arms. Straighten your legs to lift. Make sure that your own physical strength is capable of lifting the walking deck until it engages the locking mechanism. Use a second person if necessary.**

**Do not use the walking belt or rear roller to lift the treadmill. These parts do not lock in place and can abruptly move. Injury to you or damage to the machine can occur.**





6. Make sure that the locking mechanism is engaged. Carefully pull back on the walking deck and make sure that it does not move. When you do this, keep clear of movement path in case the treadmill lock is not properly engaged.

**⚠ Do not lean against the treadmill when it is folded. Do not put items on it that could cause it to become unstable or fall.**

7. Using a #2 Phillips screwdriver remove the 2 indicated screws from the Motor Cover and remove it.



8. Using a #2 Phillips screwdriver, remove the indicated screw (with arrows) from the Rear Roller Cover.

9. Remove the Rear Roller Covers from the machine.

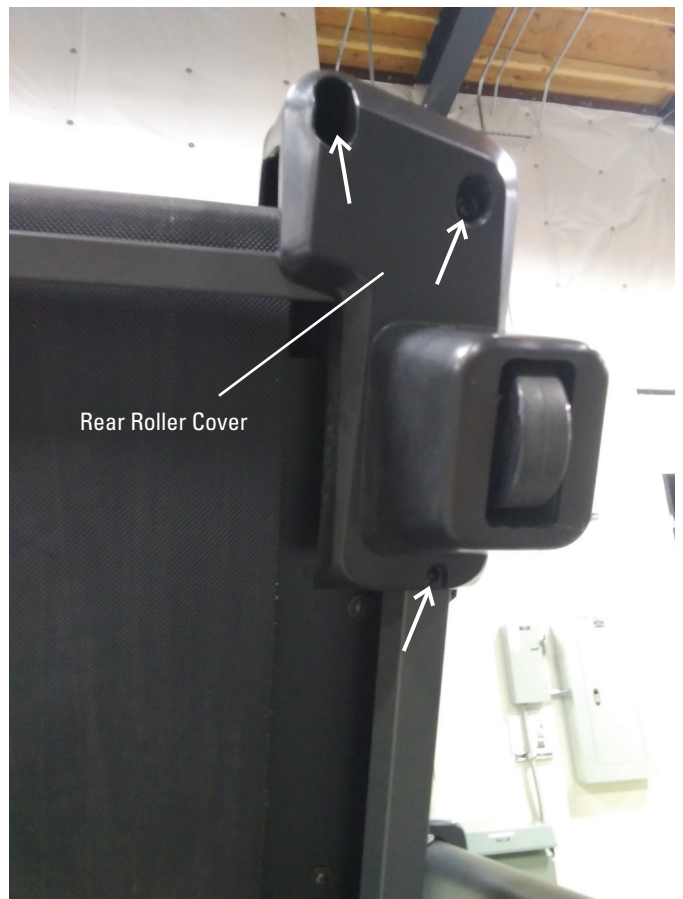



10. Using a #2 Phillips screwdriver, remove the 6 indicated screws from below the Walking Deck that attach the Right Side Rail.

11. Remove the Right Side Rail from the Walking Deck.



12. Using a #2 Phillips screwdriver remove the 2 screws (indicated by arrow) from the Right Deck Suspensions.

13. Remove the Right Deck Suspension.



14. Make sure there is sufficient space to lower the walking deck.

**!** Keep a minimum clearance behind the machine of 79" (2 m) and 19.7" (0.5 m) on each side. This is the recommended safe distance for access, movement and emergency dismounts from the machine.

15. Make sure there is no object on or around the treadmill to spill or cause blockage from the fully unfolded position.

16. Slightly push the walking deck forward toward the console. With your foot lightly push the top part of the hydraulic lift forward until the locking tube releases and you can pull the walking deck away from the console. Hold up the rear of the walking deck, and move to the side of the machine.

**!** Keep clear of the movement path of the walking deck.

17. The hydraulic lift is set up to drop gradually. Hold onto the walking deck until approximately 2/3 of the movement down. Lower the weight with your legs. Be aware that the walking deck can possibly drop quickly in the last part of the movement.

18. Be sure to observe the distance from the Speed Sensor to the Drive Pulley. This distance affects the effectiveness of the Speed Sensor, and can easily be shifted accidentally during replacement procedures.

19. Using a 6mm hex wrench, remove the indicated screw from the Front Roller.

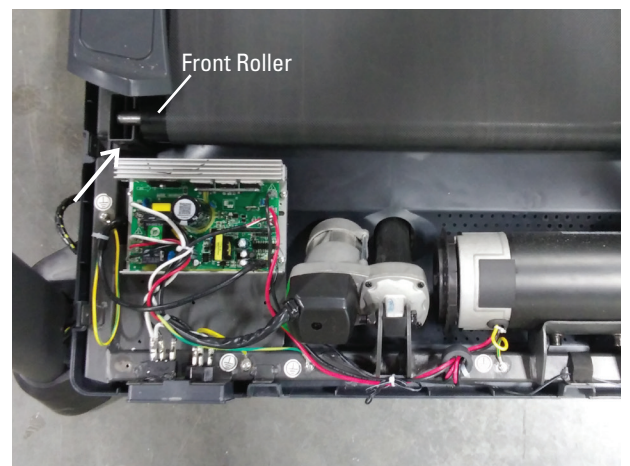
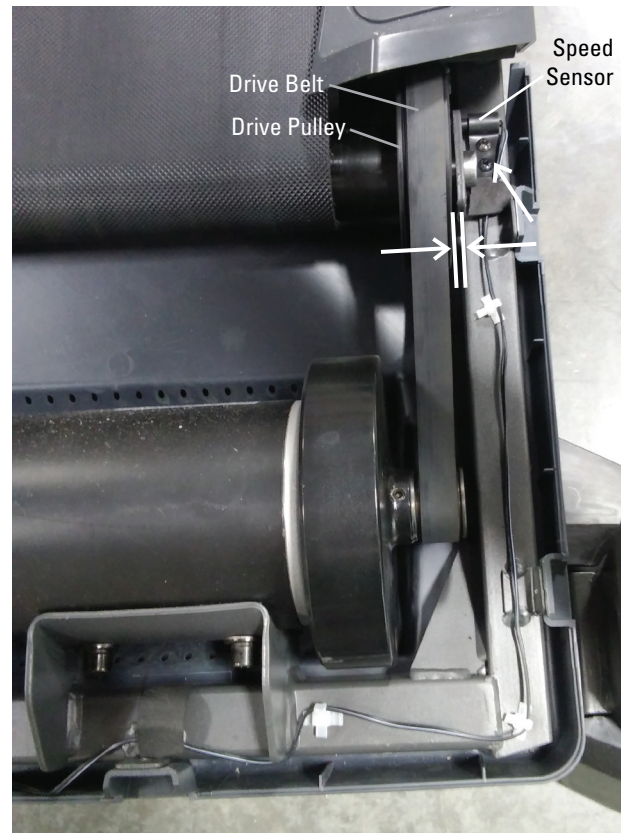



20. Using a 6mm hex wrench, remove the 2 indicated screws from the Deck.



**Note:** Your machine may not match the provided images exactly.

21. Lift and pivot the Front Roller out of the Frame, and slide it out of the Walking Belt. This will free the Drive Belt from the Front Roller.

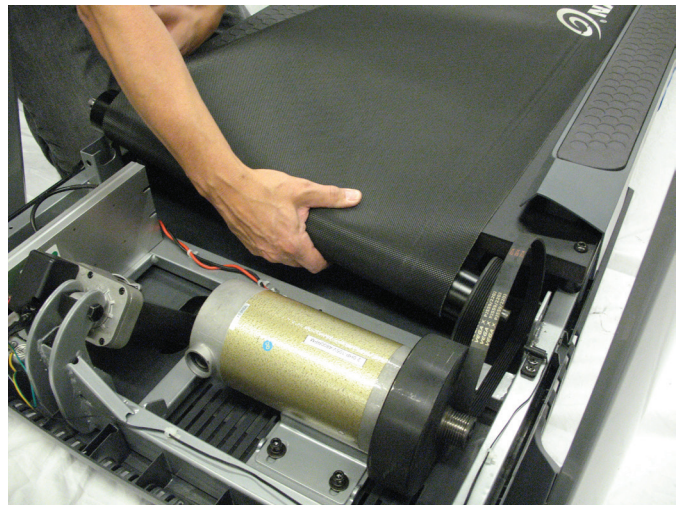

22. Using a 6mm hex wrench, finish removing the Adjustment Bolt from the Rear Roller.

**Note:** Be sure to record the number of turns of the Adjustment Bolt it takes to remove it. This will assist with reassembly.

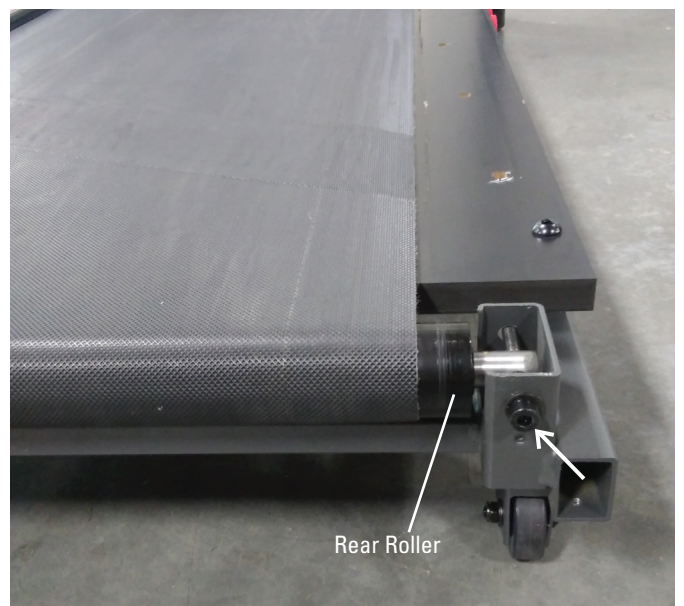

23. Slide the old Walking Belt off of the Deck, and replace with a new Walking Belt.

24. Slide the Front Roller into the new Walking Belt in the same orientation.

25. Using a 6mm hex wrench, re-attach the Adjustment Bolt to the Rear Roller.

**Note:** Be sure to only tighten it the number of turns it took to loosen the Walking Belt.

26. Using a 6mm hex wrench, re-install the 2 screws to the Deck.

27. Loop the Drive Belt around the Front Roller. Insert the end of the Front Roller with the Drive Pulley into the Frame and pivot the other end into the Bracket.

28. Using a 6mm hex wrench, attach the Front Roller to the Bracket.

**Note:** Tighten the hardware until the Front Roller is centered in the Bracket.

29. Loop the Drive Belt around the Motor Pulley. Start the Drive Belt on the Drive Pulley and roll it in a clockwise motion. Be sure the Belt does not come off of the Motor Pulley.

 **Keep fingers out of any pinch opportunities when turning the Pulleys.**

30. Roll the Drive Pulley clockwise until the Drive Belt is fully installed. Continue to roll the Belt forward while adding side pressure with fingers to align as necessary.

31. Inspect the Speed Sensor to see if it has been moved during the procedure. If necessary, adjust it to be the appropriate distance from the Drive Pulley.

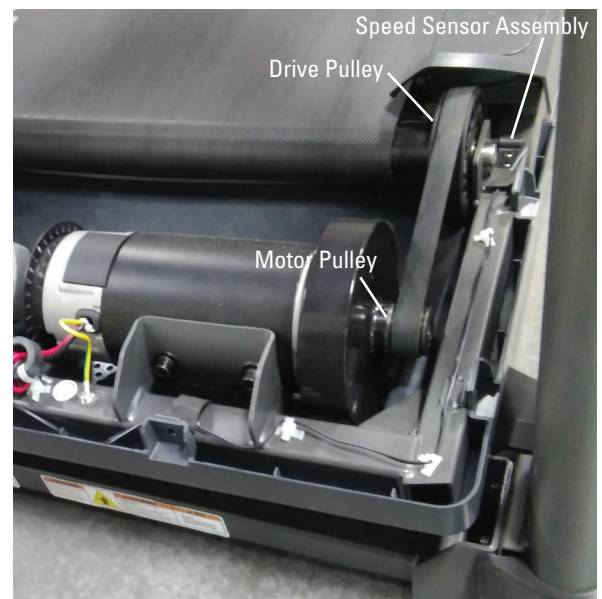
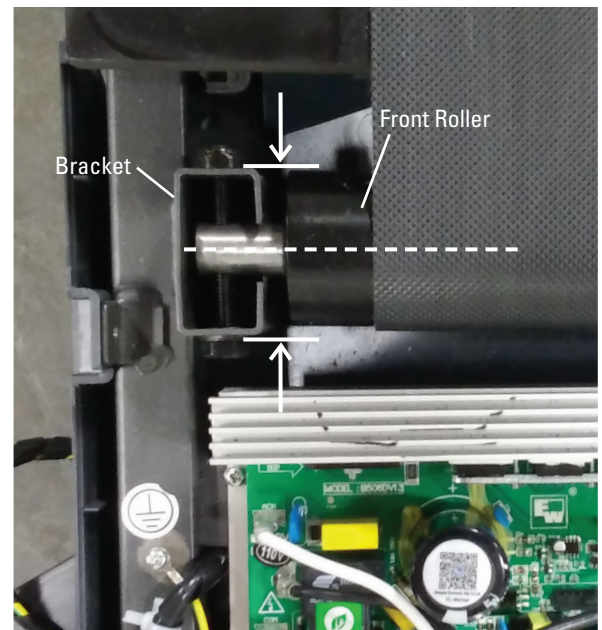
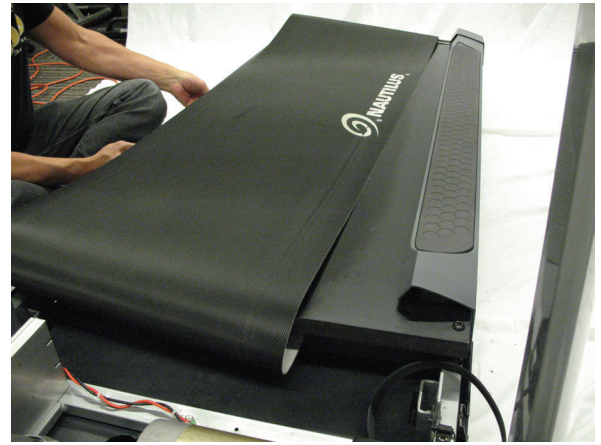



32. Re-install all remaining parts that were removed in reverse order.

33. Inspect the surface material below the Treadmill. If the surface material is difficult to clean or could be damaged by silicone lubricant, place absorbent material (such as cardboard or newspaper) below the length of the Walking Deck.

34. Make sure that there is safe clearance around, on and above the treadmill. Make sure there is no object to spill or cause blockage from the fully folded position.

**⚠ Be sure there is adequate height clearance for the raised deck.**

35. Using the support bar found below the rear of the walking belt, lift the walking deck fully upward and engage the hydraulic lift. Be sure that the hydraulic lift is correctly locked in place. You will hear an audible click when the hydraulic lift shifts into the locked position.

**⚠ Use proper safety precautions and lifting techniques. Bend your knees and elbows, keep your back straight and pull up equally with both arms. Straighten your legs to lift. Make sure that your own physical strength is capable of lifting the walking deck until it engages the locking mechanism. Use a second person if necessary.**



**Do not use the walking belt or rear roller to lift the treadmill. These parts do not lock in place and can abruptly move. Injury to you or damage to the machine can occur.**

36. Make sure that the locking mechanism is engaged. Carefully pull back on the walking deck and make sure that it does not move. When you do this, keep clear of movement path in case the treadmill lock is not properly engaged.

**⚠ Do not lean against the treadmill when it is folded. Do not put items on it that could cause it to become unstable or fall.**

37. Apply a few drops of lubricant to the inner surface of the belt for the entire width of the belt. A very thin layer of silicone lubricant on the entire deck below the belt is desired.

*NOTICE:* Always use a 100% silicone lubricant. Do not use a degreaser like WD-40® as this could seriously impact performance. We can recommend that you use the following:

- 8300 Silicone Spray, available at most Hardware and Auto Parts stores.
- Lube-N-Walk® Treadmill Lubrication Kit, available from your local specialty fitness dealer or Nautilus, Inc.

38. Manually rotate the belt 1/2 of the length of the belt and apply lubricant again.

39. Make sure there is sufficient space to lower the walking deck.

**⚠ Keep a minimum clearance behind the machine of 79" (2 m) and 19.7" (0.5 m) on each side. This is the recommended safe distance for access, movement and emergency dismounts from the machine.**

40. Make sure there is no object on or around the treadmill to spill or cause blockage from the fully unfolded position.

41. Slightly push the walking deck forward toward the console. With your foot lightly push the top part of the hydraulic lift forward until the locking tube releases and you can pull the walking deck away from the console. Hold up the rear of the walking deck, and move to the side of the machine.

**⚠ Keep clear of the movement path of the walking deck.**

42. The hydraulic lift is set up to drop gradually. Hold onto the walking deck until approximately 2/3 of the movement down. Lower the weight with your legs. Be aware that the walking deck can possibly drop quickly in the last part of the movement.

**⚠ If you used spray lubricant, wait 5 minutes before turning on power to the machine to allow the aerosol to dissipate.**



43. Attach the power cord and turn on the Treadmill by flipping the power switch to ON.

44. Start the belt at the slowest speed and stand well behind the machine. Let the belt operate for approximately 15 seconds. Notice if the Walking Belt needs to be adjusted so it runs centered on the machine.

**⚠ Be sure not to touch the walking belt or step on the power cord. Keep bystanders, children and pets away from the machine you are servicing at all times.**

45. If the Walking Belt needs to be adjusted, use a 6mm hex wrench on the side the belt should move away from and rotate the Adjustment Bolt a 1/4 turn clock-wise.

46. Allow the Walking Belt to adjust to the new tension by allowing it to run a couple seconds.

47. Repeat steps 45 and 46 until the Walking Belt is centered.

48. Switch off your machine.

49. Take care to clean up any excess lubricant from the deck.

**⚠ To decrease the possibility of slipping, be sure the deck area is free from grease or oil. Clean off any excess oil from the machine surfaces.**

50. Final Inspection

Inspect your machine to ensure that all hardware is tight and components are properly assembled.

**⚠ Do not use until the machine has been fully assembled and inspected for correct performance in accordance with the Owner's Manual.**

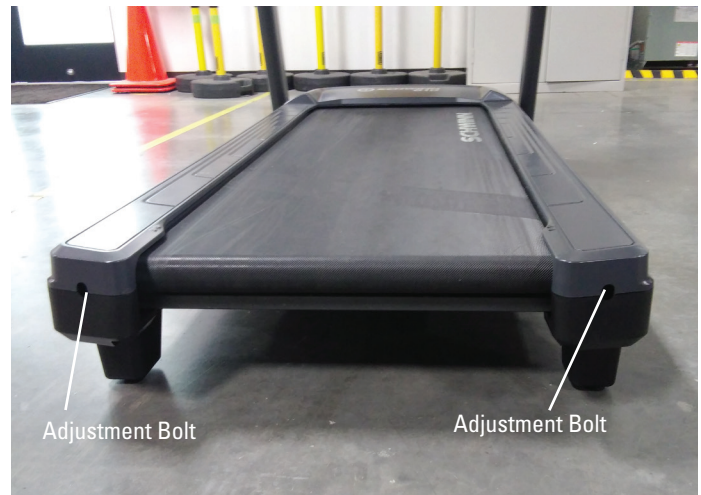

**NOTICE:** This document provides instructions for the replacement of the Walking Deck on the Schwinn™ 810 / 510T machine.

If you need assistance, please contact Customer Service (if purchased in US/Canada) or your local distributor (if purchased outside US/Canada). To find your local distributor, go to: [www.nautilusinternational.com](http://www.nautilusinternational.com)

 This icon means a potentially hazardous situation which, if not avoided, could result in death or serious injury. Read and understand all Warnings on this machine.

Nautilus, Inc., [www.NautilusInc.com](http://www.NautilusInc.com), 5415 Centerpoint Parkway, Groveport, OH 43125 U.S.A. - Customer Service: North America (800) 605-3369, [csnls@nautilus.com](mailto:csnls@nautilus.com) | outside U.S. [www.nautilusinternational.com](http://www.nautilusinternational.com) | Printed in China | © 2019 Nautilus, Inc. | Schwinn and the Schwinn logo are trademarks owned or licensed by Nautilus, Inc., registered or otherwise protected by common law in the United States and other nations. | **ORIGINAL DOCUMENT - ENGLISH VERSION ONLY**

**Important Safety Instructions - Before servicing or using this equipment, obey the following warnings:**

 This icon means a potentially hazardous situation which, if not avoided, could result in death or serious injury. Read and understand all Warnings on this machine.

** DANGER** To reduce the risk of electrical shock or unsupervised usage of the equipment, always unplug the power cord from the wall outlet and wait 5 minutes before cleaning, maintaining or repairing this machine. Place the power cord in a secure location.

- Read and understand the Part Replacement Procedure before working on the machine. Failure to obey the instructions and safety warnings could cause injury to the service technician or bystanders.
- Keep bystanders, children and pets away from the product being serviced at all times.
- Make sure that the repair is done in an appropriate work space away from foot traffic and exposure to bystanders.
- Disconnect all power and allow to sit for 5 minutes before you service this machine.
- Some components of the equipment can be heavy or awkward. Enlist the service of a second person when you do maintenance steps involving these components. Do not try to do heavy or awkward steps on your own.
- If replacement parts are necessary, use only genuine Nautilus replacement parts and hardware. Failure to use genuine replacement parts can cause a risk to users, keep the machine from operating correctly and will void the warranty.
- Be sure that all warning stickers and instructional placards applied to the product stay present and in good condition when doing maintenance or replacing components. If at any time the Warning labels become loose, unreadable or dislodged, replace the labels. If purchased in US/Canada, contact Customer Service for replacement labels. If purchased outside US/Canada, contact your local distributor for them.
- Do not try to change the design or functionality of the machine being serviced as this can adversely effect user safety and will void the warranty.
- Do not use the machine until all shrouds, instructions, warning labels and correct functionality have been verified and tested for correct performance.

**• SAVE THESE INSTRUCTIONS.**

**Tools Required (not included)**

#2 Phillips screwdriver

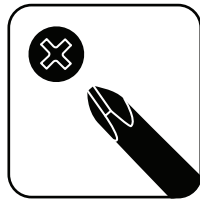

6mm hex wrench





# ⚠ DANGER

To reduce the risk of electrical shock or unsupervised usage of the equipment, always unplug the power cord from the wall outlet and wait 5 minutes before cleaning, maintaining or repairing this machine. Place the power cord in a secure location.

1. Unplug the power cord from the machine and wait 5 minutes. Place the power cord in a secure location.

2. Using a 6mm hex wrench, loosen the Walking Belt with the Adjustment Bolts found on both Rear Roller Covers. Loosen the Adjustment Bolts only until the Walking Belt slides past the Rollers freely. Do not loosen the Adjustment Bolts too much or the Rear Roller may detach.

**Note:** Be sure to record the number of turns of the Adjustment Bolts it takes to loosen the Walking Belt. This will assist with reassembly.

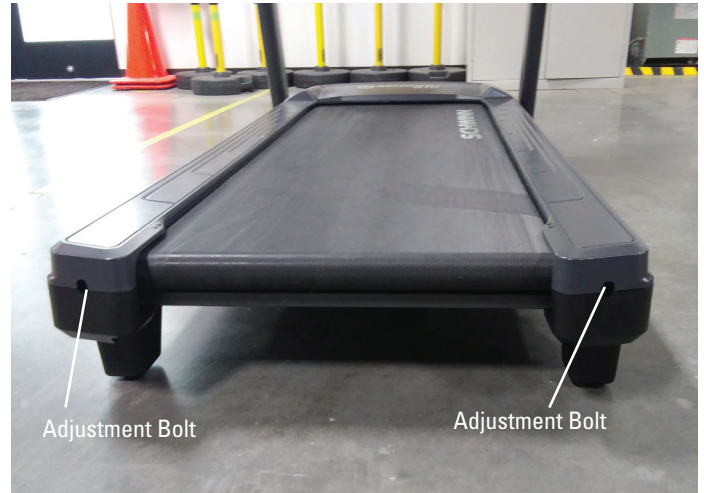

3. Using a #2 Phillips screwdriver remove the 4 indicated screws from the Motor Cover.



4. Make sure that there is safe clearance around, on and above the treadmill. Make sure there is no object to spill or cause blockage from the fully folded position.

**⚠ Be sure there is adequate height clearance for the raised deck.**

5. Using the support bar found below the rear of the walking belt, lift the walking deck fully upward and engage the hydraulic lift. Be sure that the hydraulic lift is correctly locked in place. You will hear an audible click when the hydraulic lift shifts into the locked position.

**⚠ Use proper safety precautions and lifting techniques. Bend your knees and elbows, keep your back straight and pull up equally with both arms. Straighten your legs to lift. Make sure that your own physical strength is capable of lifting the walking deck until it engages the locking mechanism. Use a second person if necessary.**

**Do not use the walking belt or rear roller to lift the treadmill. These parts do not lock in place and can abruptly move. Injury to you or damage to the machine can occur.**





6. Make sure that the locking mechanism is engaged. Carefully pull back on the walking deck and make sure that it does not move. When you do this, keep clear of movement path in case the treadmill lock is not properly engaged.

**⚠ Do not lean against the treadmill when it is folded. Do not put items on it that could cause it to become unstable or fall.**

7. Using a #2 Phillips screwdriver remove the 2 indicated screws from the Motor Cover and remove it.



8. Using a #2 Phillips screwdriver, remove the indicated screw (with arrows) from the Right Rear Roller Cover.

9. Repeat the previous Step to the Left Rear Roller Cover.

10. Remove the Rear Roller Covers from the machine.

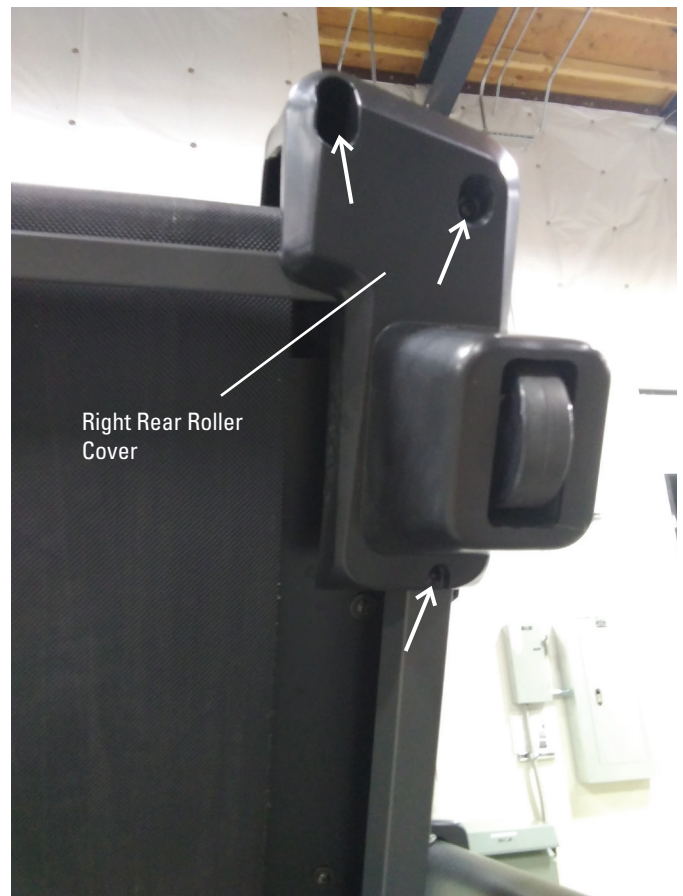

11. Using a #2 Phillips screwdriver, remove the 6 indicated screws from below the Walking Deck that attach the Right Side Rail.

12. Remove the Right Side Rail from the Walking Deck.

13. Repeat the previous two Steps to the Left side of the machine.



14. Using a #2 Phillips screwdriver remove the 2 screws (indicated by arrow) from the Right Deck Suspensions.

15. Remove the Right Deck Suspension.

16. Repeat the previous two Steps to the Left side of the machine.



17. Make sure there is sufficient space to lower the walking deck.

**⚠ Keep a minimum clearance behind the machine of 79" (2 m) and 19.7" (0.5 m) on each side. This is the recommended safe distance for access, movement and emergency dismounts from the machine.**

18. Make sure there is no object on or around the treadmill to spill or cause blockage from the fully unfolded position.

19. Slightly push the walking deck forward toward the console. With your foot lightly push the top part of the hydraulic lift forward until the locking tube releases and you can pull the walking deck away from the console. Hold up the rear of the walking deck, and move to the side of the machine.

**⚠ Keep clear of the movement path of the walking deck.**

20. The hydraulic lift is set up to drop gradually. Hold onto the walking deck until approximately 2/3 of the movement down. Lower the weight with your legs. Be aware that the walking deck can possibly drop quickly in the last part of the movement.

21. Using a 6mm hex wrench, remove the 2 indicated screws from the right side of the Deck.

22. Repeat the previous Step on the Left side of the machine.

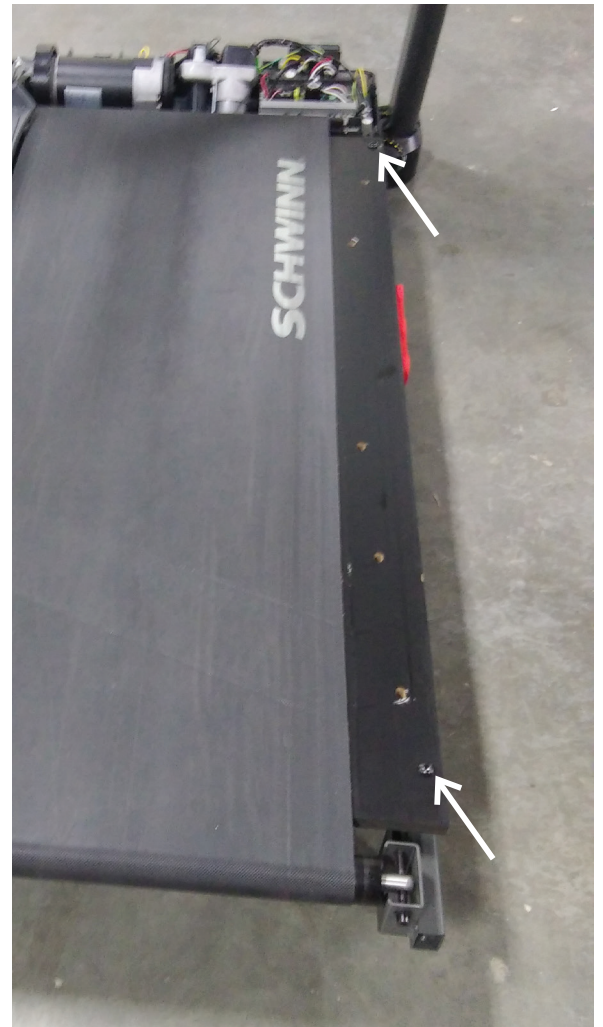



23. Slide the old Walking Deck Assembly out of the Walking Belt, and flip over so the Walking Belt Guides are exposed.

24. Using a #2 Phillips screwdriver, remove the Walking Belt Guides and attach them to the new Walking Deck in the same orientation.

25. Turn over the new Walking Deck Assembly, and replace it between the Walking Belt in the same orientation.

26. Using a 6mm hex wrench, re-install the 4 screws to the Deck.

27. Re-install all remaining parts that were removed in reverse order.

28. Inspect the surface material below the Treadmill. If the surface material is difficult to clean or could be damaged by silicone lubricant, place absorbent material (such as cardboard or newspaper) below the length of the Walking Deck.

29. Apply a few drops of the lubricant on the deck below the belt. Carefully lift the belt and apply a few drops of the lubricant the entire width of the belt. A very thin layer of silicone lubricant on the entire deck below the belt is desired.

**NOTICE:** Always use a 100% pure silicone lubricant. Do not use a degreaser like WD-40® as this could seriously impact performance. We can recommend that you use the following:

- 100% pure silicone, available at most hardware and auto parts stores.
- Lube-N-Walk® Treadmill Lubrication Kit, available from your local specialty fitness dealer or Nautilus, Inc.

**!** **Silicone lubricant is not intended for human consumption. Keep out of reach of children. Store in a safe place.**

30. Manually rotate the belt 1/2 of the length of the belt and apply lubricant again.

**!** **If you used spray lubricant, wait 5 minutes before turning on power to the machine to allow the aerosol to dissipate.**

31. Connect the power cord back into the machine and then into the wall outlet.

32. Turn on the power to the machine with the power switch.

33. Stay to one side of your machine and start the belt at the slowest speed. Let the belt operate for approximately 15 seconds.

**!** **Be sure not to touch the walking belt or step on the power cord. Keep bystanders and children away from the product you are servicing at all times.**

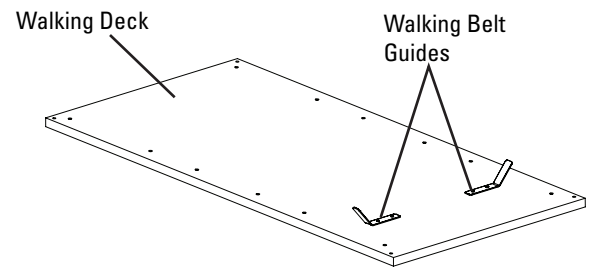



34. Switch off your machine.

35. Take care to clean up any excess lubricant from the deck.

 **To decrease the possibility of slipping, be sure the deck area is free from grease or oil. Clean off any excess oil from the machine surfaces.**

36. Final Inspection

Inspect your machine to ensure that all hardware is tight and components are properly assembled.

 **Do not use until the machine has been fully assembled and inspected for correct performance in accordance with the Owner's Manual.**