

# SCHWINN™

## 810 / 510T

### QUICK START MANUAL



If purchased in US/Canada:

## **! WARNING**

Do not operate this machine until you read and understand the complete Owner's Manual provided online here: <http://www.schwinnfitness.com/manuals>

In the event that you do not have a computer or on-line access and require a hard copy of the Manual, please contact Nautilus at (800) 605-3369 and we will provide one for you. In either case, before first use please read and understand the Owner's Manual.

If purchased outside US/Canada:

## **! WARNING**

Do not operate this machine until you read and understand the complete Owner's Manual provided online here: [www.nautilusinternational.com](http://www.nautilusinternational.com) or [www.nautilus.cn](http://www.nautilus.cn)

To validate warranty support, keep the original proof of purchase and record the following information:

Serial Number \_\_\_\_\_

Date of Purchase \_\_\_\_\_

**If purchased in US/Canada:** To register your product warranty, go to: [www.schwinnfitness.com/register](http://www.schwinnfitness.com/register) or call 1 (800) 605-3369.

**If purchased outside US/Canada:** To register your product warranty, contact your local distributor.

For details regarding product warranty or if you have questions or problems with your product, please contact your local distributor. To find your local distributor, go to: [www.nautilusinternational.com](http://www.nautilusinternational.com)

## **IMPORTANT SAFETY INSTRUCTIONS**

When using an electrical appliance, basic precautions should always be followed, including the following:

**! This icon means a potentially hazardous situation which, if not avoided, could result in death or serious injury.**

Obey the following warnings:

**! Read and understand all warnings on this machine.**

## **! DANGER**

Carefully read and understand the Assembly instructions. Read and understand the complete Manual. Keep the Manual for future reference.

## **! DANGER**

To reduce the risk of electrical shock or unsupervised usage of the equipment, always unplug this machine from the electrical outlet immediately after using and before cleaning.

## **! WARNING**

To decrease the risk of burns, electric shock, or injury to persons, read and understand the complete Owner's Manual. Failure to follow these guidelines can cause a serious or possibly fatal electrical shock or other serious injury.

- Keep bystanders and children away from the product you are assembling at all times.
- Do not connect power supply to the machine until instructed to do so.
- The machine should never be left unattended when plugged in. Unplug from outlet when not in use, and before putting on or taking off parts.
- Before each use, examine the machine for damage to power cord, loose parts or signs of wear. Do not use if found in this condition. If purchased in US/Canada, contact Customer Service for repair information. If purchased outside US/Canada, contact your local distributor for repair information.
- Not intended for use by persons with medical conditions where those conditions may impact the safe operation of the treadmill or pose a risk of injury to the user.

- Do not drop or put objects into any opening of the machine.
- Never operate this treadmill with the air openings blocked. Keep the air openings free of lint, hair and the like.
- Do not assemble this machine outdoors or in a wet or moist location.
- Make sure assembly is done in an appropriate work space away from foot traffic and exposure to bystanders.
- Some components of the machine can be heavy or awkward. Use a second person when doing the assembly steps involving these parts. Do not do steps that involve heavy lifting or awkward movements on your own.
- Set up this machine on a solid, level, horizontal surface.
- Do not try to change the design or functionality of this machine. This could compromise the safety of this machine and will void the warranty.
- If replacement parts are necessary, use only genuine Nautilus replacement parts and hardware. Failure to use genuine replacement parts can cause a risk to users, keep the machine from operating correctly and void the warranty.
- Do not use until the machine has been fully assembled and inspected for correct performance in accordance with the Manual.
- Use this machine only for its intended use as described in this manual. Do not use attachments not recommended by the manufacturer.
- Do all assembly steps in the sequence given. Incorrect assembly can lead to injury or incorrect function.
- Connect this machine to a properly grounded outlet only (see Grounding or Earthing Instructions).
- Keep the power cord away from heat sources and hot surfaces.
- Do not operate where aerosol products are being used.
- To disconnect, turn all controls to the off position, then remove plug from outlet.
- Silicone lubricant is not intended for human consumption. Keep out of reach of children. Store in a safe place.

## • SAVE THESE INSTRUCTIONS.

Before using this equipment, obey the following warnings:

-  **Read and understand the complete Manual. Keep the Manual for future reference.**
- Read and understand all warnings on this machine. If at any time the Warning labels become loose, unreadable or dislodged, replace the labels. If purchased in US/Canada, contact Customer Service for replacement labels. If purchased outside US/Canada, contact your local distributor for them.**

 **DANGER** To reduce the risk of electrical shock or unsupervised usage of the equipment, always unplug the power cord from the wall outlet and the machine and wait 5 minutes before cleaning, maintaining or repairing the machine. Place the power cord in a secure location.

- Children must not be let on or near to this machine. Moving parts and other features of the machine can be dangerous to children.
- Not intended for use by anyone under 14 years of age.
- Consult a physician before you start an exercise program. Stop exercising if you feel pain or tightness in your chest, become short of breath, or feel faint. Contact your doctor before you use the machine again. Use the values calculated or measured by the machine's computer for reference purposes only.
- Before each use, examine this machine for damage to power cord, power receptacle, loose parts or signs of wear. Do not use if found in this condition. If purchased in US/Canada, contact Customer Service for repair information. If purchased outside US/Canada, contact your local distributor for repair information.
- This appliance should only be used with the power supply unit provided, or a replacement power supply unit supplied from Nautilus, Inc.
- Maximum user weight limit: 125 kg (275 lbs.). Do not use if you are over this weight.
- This machine is for home use only. Do not place or use the machine in a commercial or institutional setting. This includes gyms, corporations, work places, clubs, fitness centers and any public or private entity that has a machine for use by its members, customers, employees or affiliates.
- Do not wear loose clothing or jewelry. This machine contains moving parts. Do not put fingers or other objects into moving parts of the exercise equipment.
- Always wear rubber soled athletic shoes when you use this machine. Do not use the machine with bare feet or only wearing socks.
- Set up and operate this machine on a solid, level, horizontal surface.
- Use caution when you step on and off the machine. Use the supplied foot support platforms for stability before walking on the moving belt.
- To prevent injury, stand on the Foot Platforms before you start the machine or end a workout. Do not dismount the machine by standing on the moving Walking Belts and exiting off the rear of the unit (or machine).
- Disconnect all power before servicing this machine.
- Do not operate this machine outdoors or in moist or wet locations.
- Keep at least 0.5 m (19.7") on each side of the machine and 2 m (79") behind the machine clear. This is the recommended safe distance for access and passage around and emergency dismounts from the machine. Keep third parties out of this space when machine is in use.

- Do not over exert yourself during exercise. Operate the machine in the manner described in this manual.
- Perform all regular and periodic maintenance procedures recommended in the Owner's Manual.
- Read, understand, and test the Emergency Stop Procedure before use
- Keep the walking belt clean and dry.
- Do not drop or put objects into any opening of the machine.
- Do not stand on machine motor cover or front trim cover.
- Keep power cord away from heat source and hot surfaces.
- This machine must be connected to an appropriate, dedicated electrical circuit. Nothing else must be connected to the circuit.
- Always connect the power cord to a circuit capable of handling 15 amperes for 110V AC or 10 amperes for 220-240V AC with no other loads applied.
- Connect this machine to a correctly grounded or earthed outlet; consult a licensed electrician for assistance.
- Do not operate where aerosol products are being used.
- Do not let liquids touch the electronic controller. If it does, the controller must be inspected and tested for safety by an approved technician before it can be used again.
- Do not remove the machine motor cover or the rear roller cover, dangerous voltages and moving parts are present. The components are serviceable only by approved service personnel or by following service procedures supplied by Nautilus, Inc.
- The electrical wiring for the residence in which the machine will be used must obey the applicable local and provincial requirements.
- Exercise on this machine requires coordination and balance. Be sure to anticipate that changes in belt speed and incline angle of deck can occur during workouts, and be attentive in order to avoid loss of balance and possible injury
- A machine should never be left unattended when plugged in. Unplug from outlet when not in use, and before putting on or taking off parts.
- Use this machine only for its intended use as described in this manual. Do not use attachments not recommended by the manufacturer.
- This appliance is not intended for use by persons with reduced physical, sensory or mental capabilities, or lack of knowledge, unless they have been given supervision or instruction concerning use of the appliance by a person responsible for their safety. Keep children under the age of 14 away from this machine.
- Children should be supervised to ensure that they do not play with the appliance.
- Use the values calculated or measured by the machine's computer for reference purposes only. The heart rate displayed is an approximation and should be used for reference only. Over exercising may result in serious injury or death. If you feel faint stop exercising immediately.
- **SAVE THESE INSTRUCTIONS.**

## FCC Compliance

 **Changes or modifications to this unit not expressly approved by the party responsible for compliance could void the user's authority to operate the equipment.**

The machine and power supply comply with part 15 of the FCC rules. Operation is subject to the following two conditions: (1) This device may not cause harmful interference, and (2) this device must accept any interference received, including interference that may cause undesired operation.

**Note:** This machine and power supply have been tested and found to comply with the limits for a Class B digital device, pursuant to Part 15 of the FCC Rules. These limits are designed to provide reasonable protection against harmful interference in a residential installation. This equipment generates, uses and can radiate radio frequency energy and, if not installed and used in accordance with the instructions, may cause harmful interference to radio communications.

However, there is no guarantee that interference will not occur in a particular installation. If this equipment does cause harmful interference to radio or television reception, which can be determined by turning the equipment off and on, the user is encouraged to try to correct the interference by one or more of the following measures:

- Reorient or relocate the receiving antenna.
- Increase the separation between the equipment and receiver.
- Connect the equipment into an outlet on a circuit different from that to which the receiver is connected.
- Consult the dealer or an experienced radio/TV technician for help.

## Grounding Instructions (for a 120V AC system )

This product must be grounded. If it should malfunction or break down, grounding provides a path of least resistance for electric current to reduce the risk of electric shock. This product is equipped with a cord having an equipment-grounding conductor and a grounding plug. The plug must be plugged into an appropriate outlet that is properly installed and grounded in accordance with all local codes and ordinances.

**⚠ DANGER**

**Improper connection of the equipment-grounding conductor can result in a risk of electric shock. Check with a qualified electrician or serviceman if you are in doubt as to whether the product is properly grounded. Do not modify the plug provided with the product – if it will not fit the outlet, have a proper outlet installed by a qualified electrician.**

If you connect the machine to an outlet with GFI (ground fault interrupt) or AFI (arc fault interrupt), machine operation can cause the circuit to trip. This machine is for use on a nominal 120-V circuit, and has a grounding plug that looks like the plug illustrated below. A temporary adapter that looks like the adapter illustrated may be used to connect this plug to a 2-pole receptacle as shown if a properly grounded outlet is not available.

The temporary adapter should be used only until a properly grounded outlet can be installed by a qualified electrician. The tab for the grounding screw must be connected to a permanent ground such as a properly grounded outlet box cover. Whenever the adapter is just be held in place by a metal screw.

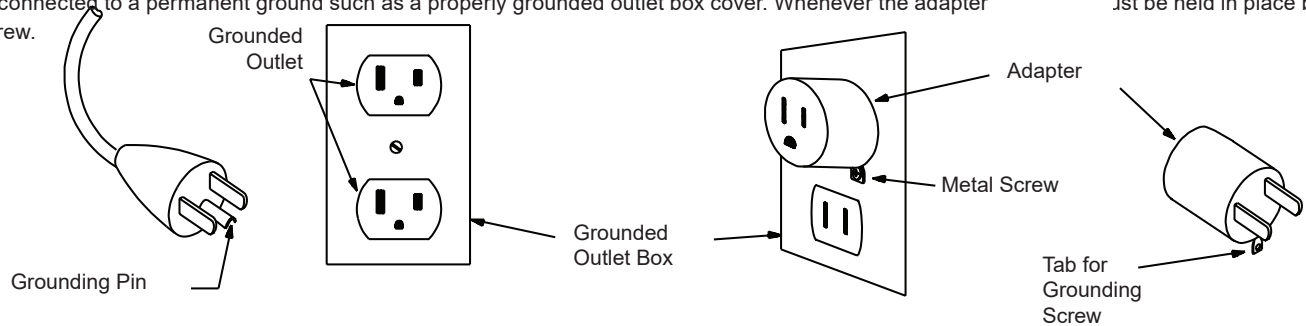

## Earthing Instructions (for a 220-240V AC system )

This product must be electrically earthed. If a malfunction occurs, correct earthing decreases the risk of electric shock. The power cord is equipped with an equipment-earthing conductor, and must be connected to an outlet that is properly installed and earthed.

**⚠ DANGER**

**The electrical wiring must comply with all applicable local and provincial standards and requirements. Incorrect connection of the equipment-earthing conductor can result in a risk of electric shock. Consult a licensed electrician if you are not sure that the machine is correctly earthed. Do not change the plug on the machine – if it does not fit the outlet, have a correct outlet installed by a licensed electrician.**

If you connect the machine to an outlet with RCBO (Residual-Current circuit Breaker with Overload protection), machine operation can cause the circuit to trip. A Surge Protector Device is recommended to protect the machine.

**⚠ If a Surge Protector Device (SPD) is used with this machine, be sure that it matches the power rating of this equipment (220-240V AC). Do not connect other appliances or devices to the surge protector in combination with this machine.**

**Make sure that the product is connected to an outlet having the same configuration as the plug. Use the appropriate adapter supplied with this product.**

## Emergency Stop Procedure

The Treadmill machine is equipped with a Safety Key that can prevent serious injury, as well as prevent children from playing with and/or being injured on the machine. If the Safety Key is not correctly inserted into the Safety Key Port, the belt will not operate.

**⚠ Always attach the Safety Key Clip to your clothing during your workout.**

**When you use the machine, only remove the Safety Key in an emergency. When the key is removed while the machine is in operation, it will stop quickly, which could cause the loss of balance and possible injury.**

**For safe storage of the machine, and to prevent unsupervised operation of the machine, always remove the Safety Key and disconnect the power cord from the wall outlet and the AC input. Place the power cord in a secure location.**

The Console will display " + SAFETY KEY ", or add Safety Key, for a Safety Key fault. The Treadmill machine will not start a Workout, or will end and clear an active Workout, when the Safety Key is removed. Inspect the Safety Key and be sure it is connected to the Console correctly.

<b>Power Requirements:</b>	<b>120V</b>	<b>220V</b>
Operational Voltage:	110-127V AC, 60Hz	220V - 240V AC, 50/60Hz
Operating Current:	15 A	8 A

<b>Maximum User Weight:</b>	125 kg (275 lbs)
<b>Total Surface Area (footprint) of equipment:</b>	15,848 cm <sup>2</sup>
<b>Maximum Inclined Deck Height:</b>	40 cm (15.8 inches)
<b>Machine Weight:</b>	70.3 kg (155 lbs)

**Sound Emission:** Less than 70 db average without load. Noise emission under load is higher than without load.



DO NOT dispose of this product as refuse. This product is to be recycled. For proper disposal of this product, please follow the prescribed methods at an approved waste center.

## WARNING!

Keep young children away from this machine at all times. Contact with the moving surface may result in severe friction burns.

(This label is only available on the 510T machine in English and Chinese.)

## WARNING!

**HAZARDOUS VOLTAGE.**

- Contact may cause electrical shock or burn.
- Turn off and lock out power before servicing.

## WARNING!

- Moving parts can crush and cut.
- Keep guards in place.
- Lock out power before servicing.

(These labels are in English and French Canadian on the 810 machine, and English, French Canadian and Chinese on the 510T machine.)

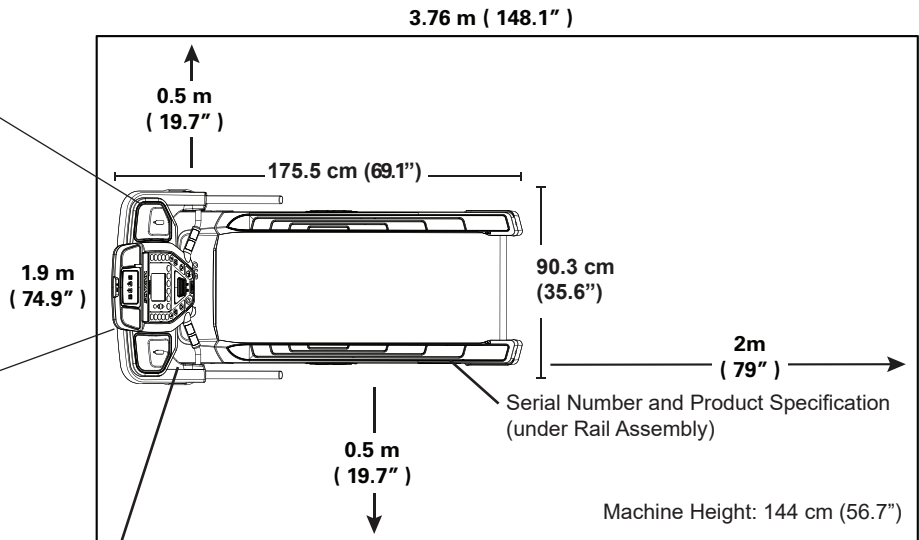

## CAUTION

Risk of Injury to Persons - To Avoid injury, use extreme caution when stepping onto or off of a moving belt. Read instruction manual before using.

## WARNING!

- Injury or death is possible if caution is not used while using this machine.
- Keep children and pets away.
- Read and follow all warnings on this machine.
- Refer to the Owner's Manual for additional warnings and safety information.
- The heart rate displayed is an approximation and should be used for reference only.
- Not intended for use by anyone under 14 years of age.
- The maximum user weight for this machine is 275 lbs (125 kg).
- For Consumer Use Only.
- Consult a physician prior to using any exercise equipment.
- REMOVE SAFETY KEY WHEN NOT IN USE, AND STORE OUT OF REACH OF CHILDREN.

(This label is only available on the 810 machine in English and French Canadian.)

Folded Dimensions:

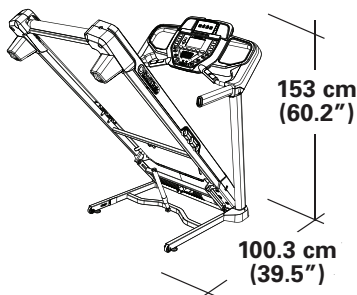

## Before Assembly

Select the area where you are going to set up and operate your machine. For safe operation, the location must be on a hard, level surface. Allow a minimum workout area of 190.3 cm x 376.2 cm (74.9" x 148.1"). Be sure that the workout space you are utilizing has adequate height clearance, taking into consideration the height of the user and the maximum incline of the machine.

## Machine Mat

The Schwinn™ Machine Mat is an optional accessory that helps keep your workout area clear and adds a layer of protection to your floor. The rubber machine mat provides a non-slip, rubber surface which limits static discharge and reduces the possibility of display errors. If possible, put your Schwinn™ Machine Mat in your selected workout area before you begin assembly.

To order the optional machine mat, contact Customer Service (if purchased in US/Canada) or your local distributor (if purchased outside US/Canada).

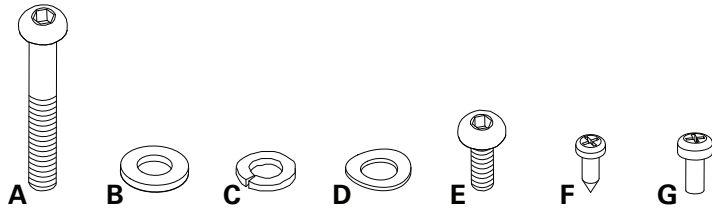

Item	Qty	Description	Item	Qty	Description
A	8	Button Head Hex Screw, M8x1.25x85	E	4	Button Head Hex Screw, M8x1.25x16
B	10	Flat Washer, M8	F	2	Self Tapping Screw, M3.9x13
C	12	Lock Washer, M8	G	6	Phillips Head Screw, M4x0.7x12
D	2	Curved Washers, M8			

**Note:** Select pieces of Hardware have been provided as spares on the Hardware Card. Be aware that there may be remaining Hardware after the proper assembly of your machine.

## Tools

Included



#2  
6 mm



6 mm

## ⚠ WARNING

DO NOT CUT the Shipping Strap on the Base Assembly until it has been placed face up as shown in the appropriate work space (\*).

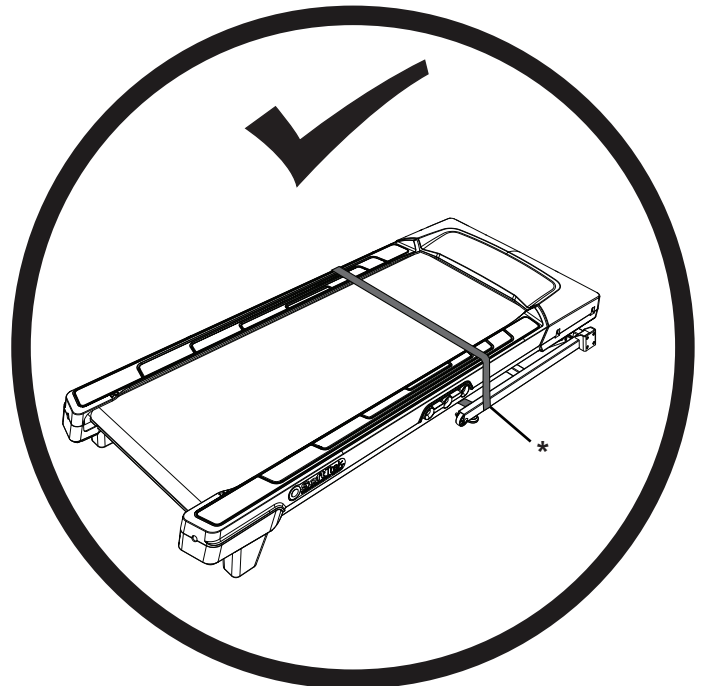
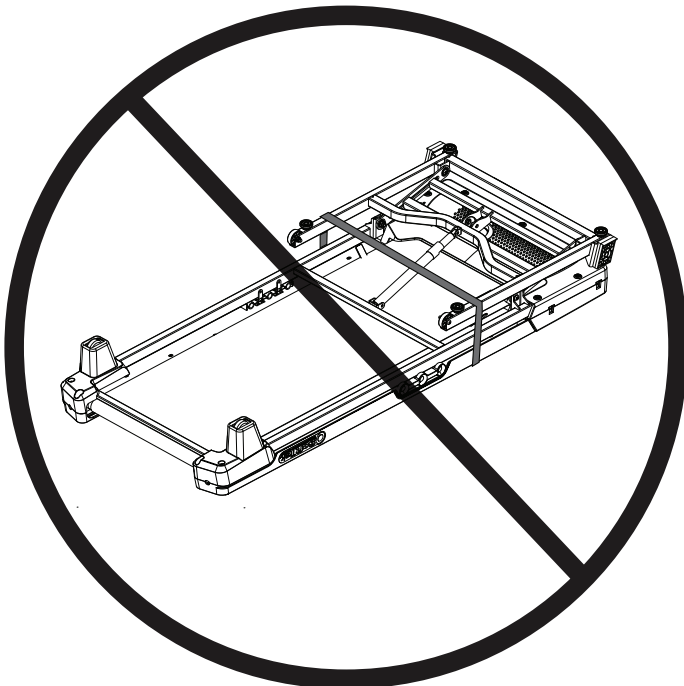

## Step 1.

Cut the Shipping Strap on the Base Assembly. Make sure that there is safe clearance around, on and above your treadmill. Make sure there is no object to spill or cause blockage from the fully folded position. Be sure there is adequate height clearance for the raised deck. Using the support bar found below the rear of the walking belt, lift the walking deck fully upward and engage the hydraulic lift. Be sure that the hydraulic lift is correctly locked in place. You will hear an audible click when the hydraulic lift shifts into the locked position.

**!** Use proper safety precautions and lifting techniques. Bend your knees and elbows, keep your back straight and pull up equally with both arms. Make sure that your own physical strength is capable of lifting the walking deck until it engages the locking mechanism. Use a second person if necessary.

**Do not use the walking belt or rear roller to lift the treadmill. These parts do not lock in place and can abruptly move. Injury to you or damage to the machine can occur.**

Make sure that the locking mechanism is engaged. Carefully pull back on the Walking Deck and make sure that it does not move. When you do this, keep clear of movement path in case the treadmill lock is not engaged.

**!** Do not lean against the treadmill when it is folded. Do not put items on it that could cause it to become unstable or fall.

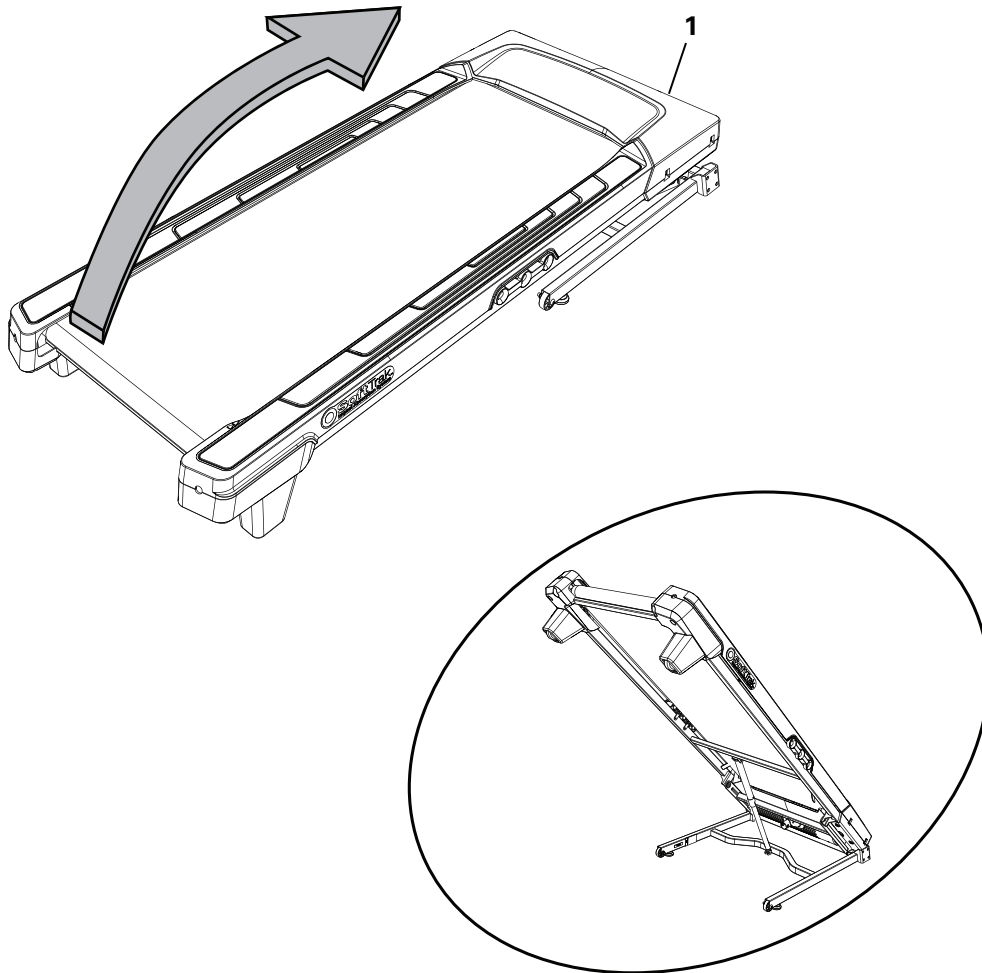

Item	Qty	Description
1	1	Base Assembly



## Step 2.

**Note:** Do not crimp the Cables. Do not fully tighten Hardware until instructed. Slightly push the walking deck forward toward the front of the machine. With your left foot lightly push the top part of the hydraulic lift forward until the locking tube releases and you can pull the walking deck slightly toward the rear of the machine. Hold up the rear of the walking deck, and move to the side of the machine.

**!** Keep clear of the movement path of the walking deck.

The hydraulic lift is set up to drop lightly. Hold onto the walking deck until approximately 2/3 of the movement down. Make sure that you use proper lifting technique; bend your knees and keep your back straight. The walking deck can possibly drop quickly in the last part of the movement.

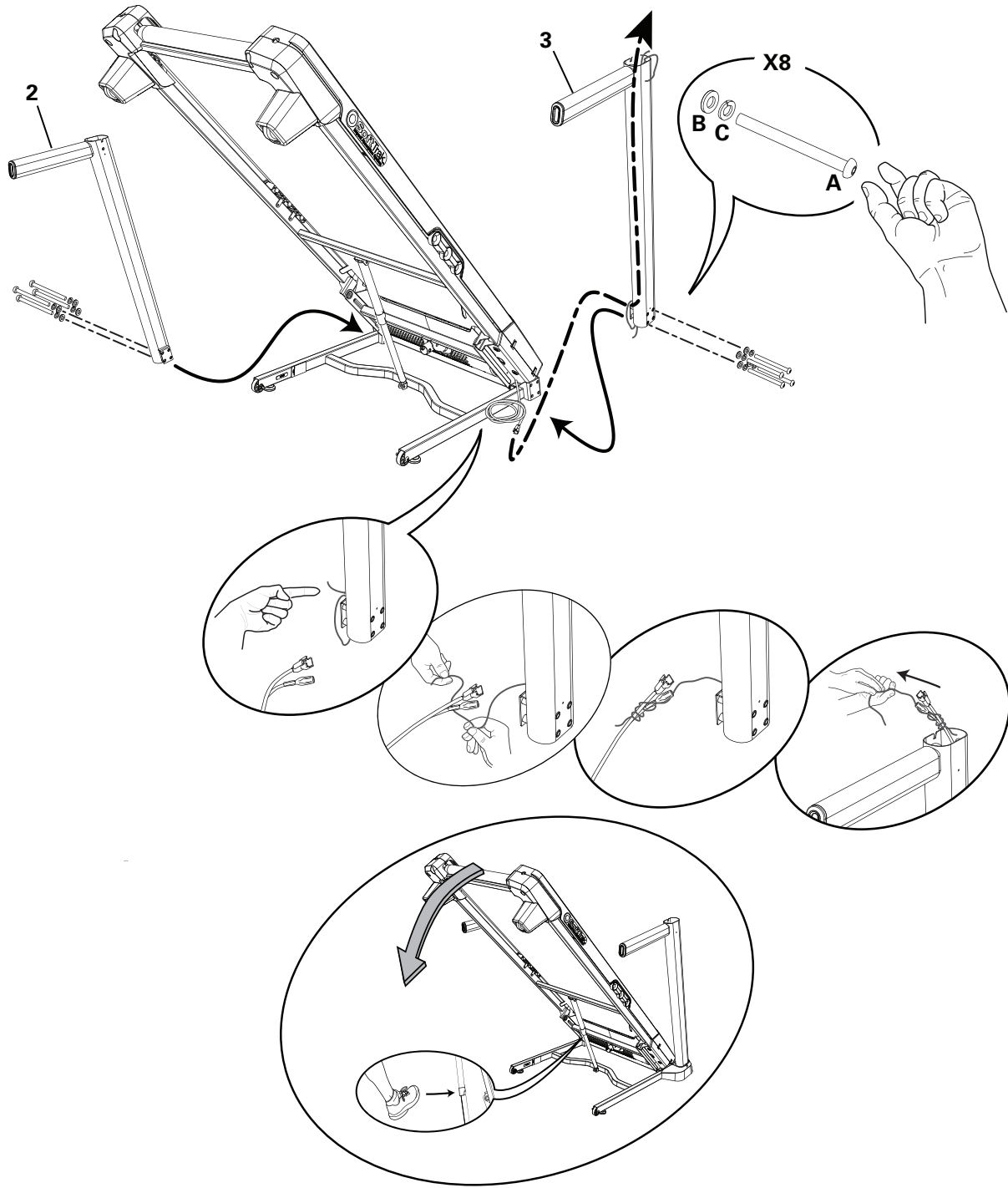

Item	Qty	Description	Item	Qty	Description
2	1	Upright, Left	3	1	Upright, Right



### Step 3.

**Note:** Do not crimp the Cables. Be sure the hooks on the Console are set into the notches of the Uprights. \*Install the front hardware first. Tray edges should be flush with the face of Console.

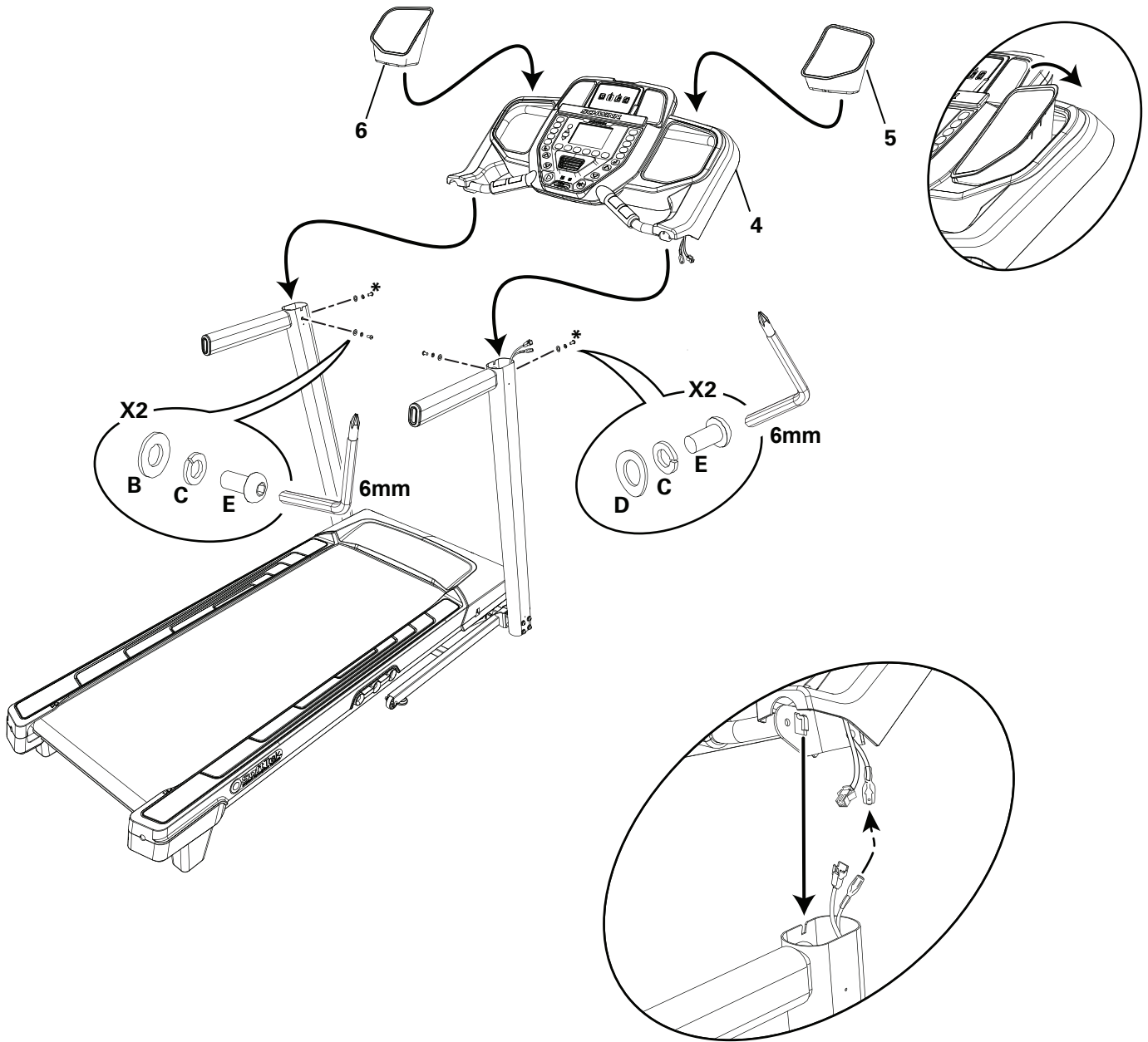

Item	Qty	Description	Item	Qty	Description	Item	Qty	Description
4	1	Console Assembly	5	1	Tray, Right	6	1	Tray, Left

## Step 4. Fully tighten all Hardware from previous Steps



## Step 5.

**NOTICE:** \*Install the Inner Handlebar Shrouds first. The parts are marked to assist with assembly.



Connect this machine to a properly grounded outlet only (see Grounding or Earthing Instructions).

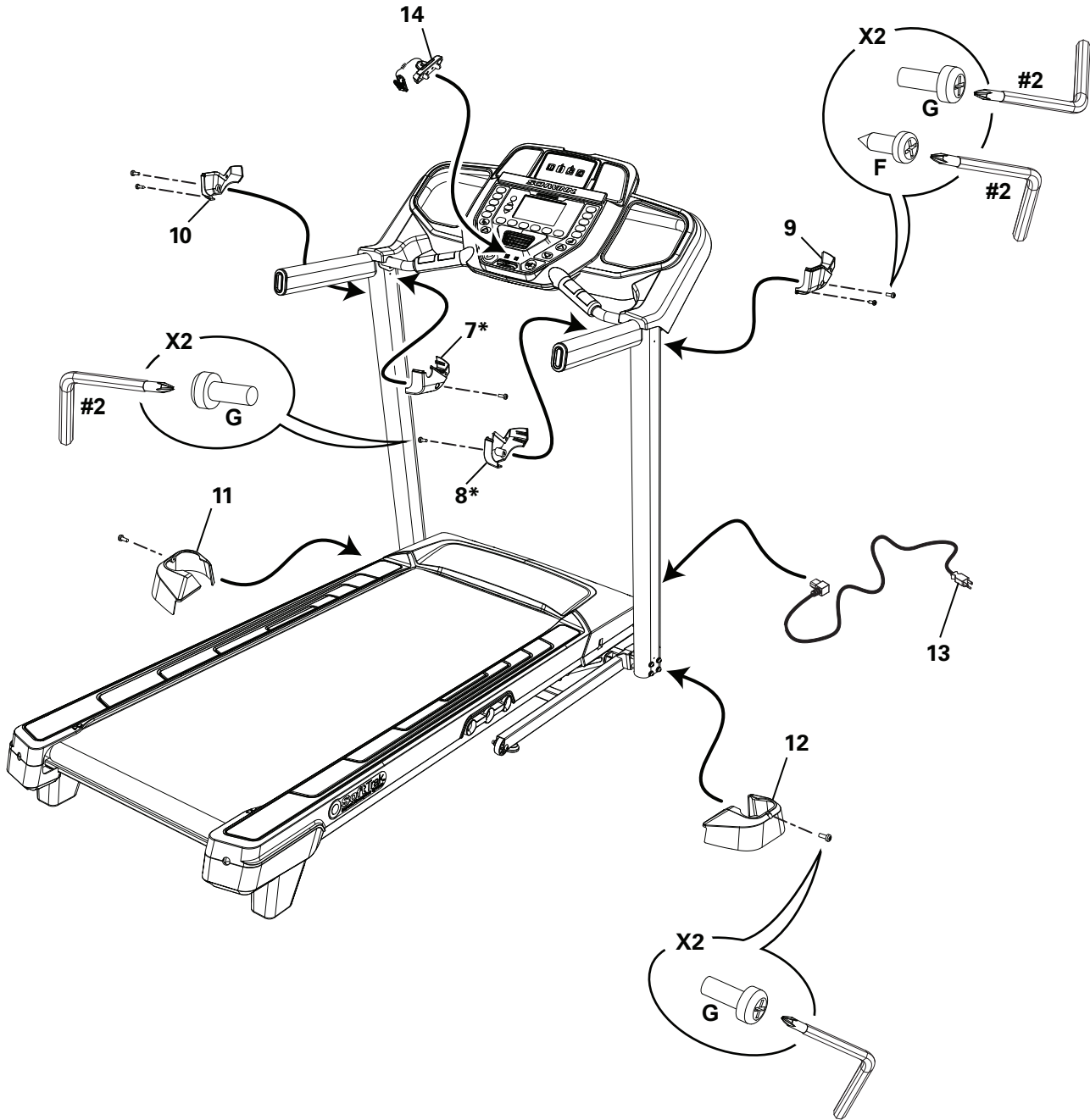

Item	Qty	Description	Item	Qty	Description	Item	Qty	Description
7	1	Handlebar Shroud, Left Inner (L-R)	10	1	Handlebar Shroud, Left Outer (L-L)	13	1	Power Cord
8	1	Handlebar Shroud, Right Inner (R-L)	11	1	Base Shroud, Left	14	1	Safety Key
9	1	Handlebar Shroud, Right Outer (R-R)	12	1	Base Shroud, Right			

## Step 6.

### Final Inspection

Inspect your machine to ensure that all hardware is tight and components are properly assembled.

Be sure to record the serial number in the field provided at the front of this manual.

**!** Do not use until the machine has been fully assembled and inspected for correct performance in accordance with the Owner's Manual.

## ADJUSTMENTS / OPERATION

### Moving and Storing the Machine

**!** The machine can be moved by one or more persons. Use caution when you move the machine. The treadmill is heavy and can be awkward. Make sure that your own physical strength is capable of moving the machine. Use a second person if necessary.

1. Before the machine can be moved, inspect the Walking Deck to be sure the Incline setting is at "1". If necessary, adjust the Incline setting to "1".

**!** Be sure the area below the machine is clear before adjusting the incline of the Deck. Fully lower the incline of the Deck after each workout.

2. Remove the Safety Key and place it in a secure location.

**!** When this machine is not in operation, remove the Safety Key and keep out of the reach of children.

3. Make sure that the power switch is turned Off, and the power cord is disconnected.

4. You must fold the treadmill before you move it. Never move the treadmill if it is not folded.

**!** Never move the machine with the Walking Deck not folded. Rotating or moving parts can pinch, resulting in personal injury.

5. Make sure that there is safe clearance around, on and above your treadmill. Be sure to remove all water bottles, media devices, or loose items from the machine before moving it.

**!** Be sure there is adequate height clearance for the raised deck.

6. Using the support bar found below the rear of the walking belt, lift the walking deck fully upward and engage the hydraulic lift. Be sure that the hydraulic lift is correctly locked in place. You will hear an audible click when the hydraulic lift shifts into the locked position.

**!** Use proper safety precautions and lifting techniques. Bend your knees and elbows, keep your back straight and pull up equally with both arms. Straighten your legs to lift. Make sure that your own physical strength is capable of lifting the walking deck until it engages the locking mechanism. Use a second person if necessary.

Do not use the walking belt or rear roller to lift the treadmill. These parts do not lock in place and can abruptly move. Injury to you or damage to the machine can occur.

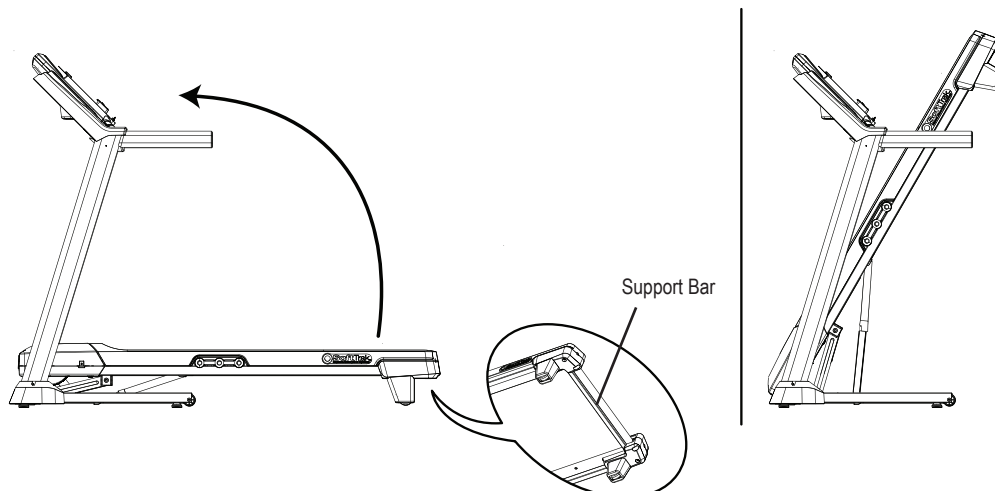

7. Make sure that the locking mechanism is engaged. Carefully pull back on the Walking Deck and make sure that it does not move. When you do this, keep clear of movement path in case the treadmill lock is not engaged.



**Do not lean against the treadmill when it is folded. Do not put items on it that could cause it to become unstable or fall.**

**Do not connect the power cord or try to operate the treadmill in the folded position.**

8. Stand to one side of the treadmill. Place your front foot so it pins the Base Assembly. Grasping the Side Handrail, carefully pivot the treadmill rearward until it is balanced fully on the transport wheels. Be sure not to pivot the machine too far. Hold the treadmill in the balanced position.



**This step may require two persons on each side of the treadmill. The treadmill is heavy and can be awkward. Make sure that your own physical strength is capable of pivoting the machine.**

**Always wear fully enclosed shoes when moving this machine. Do not move the machine with bare feet or only wearing socks.**

**Do not use the Console or lifted Walking Deck to pivot or move the treadmill. Injury to you or damage to the machine can occur.**

**Keep clear of the movement path of the lifted Walking Deck.**

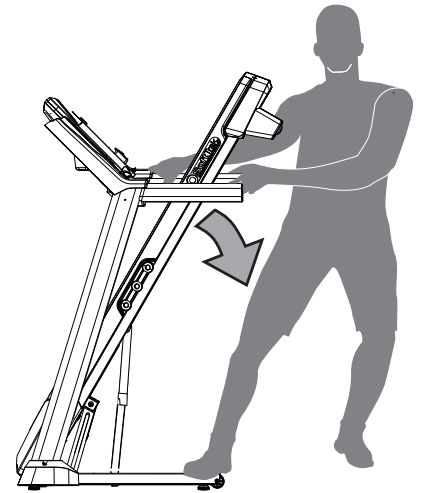

9. Grasping the Side Handrail and the front of the Upright, safely roll the treadmill to the desired location.



**The treadmill is heavy and can be awkward. Make sure that your own physical strength is capable of moving the machine.**

**Place the machine on a clean, hard, level surface, free from unwanted material or other objects that may hamper your ability to move freely. A rubber mat should be used below the machine to prevent the release of static electricity and protect your flooring.**

**Do not put objects in the path of the walking deck when lowered.**

NOTICE: Move the machine carefully so that it does not hit other objects. This can damage the Console operation, the treadmill, or the area around the machine.

10. Safely lower the treadmill into the desired position. Be sure there is adequate space for the machine before lowering it.

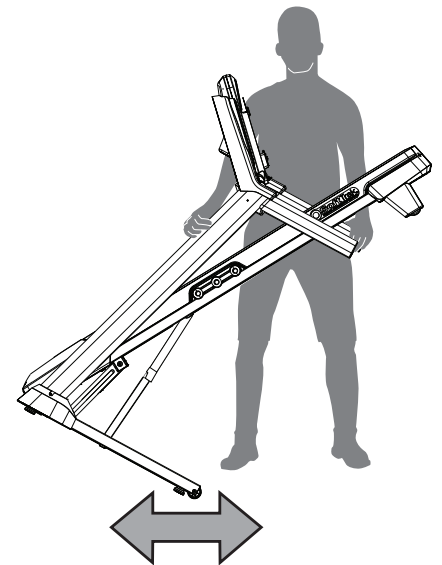

11. Prior to use, refer to the "Unfolding the Machine" procedure in this manual.

## Unfolding the Machine

1. Make sure there is sufficient space to lower the walking deck.



**Keep a minimum clearance behind the machine of 79" (2 m) and 24" (0.6 m) on each side. This is the recommended safe distance for access, movement and emergency dismounts from the machine.**

**Place the machine on a clean, hard, level surface, free from unwanted material or other objects that may hamper your ability to move freely with a sufficient clear workout area. A rubber mat below the machine is recommended to prevent electrostatic discharge and protect your floor.**

**Be sure that the workout space you are utilizing has adequate height clearance, taking into consideration the height of the user and the maximum incline of the deck.**

2. Make sure there is no object on or around the treadmill to spill or cause blockage from the fully unfolded position.

3. Slightly push the walking deck forward toward the console. With your left foot lightly push the top part of the hydraulic lift forward until the locking tube releases and you can pull the walking deck away from the console. Hold up the rear of the walking deck, and move to the side of the machine.

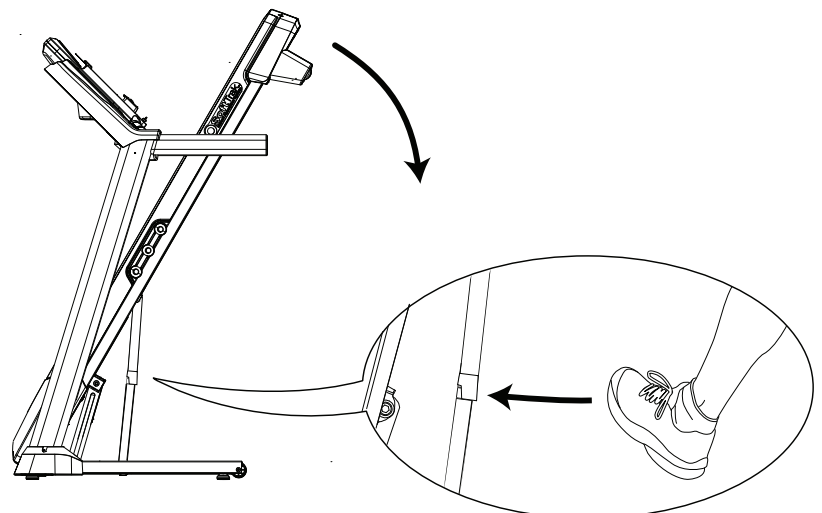

**!** Keep clear of the movement path of the walking deck.

4. The hydraulic lift is set up to drop lightly. Hold onto the walking deck until approximately 2/3 of the movement down. Make sure that you use proper lifting technique; bend your knees and keep your back straight. The walking deck can possibly drop quickly in the last part of the movement.

### Leveling the Machine

The machine needs to be leveled if your workout area is uneven. To adjust:

1. Place the machine in your workout area.
2. Adjust the levelers until they all contact the floor.

**!** Do not adjust the levelers to such a height that they detach or unscrew from the machine. Injury to you or damage to the machine can occur.

3. Adjust until the machine is level.

Make sure the machine is level and stable before you exercise.

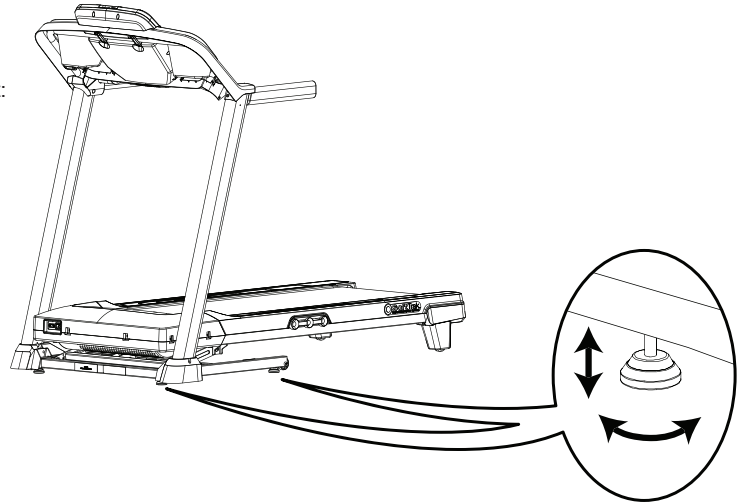

### Treadmill Belt

Your treadmill comes equipped with a durable, high quality walking belt designed to provide many hours of reliable service. The walking belt on a treadmill that has not been operated for a length of time, either in factory packaging or after assembly, can exhibit a “thumping” noise when started. This is due to the belt taking on the curve of the front and rear rollers. This is a common occurrence and does not indicate a problem with your machine. After the treadmill has been used for a short period of time the thumping noise will discontinue. The amount of time will vary depending on the temperature and humidity of the environment where the treadmill is placed.

## Workout with Other Fitness Apps

This fitness machine has integrated Bluetooth® connectivity which allows it to work with a number of digital partners. For our latest list of supported partners, please visit: [www.nutilus.com/partners](http://www.nutilus.com/partners)

## USB Charging

Your machine is equipped with a USB Port to allow it to charge some devices. Simply attach a USB Cable (not included) to the USB Port, and attach your device to the other end of the USB Cable. The power supplied from the USB Port may not be enough to operate the Device and charge it at the same time.

**Note:** The USB Port is only for charging and unable to play audio from the speakers on the Console.

## Remote Heart Rate Monitor

Monitoring your Heart Rate is one of the best procedures to control the intensity of your exercise. Contact Heart Rate (CHR) sensors are installed to send your heart rate signals to the Console. The Console can also read telemetry heart rate (HR) signals from a Heart Rate Chest Strap Transmitter that operates in the 4.5kHz - 5.5kHz range.

**Note:** The heart rate chest strap must be an uncoded heart rate strap from Polar Electro or an uncoded POLAR® compatible model. (Coded POLAR® heart rate straps such as POLAR® OwnCode® chest straps will not work with this equipment.)



**If you have a pacemaker or other implanted electronic device, consult your doctor before using a wireless chest strap or other telemetric heart rate monitor.**

## What to Wear

Wear rubber-soled athletic shoes. You will need the appropriate clothes for exercise that allow you to move freely.

## How Often Should You Exercise



**Consult a physician before you start an exercise program. Stop exercising if you feel pain or tightness in your chest, become short of breath, or feel faint. Contact your doctor before you use the machine again. Use the values calculated or measured by the machine's computer for reference purposes only. The heart rate displayed on the console is an approximation and should be used for reference only.**

- 3 times a week for 30 minutes each day.
- Schedule workouts in advance and try to follow the schedule.
- Consider doing some warm-up stretches, which will help prepare your body, before your workouts.

## Getting Started



**Consult a physician before you start an exercise program. Stop exercising if you feel pain or tightness in your chest, become short of breath, or feel faint. Contact your doctor before you use the machine again. Use the values calculated or measured by the machine's computer for reference purposes only.**

**Place the machine on a clean, hard, level surface, free from unwanted material or other objects that may hamper your ability to move freely with a sufficient clear workout area. A rubber mat below the machine is recommended to prevent electrostatic discharge and protect your floor.**

**Be sure that the workout space you are utilizing has adequate height clearance, taking into consideration the height of the user and the maximum incline of the deck.**

1. With the fitness machine in your workout area, inspect the walking belt to make sure it is centered and aligned. If necessary, refer to the "Aligning the Walking Belt" Procedure in the Maintenance section of this manual.



**The edges of the Walking Belt should be under the Side Foot Support Rails. If an edge of the Walking Belt can be viewed do not operate the machine. Adjust the Walking Belt until the edges are not viewable and are below the Side Foot Support Rails. Refer to the Aligning the Walking Belt Procedure.**

**Note:** This machine is for home use only.

2. Examine below the walking belt for any objects. Be sure it is clear below the machine.
3. Connect the Power Cord to a correctly grounded/earthed AC wall outlet.



**Do not step on the power cord and plug.**

**Note:** The machine is designed to plug directly into a properly wired and grounded/earthed outlet.

4. If you use the Wireless Heart Rate Chest Strap, follow the provided directions.
5. Switch on the power. Power is now supplied to the machine.

6. Straddle the walking belt and stand on the Side Foot Support Platforms. Put the Safety Key into the Safety Key Port and clip the Safety Key cord to your clothing.



**Care should be used when mounting or dismounting the machine.**

**To prevent injury, stand on the Foot Platforms before you start the machine or end a workout. Do not dismount the machine by standing on the moving Walking Belts and exiting off the rear of the unit (or machine).**

- Examine the Safety Key and be sure it is connected to the Console correctly.

**Note:** If the Safety Key is not installed, the machine will allow the User to perform all activities except to activate the Walking Belts. The Console will display the reminder to insert the Safety Key ( "SAFETY KEY" ).

- Always attach the Safety Key Clip to your clothing during workouts.

- If there is an emergency, pull out the Safety Key to shut off the power to the Belt and Incline Motors. This will quickly stop the belt (brace yourself- this is an abrupt stop) and clear the workout. Push the PAUSE/STOP button to stop the belt and pause the program.

7. Push the USER button to select the desired User for the workout.
8. Push the Workout Category button until your workout is displayed.
9. Push the OK button to select the workout.
10. The Console will ask a series of questions to customize the workout. Use the Increase(▲) or Decrease(▼) buttons to adjust the workout values, and push the OK button to accept each of them.
11. With your desired workout shown on the Console, push the START button.
12. When the Console displays the "READY ?" prompt, push the START button. The Console will display "RAMPING UP" as the Walking Belt gets up to speed. Be sure to carefully step onto the walking belt.



**The belt will only move after a 3 second, audible beep countdown.**

**Always use the handlebars to step on or off the treadmill, or when the incline or speed change.**

**To perform an emergency dismount, grab onto the Front or Side Handlebars and safely step onto the Side Foot Platforms. Bring the Walking Belt to a stop and carefully step off the machine.**

**Note:** Your treadmill comes equipped with a durable, high quality walking belt designed to provide many hours of reliable service. The walking belt on a treadmill that has not been operated for a length of time, either in factory packaging or after assembly, can exhibit a "thumping" noise when started. This is due to the belt taking on the curve of the front and rear rollers. This is a common occurrence and does not indicate a problem with your machine. After the treadmill has been used for a short period of time the thumping noise will discontinue. The amount of time will vary depending on the temperature and humidity of the environment where the treadmill is placed.

## Power-Up / Idle Mode

The Console will enter Power-Up / Idle Mode if it is plugged into a power source, the Power Switch turned on, and the Safety Key is properly installed.

**Note:** If the Safety Key is not installed, the machine will allow the User to perform all activities except to activate the Walking Belt. The Console will display the reminder to insert the Safety Key ( "SAFETY KEY" ). Once the Safety key is installed, the START button will need to be pushed again to begin the selected Workout.

## Auto Shut-Off (Sleep Mode)

If the Console does not receive any input in approximately 5 minutes, it will automatically shut off. The LCD display is off while in Sleep Mode.



**To disconnect, turn all controls to the off position, then remove plug from outlet.**



## Quick Start ( Manual ) Program

The Quick Start ( Manual ) program lets you start a workout without entering any information.

During a Manual Workout, each column represents a 1 minute and 52 seconds time period. The active column will advance across the screen every 1 minute and 52 seconds. If the workout lasts for more than 30 minutes, the active column is fixed on the farthest column on the right and pushes the previous columns off the display.

1. Stand on the Side Foot Support Platforms.
2. Push the User button to select the correct User profile. If you do not have a User profile set up, you can select a User profile that has no customized data (default values only).
3. Push the Manual Category button.
4. Push the START button to begin the Manual program.

**Note:** The Safety Key must be installed for a workout to begin. If not installed, the Console will display , "INSERT SAFETY KEY ". The Console will display "RAMPING UP" as the Walking Belt gets up to speed.

5. To change the Incline or Speed level, push the appropriate Increase or Decrease buttons. The time will count up from 00:00.

**Note:** The maximum time for a Quick Start workout is 9 hours, 59 minutes and 59 seconds (9:59:59).

6. When done with your workout, push PAUSE/STOP to pause the workout. Push PAUSE/STOP again to end the workout.

**Note:** The workout results are recorded to the current User Profile.

## Changing Incline Levels

Push the Incline Level Increase(▲) or Decrease(▼) buttons to change the incline angle of the Deck at any time with the Safety Key installed. To rapidly change the incline level push the desired Pre-Set Incline Button, and then the Incline Enter Button. The Deck will adjust to the selected incline level.

**Note:** After a Pre-Set Incline Button is pushed, the Incline Enter Button must be pushed within 5 seconds.

**!** Be sure the area below the machine is clear before lowering the Deck. Fully lower the Deck after each workout.

**Exercise on this machine requires coordination and balance. Be sure to anticipate that changes in belt speed and incline angle of deck can occur during workouts, and be attentive in order to avoid loss of balance and possible injury.**

Be sure that the workout space you are utilizing has adequate height clearance, taking into consideration the height of the user and the maximum height of the fully inclined Deck.

## Changing Speed Levels

Push the Speed Level Increase(▲) or Decrease(▼) buttons to change the Belt Speed at any time in a workout program. To rapidly change the Speed level push the desired Pre-Set Speed Button, and then the Speed Enter Button. The Walking Belt will adjust to the desired speed.

**Note:** After a Pre-Set Speed Button is pushed, the Speed Enter Button must be pushed within 5 seconds.

## Profile Programs

These programs feature different incline angles of the deck and belt speeds based on the maximum and minimum speed supplied by the user. The user can also manually adjust the incline and speed values at any time during a workout. The Profile Programs are organized into Category buttons (Manual, Goals, Weight Loss, Intervals, Heart Rate, and Custom). Each Profile Program has 16 segments allowing for a variety of workouts.

**!** During a Profile Program workout, the Console will make an audible beep when the next segment of the workout occurs. Be prepared for changes in incline and Speed with each segment change.

Select a type of workout by pushing the appropriate Workout Category button. The Console will display the first Profile Program Workout within that Category. Push the Workout Category button to select the desired Profile Program Workout from the Category of Workouts.

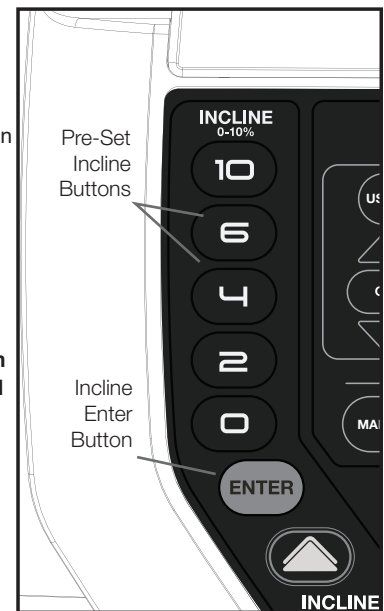

## MANUAL Workout Program

1. Push the MANUAL Category button.
2. Push the OK button.
3. The Console will display the "READY ?" prompt.
4. Push START to begin the goal-oriented workout.

## GOALS Workout Programs

1. Push the GOALS Category button.
2. Push the GOALS Category button to select the desired Profile Program Workout : TIME, CALORIE, DISTANCE, 1 MILE/1K, 5 MILES/5K, 10 MILE/10K.
3. Push the OK button.
4. Push the User Option Increase(▲) or Decrease(▼) buttons to adjust the Maximum Speed of the Belt, and push the OK button. The Profile Program will adjust so the Maximum Speed value is the highest Speed of the Profile Program when accepted.



**During a Workout, the User can directly adjust the speed of the belt above the Maximum Speed setting if desired.**

5. Use the User Option Increase(▲) or Decrease(▼) buttons to adjust the workout goal value, and push the OK button.
6. The Console will display the "READY ?" prompt.
7. Push START to begin the goal-oriented workout.

## WEIGHT LOSS Workout Programs

1. Push the WEIGHT LOSS Category button.
2. Push the WEIGHT LOSS Category button to select the desired Profile Program Workout : FAT BURN 1, SPEED BURN, INCLINE BURN.
3. Push the OK button.
4. Push the User Option Increase(▲) or Decrease(▼) buttons to adjust the Minimum Speed of the Belt, and push the OK button. The Profile Program will adjust so the Minimum Speed value is the lowest Speed of the Profile Program when accepted.
5. Push the User Option Increase(▲) or Decrease(▼) buttons to adjust the Maximum Speed of the Belt, and push the OK button. The Profile Program will adjust so the Maximum Speed value is the highest Speed of the Profile Program when accepted.



**During a Workout, the User can directly adjust the speed of the belt above the Maximum Speed setting if desired.**

6. Use the User Option Increase(▲) or Decrease(▼) buttons to select a type of Goal (Distance, Time or Calories), and push the OK button.
7. Use the User Option Increase(▲) or Decrease(▼) buttons to adjust the workout value, and push the OK button.
8. The Console will display the "READY ?" prompt.
9. Push START to begin the goal-oriented workout.

## INTERVALS Workout Programs

1. Push the INTERVALS Category button.
2. Push the INTERVALS Category button to select the desired Profile Program Workout : INTERVAL--INC, INTERVAL--SPD, INTERVAL--DUAL.
3. Push the OK button.
4. Push the User Option Increase(▲) or Decrease(▼) buttons to adjust the Minimum Speed of the Belt, and push the OK button. The Profile Program will adjust so the Minimum Speed value is the lowest Speed of the Profile Program when accepted.  
**Note:** The INTERVAL--INC Profile Program Workout does not have a Minimum Speed for the Belt option.
5. Push the User Option Increase(▲) or Decrease(▼) buttons to adjust the Maximum Speed of the Belt, and push the OK button. The Profile Program will adjust so the Maximum Speed value is the highest Speed of the Profile Program when accepted.



**During a Workout, the User can directly adjust the speed of the belt above the Maximum Speed setting if desired.**

6. Use the User Option Increase(▲) or Decrease(▼) buttons to adjust the Time Goal, and push the OK button.
7. The Console will display the "READY ?" prompt.
8. Push START to begin the goal-oriented workout.

## HEART RATE Workout Programs

The Heart Rate programs let you set a heart rate goal for your workout. The program monitors your heart rate in beats per minute (BPM) from the Contact Heart Rate (CHR) sensors on the machine or from a Heart Rate Monitor (HRM) strap, and adjusts the speed and/or incline during a workout to keep your heart rate in the selected zone.

**Note:** The console must be able to read the heart rate information from the Contact Heart Rate sensors or Heart Rate Monitor for the Heart Rate Control program to work correctly.

The Target Heart Rate programs use your age and other User information to set the Heart Rate Zone values for your workout. The console display then gives prompts for you to set up your workout:

1. Push the HEART RATE Category button.
2. Push the HEART RATE Category button to select the percentage of maximum heart rate: FAT BURN 65% or AEROBIC 75%.

 **Consult a physician before you start an exercise program. Stop exercising if you feel pain or tightness in your chest, become short of breath, or feel faint. Contact your doctor before you use the machine again. Use the values calculated or measured by the machine's computer for reference purposes only. The heart rate displayed on the console is an approximation and should be used for reference only.**

3. Push the User Option Increase(▲) or Decrease(▼) buttons to set the Minimum Speed, and push the OK button.
4. Push the User Option Increase(▲) or Decrease(▼) buttons to set the Maximum Speed, and push the OK button.
5. Push the User Option Increase(▲) or Decrease(▼) buttons to select the Goal type, and push the OK button.
6. Push the User Option Increase(▲) or Decrease(▼) buttons to set the goal value for the workout, and push the OK button.

**Note:** Be sure to allow time for your heart rate to reach the desired heart rate zone when setting the goal. The Console will display the heart rate value based on the current User settings.

7. Push START to begin the workout.

## CUSTOM Workout Program

The Custom workout program allows a user to “design as you go”, adjusting the currently active incline segment of each column. When the workout ends, the workout will be assigned to the Custom program.

In addition to the “design as you go” option, a completed workout that was slightly modified can be saved as the Custom program. At the end of the workout, the Console will ask if you would like to “SAVE WORKOUT” as the Custom workout. Push the OK button, and the workout is saved and assigned to the Custom program. All modifications to the workout segments are saved, allowing the same workout to be repeated by selecting the Custom program.

## Pausing or Stopping

The Console will go into Pause Mode if the user pushes PAUSE/STOP during a workout.

1. Push the PAUSE/STOP button to pause your workout. The Console will display “PAUSED”.
2. To continue your workout, push the START button.

To stop the workout, push the PAUSE/STOP button.

When a workout is ended or completed, the Console will display “SAVE WORKOUT?”. Push the OK button to save the workout as your Custom Program, or push the PAUSE/STOP button to not save the workout. The Console will show “COMPLETED” and begin the Results / Cool Down mode.

## Results / Cool Down Mode

All workouts except Quick Start and the Heart Rate Control programs have a 3 minute Cool Down period. During this Cool Down period, the Console shows the Workout Results. The Console will cycle through the workout results every 2 seconds while counting down the remaining time of the Cool Down period.

**Note:** The Cool Down values are not added to Workout Result values.

During the Cool Down period, the incline setting of the walking belt will adjust to zero. Push PAUSE/STOP to end the Cool Down period. After the Cool Down period, the Console will show the Workout Results for an additional 5 minutes. Push PAUSE/STOP to end the Results Mode and go back to Power-Up Mode. If there is no input to the Console for 5 minutes, the Console automatically goes into Sleep Mode.

Read all maintenance instructions fully before you start any repair work. In some conditions, an assistant is required to do the necessary tasks.

**!** Equipment must be regularly examined for damage and repairs. The owner is responsible to make sure that regular maintenance is done. Worn or damaged components must be repaired or replaced immediately. Only manufacturer supplied components can be used to maintain and repair the equipment.

If at any time the Warning labels become loose, unreadable or dislodged, replace the labels. If purchased in US/Canada, contact Customer Service for replacement labels. If purchased outside US/Canada, contact your local distributor for them.

**DANGER** To reduce the risk of electrical shock or unsupervised usage of the equipment, always unplug the power cord from the wall outlet and the machine and wait 5 minutes before cleaning, maintaining or repairing the machine. Place the power cord in a secure location.

**Daily:** Before each use, examine the exercise machine for loose, broken, damaged, or worn parts. Do not use if found in this condition. Repair or replace all parts at the first sign of wear or damage, except for the Walking Deck. The Walking Deck is designed for wear on both sides of it. If only one side of the Walking Deck is worn, a replacement Deck is not required. It is recommended that a qualified service technician is used to flip the Walking Deck. After each workout, use a damp cloth to wipe your machine and Console free of moisture.

**!** With the Walking Deck lowered, if an edge of the Walking Belt can be seen adjust it until the edge is not viewable.

**Note:** Avoid excessive moisture on the Console.

**Weekly:** Check for smooth roller operation. Wipe the machine to remove dust, dirt, or grime.

**!** Do not remove the Motor Cover, as dangerous voltages and moving parts are present. The components are serviceable only by approved service personnel or by following service procedures supplied by Nautilus, Inc.

**Note:** Do not use petroleum based products.

**Monthly or after 20 hours:** Make sure all bolts and screws are tight. Tighten as necessary.

**Quarterly:** Or after 25 hours - Lubricate the walking belt with 100% silicone lubricant (not included with the machine).

**!** Silicone lubricant is not intended for human consumption. Keep out of reach of children. Store in a safe place.

**NOTICE:** Do not clean with a petroleum based solvent or an automotive cleaner. Be sure to keep the Console free of moisture.

## Cleaning

**DANGER** To reduce the risk of electrical shock, always unplug the power cord and wait 5 minutes before cleaning, maintaining or repairing this machine.

Wipe the treadmill down after each use to keep the treadmill clean and dry. It may be necessary to use a mild detergent at times to remove all dirt and salt from the belt, painted parts and the display.

**NOTICE:** To prevent damage to the finish of the machine or Console, do not clean with a petroleum based solvent. Do not apply too much moisture to the Console.

## Adjusting the Belt Tension

If the walking belt starts to slip during use, it is necessary to adjust the tension. Your treadmill has tension bolts at the rear of the treadmill.

1. Before you adjust the belt tension, start the treadmill by pushing the START button.

**!** Be sure not to touch the walking belt or step on the power cord. Keep bystanders and children away from the product you are servicing at all times.

2. Use a 6 mm hex key to turn the right and left belt adjustment bolts clockwise a 1/2 turn, first one bolt and then the other bolt until the belt does not slip.

3. After you adjust each side the 1/2 turn, do a test to see if the belt stopped slipping. If the belt still slips, do steps 2 and 3 again.

If you turn one side more than the other, the belt will move away from that side of the treadmill and may need realignment.

**NOTICE:** Too much tension on the belt causes unnecessary friction and wears the belt, motor and electronics.

4. Push PAUSE/STOP twice to stop the walking belt and end the Quick Start workout.

## Aligning the Walking Belt

The walking belt should be centered on your treadmill at all times. Running style and a non-level surface can cause the belt to move off center. Minor adjustments to the 2 bolts at the rear of the treadmill are necessary when the belt is off center.

1. Push the START button to start the walking belt.

**⚠ Be sure not to touch the walking belt or step on the power cord. Keep bystanders and children away from the product you are servicing at all times.**

2. Stand at the rear of the treadmill to see which direction the belt moves.
3. If the belt moves to the left, turn the left belt adjustment bolt 1/4 turn clockwise and the right belt adjustment bolt 1/4 turn counterclockwise.

If the belt moves to the right, turn the left adjustment bolt 1/4 turn counterclockwise and the right adjustment bolt 1/4 turn clockwise.

4. Monitor the path of the belt for approximately 2 minutes. Continue to adjust the bolts until the walking belt is centered.
5. Push PAUSE/STOP twice to stop the walking belt and end the Quick Start workout.

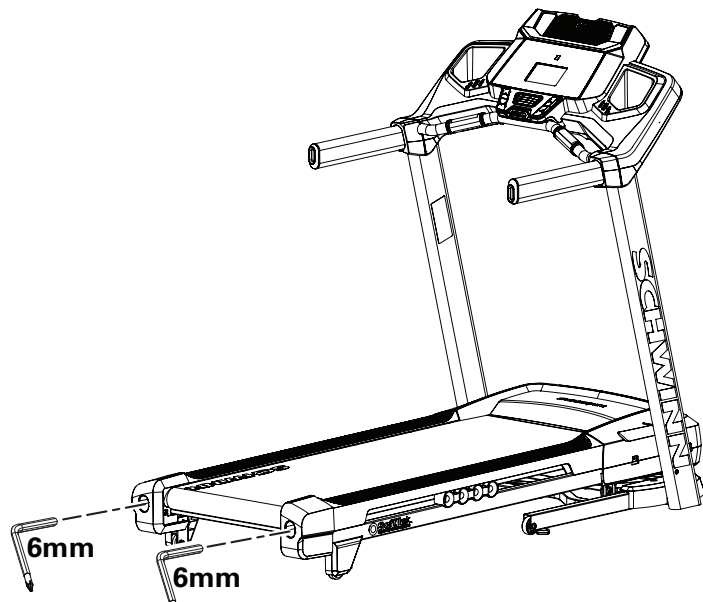

## Lubricating the Walking Belt

Your treadmill is equipped with a low maintenance deck and belt system. The Walking Belt is pre-lubricated. Belt friction can affect the function and life of the machine. Lubricate the belt every 3 months or every 25 hours of use, whichever comes first. Even if the treadmill is not in use, silicone will dissipate and the belt will dry out. For the best results, lubricate the deck periodically with a silicone lubricant using the following instructions:

1. Turn off the power to the machine with the power switch.
2. Unplug the treadmill fully from the wall outlet, and remove the power cord from the machine.

**⚠ DANGER**

**To reduce the risk of electrical shock, always unplug the power cord and wait 5 minutes before cleaning, maintaining or repairing this machine. Place the power cord in a secure location.**

**Note:** Make sure the treadmill is located on a surface that is easy to clean.

3. Apply a few drops of the lubricant on the deck below the belt. Carefully lift the belt and apply a few drops of the lubricant the entire width of the belt. A very thin layer of silicone lubricant on the entire deck below the belt is desired.

**NOTICE:** Always use a 100% pure silicone lubricant. Do not use a degreaser like WD-40® as this could seriously impact performance. We can recommend that you use the following:

- 100% pure silicone, available at most hardware and auto parts stores.
- Lube-N-Walk® Treadmill Lubrication Kit, available from your local specialty fitness dealer or Nautilus, Inc.

**⚠ Silicone lubricant is not intended for human consumption. Keep out of reach of children. Store in a safe place.**

4. Manually rotate the belt 1/2 of the length of the belt and apply lubricant again.

**⚠ If you used spray lubricant, wait 5 minutes before turning on power to the machine to allow the aerosol to dissipate.**

5. Connect the power cord back into the machine and then into the wall outlet.
6. Turn on the power to the machine with the power switch.
7. Stay to one side of your machine and start the belt at the slowest speed. Let the belt operate for approximately 15 seconds.

**⚠ Be sure not to touch the walking belt or step on the power cord. Keep bystanders and children away from the product you are servicing at all times.**

8. Switch off your machine.
9. Take care to clean up any excess lubricant from the deck.

**⚠ To decrease the possibility of slipping, be sure the deck area is free from grease or oil. Clean off any excess oil from the machine surfaces.**

As you use your fitness machine, the Console will show "LUBRICATE BELT" followed by "REVIEW USER MANUAL" at set times. This is only a reminder and should be added to your inspection schedule. Only apply lubricant as necessary. Push any button to accept the reminder.







### Who Is Covered

This warranty is valid only to the original purchaser and is not transferable or applicable to any other person(s).

### What Is Covered

Nautilus, Inc. warrants that this product is free from defects in materials and workmanship, when used for the purpose intended, under normal conditions, and provided it receives proper care and maintenance as described in the Product's Assembly and Owner's manual. This warranty is good only for authentic, original, legitimate machines manufactured by Nautilus, Inc. and sold through an authorized agent and used in the United States or Canada.

### Terms

Warranty terms for products purchased in US/Canada are as stated below.

- Frame 10 years
- Drive Motor 10 years
- Mechanical parts 1 year
- Electronics 1 year
- Labor 1 year

(Labor support does not include the installation of replacement parts involved in the initial product assembly and preventative maintenance services. All repairs covered under the labor portion of the warranty must be preauthorized by Nautilus.)

For warranty & service of products purchased outside US/Canada, please contact your local distributor. To find your local international distributor, go to: [www.nautilusinternational.com](http://www.nautilusinternational.com)

### How Nautilus Will Support the Warranty

Throughout the terms of the warranty coverage, Nautilus, Inc. will repair any machine that proves to be defective in materials or workmanship. Nautilus reserves the right to replace the product in the event a repair is not possible. When Nautilus determines replacement is the correct remedy, Nautilus may apply a limited credit reimbursement toward another Nautilus, Inc. brand Product, at our discretion. This reimbursement may be prorated based on length of ownership. Nautilus, Inc. provides repair service within major metropolitan areas. Nautilus, Inc. reserves the right to charge the consumer for travel outside these areas. Nautilus, Inc. is not responsible for dealer labor or maintenance charges beyond the applicable warranty period(s) stated herein. Nautilus, Inc. reserves the right to substitute material, parts or products of equal or better quality if identical materials or products are not available at the time of service under this warranty. Any replacement of the product under the terms of the Warranty in no way extends the original Warranty period. Any limited credit reimbursement may be prorated based on length of ownership. THESE REMEDIES ARE THE EXCLUSIVE AND SOLE REMEDIES FOR ANY BREACH OF WARRANTY.

### What You Must Do

- Retain appropriate and acceptable Proof of Purchase.
- Operate, maintain, and inspect the Product as specified in the Product Documentation (Assembly, Owner's Manuals, etc.).
- Product must be used exclusively for the purpose intended.
- Notify Nautilus within 30 days after detecting an issue with the Product.
- Install replacement parts or components in accordance with any Nautilus instructions.
- Perform diagnostic procedures with a trained Nautilus, Inc representative if requested.

### What Is Not Covered

- Damage due to abuse, tampering or modification of the Product, failure to properly follow assembly instructions, maintenance instructions, or safety warnings as stated in the Product Documentation (Assembly, Owner's Manuals, etc), damage due to improper storage or the effect of environmental conditions such as moisture or weather, misuse, mishandling, accident, natural disasters, power surges.
- A machine placed or used in a commercial or institutional setting. This includes gyms, corporations, work places, clubs, fitness centers and any public or private entity that has a machine for use by its members, customers, employees or affiliates.
- Damage caused by exceeding maximum user weights as defined in the Product's Owner's manual or warning label.
- Damage due to normal usage and wear and tear.
- This warranty does not extend to any territories or countries outside the United States and Canada.

### How to Obtain Service

For Products purchased directly from Nautilus, Inc. contact the Nautilus office listed on the Contacts page of the products Owner's manual. You may be required to return the defective component to a specified address for repair or inspection, at your expense. Standard ground shipping of any warranty replacement parts will be paid by Nautilus, Inc. For products purchased from a retailer, you may be asked to contact your retailer for warranty support.

### Exclusions

The preceding warranties are the sole and exclusive express warranties made by Nautilus, Inc. They supersede any prior, contrary or additional representations, whether oral or written. No agent, representative, dealer, person or employee has the authority to alter or increase the obligations or limitations of this warranty. Any implied warranties, including the WARRANTY OF MERCHANTABILITY and any WARRANTY OF FITNESS FOR A PARTICULAR PURPOSE, are limited in duration to the term of the applicable express warranty provided above, whichever is longer. Some states do not allow limitations on how long an implied warranty lasts, so the above limitation may not apply to you.

### Limitation of Remedies

EXCEPT AS OTHERWISE REQUIRED BY APPLICABLE LAW, THE PURCHASER'S EXCLUSIVE REMEDY IS LIMITED TO REPAIR OR REPLACEMENT OF ANY COMPONENT DEEMED BY NAUTILUS, INC. TO BE DEFECTIVE UNDER THE TERMS AND CONDITIONS STATED HEREIN. IN NO EVENT WILL NAUTILUS, INC. BE LIABLE FOR ANY SPECIAL, CONSEQUENTIAL, INCIDENTAL, INDIRECT OR ECONOMIC DAMAGES, REGARDLESS OF THE THEORY OF LIABILITY (INCLUDING, WITHOUT LIMITATION, PRODUCT LIABILITY, NEGLIGENCE OR OTHER TORT) OR FOR ANY LOST REVENUE, PROFIT, DATA, PRIVACY OR FOR ANY PUNITIVE DAMAGES ARISING OUT OF OR RELATED TO THE USE OF THE FITNESS MACHINE EVEN IF NAUTILUS, INC. HAS BEEN ADVISED OF THE POSSIBILITY OF SUCH DAMAGES. THIS EXCLUSION AND LIMITATION SHALL APPLY EVEN IF ANY REMEDY FAILS OF ITS ESSENTIAL PURPOSE. SOME STATES DO NOT ALLOW THE EXCLUSION OR LIMITATION OF CONSEQUENTIAL OR INCIDENTAL TYPE DAMAGES SO THE ABOVE LIMITATION MAY NOT APPLY TO YOU.

### State Laws

This warranty gives you specific legal rights. You may also have other rights, which vary from state to state.

### Expirations

If the warranty has expired, Nautilus, Inc. may assist with replacements or repairs to parts and labor, but there will be a charge for these services. Contact a Nautilus office for information on post-warranty parts and services. Nautilus does not guarantee availability of spare parts after expiration of warranty period.

### International Purchases

If you purchased your machine outside of the United States consult your local distributor or dealer for warranty coverage.



Nautilus, Inc., 5415 Centerpoint Parkway, Groveport, OH 43125 USA, [www.NautilusInc.com](http://www.NautilusInc.com) - Customer Service: North America (800) 605-3369, [csnls@nautilus.com](mailto:csnls@nautilus.com) | Nautilus (Shanghai) Fitness Equipments Co, Ltd, Room 1701 &1702, 1018 Changning Road, Changning District, Shanghai, China 200042, [www.nautilus.cn](http://www.nautilus.cn) - 86 21 6115 9668 | outside U.S. or Canada: [www.nautilusinternational.com](http://www.nautilusinternational.com) | Printed in China | © 2019 Nautilus, Inc. | Schwinn, the Schwinn Quality logo, Schwinn 810, Schwinn 510T, Bowflex, JRNY, and Nautilus are trademarks owned or licensed by Nautilus, Inc., registered or otherwise protected by common law in the United States and other nations. Google Play is a trademark of Google Inc. App Store is a service mark of Apple Inc. The Bluetooth® word mark and logos are registered trademarks owned by Bluetooth SIG, Inc., and any use of such marks by Nautilus, Inc. is under license.



ORIGINAL MANUAL - ENGLISH VERSION ONLY

