

# Max Trainer M7: My machine is seized, why won't it move?

ID: 10978.1

Follow this troubleshooting guide to help resolve issues involving a seized-up Max Trainer M7.

Some common complaints may include:

- Pedals are stuck and won't move
- Fan making contact with the motor or frame
- Jammed upper or lower belts

## **Pedals are stuck and won't move**

*Tools you may need:*

Phillips head screwdriver  
5mm, 6mm hex/Allen wrenches, or wrenches from the hardware card included with your machine  
14mm socket wrench  
Crank puller (if removing crank arms for troubleshooting)  
Flashlight

1. Check that the crank arms are opposite each other 180 degrees (**reference 1**). If the crank arms are not in line and opposite each other, reorient the crank arms. Refer to the "Replace the Crank Arms" section of the [service manual \[10978.A\]](#).

### (Reference 1)

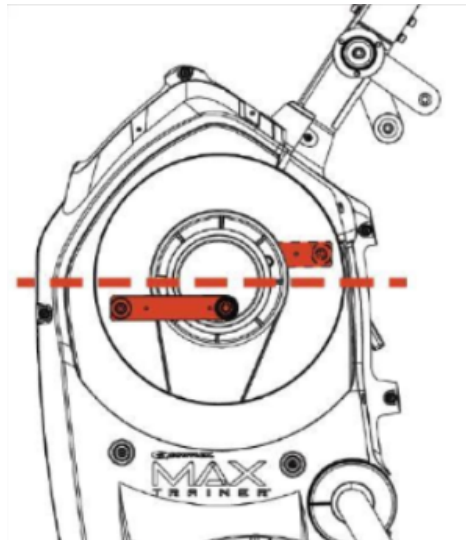

*Diagram showing how the crank arms should be oriented when properly installed.*

2. Check if the crank arms can be rotated by hand. Applying weight to the raised foot pedal can help with pedals that have bottomed out [\[10978.B\]](#).
3. Remove the lower right fan shroud. Watch the video below or follow the instructions starting in the next step.

## Bowflex® Max Trainer | Removing Lower Right Fan Shroud



### [\(BowFlex® Max Trainer | Removing Lower Right Fan Shroud\)](#)

- Using a Phillips head screwdriver, carefully loosen the bottom screw by at least 3 turns and remove the 3 upper screw attaching the cover. The power plug wire inlet is attached to the inside and needs to be gently unplugged before completely removing the cover (**reference 2**). It may help if you tilt the machine gently to the side to loosen the bottom screw.

#### (Reference 2)

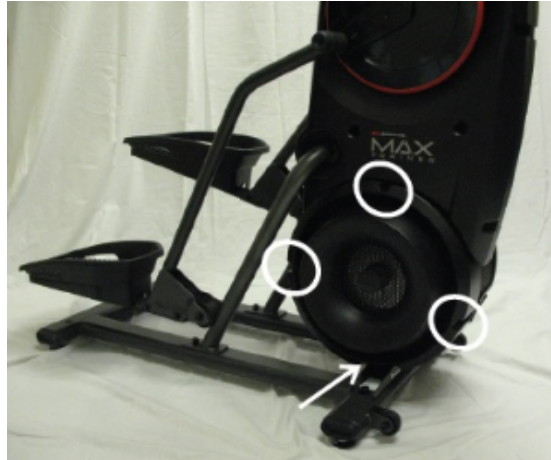

*The white circles indicate the location of the 3 upper screws to remove. The white arrow indicates the location of the power plug inlet wire and bottom screw. Loosen the bottom screw by at least 3 turns, unplug the power inlet wire, then remove the cover.*

- Check if the brake magnets are stuck to the brake disc. If the magnets are stuck to the brake disc, please visit [Max Trainer M7: My machine is making a metallic grinding or scraping noise](#) to continue troubleshooting.
- If the issue persists, attempt to spin the fan by hand back and forth. Inspect the 4 round magnets located on the fan. If these magnets are making contact with the motor or the frame, [order an M7 engine \[10978.C\]](#).
- Inspect the lower belt for damage. If damage is present or has become jammed in the frame, [order a Lower Belt \[10978.D\]](#).

- **IMPORTANT:** machines produced before July 2014 used a lower belt tensioner. The replacement lower belt is self-tensioning. When installing the replacement lower belt on these units, remove and dispose of the tensioner. This does not apply to upper belts.

8. Inspect the upper belt for damage. Remove the left pedal arm and left side crank cover. Doing so will expose the left crank and the upper belt pulley. If the upper belt is damaged or has become jammed in the frame, [order an Upper Belt \[10978.E\]](#).

### **Need to order replacement parts?**

## 1 Customer Care Contact Information

**Please contact Customer Care at 1-800-605-3369 for additional help or to order replacement parts. Some replacement parts may also be available for purchase [online here](#). A list of part numbers referenced within this guide can be located at the bottom of this page.**

**Customer Care - Hours of Operation:**  
Monday - Friday 6:00am - 5:00pm PST

The replacement part will be provided to you at no cost assuming your machine meets the warranty eligibility requirements. A Customer Care Agent will be able to assess your current warranty eligibility and provide you with your options.  
Please note that if you did not purchase your machine directly from BowFlex, Schwinn, or Nautilus, we will need a copy of your purchase receipt in order to register your machine for warranty.

## 2 Parts Reference Table

<i>Part Description</i>	<i>Part SKU</i>
<b>Lower Belt</b>	<b>8006063</b>
<b>M7 Engine</b>	<b>8016602</b>
<b>Upper Belt</b>	<b>8004642</b>

## 3 Contact Tech Team / Advanced Troubleshooting

**If the issue was not resolved in the steps listed, contact the Tech Team or send an Advanced Troubleshooting case.**

**Submit a Case with case type [Advanced Troubleshooting](#)**