

LateralX Machines: Clicking, clunking, clacking, and grinding noises

Follow this troubleshooting guide to help resolve noise issues on the BowFlex LateralX LX3, LX5, and LX5+. Please note there will be general mechanical noises present during workouts due to the complicated nature of the machine. These noises can become more noticeable or increase at higher speeds and/or wider stride widths (LX5 and LX5+ models only).

Some common complaints may include:

- Clicking/clunking/clacking/grinding noises

Follow these steps to troubleshoot the issue

Tools you may need:

Phillips head screwdriver
6mm, 10mm hex/Allen wrench, or the wrench from the hardware card included with your machine
Lateral link puller (if removing lateral links for troubleshooting)

1. Refer to Step 6 "Attach Pedal Arms to Crank Arms" in the [assembly manual](#). Verify that the pedal arm is seated on the stepped/collared washer completely. The top of the washer should be visible but flush with the hole on the pedal arm before adding any hardware (**reference 1**). With the pedal arms in place, confirm all other parts are in their correct places. If needed, reinstall the pedal arms with a Phillips head screwdriver and a 6mm/10mm Allen wrench. Refer to the "Replace the Pedal Arms and Pedal Shrouds" section of the [service manual](#) if additional instructions are needed. Once proper part locations are verified/the pedals are reinstalled, plug your machine back in and operate it at a low speed and low resistance. Listen to see if the noise persists [\[13932.A\]](#).

(Reference 1)

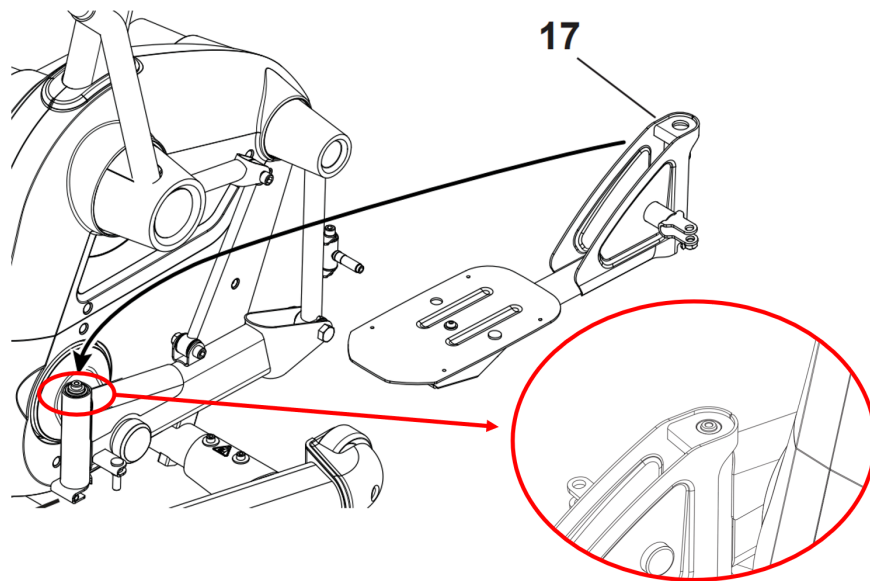

*The top of the collared washer should be visible through the hole on the pedal arm.
Refer to the assembly manual if more detailed instructions are required.*

2. If the noise persists, double-check the hardware on the external links (**references 2 through 4**). If the hardware seems loose, tighten using a 6mm and 10mm Allen wrench. Once the hardware is tightened, test to see if the issue persists [\[13932.B\]](#).

(Reference 2)

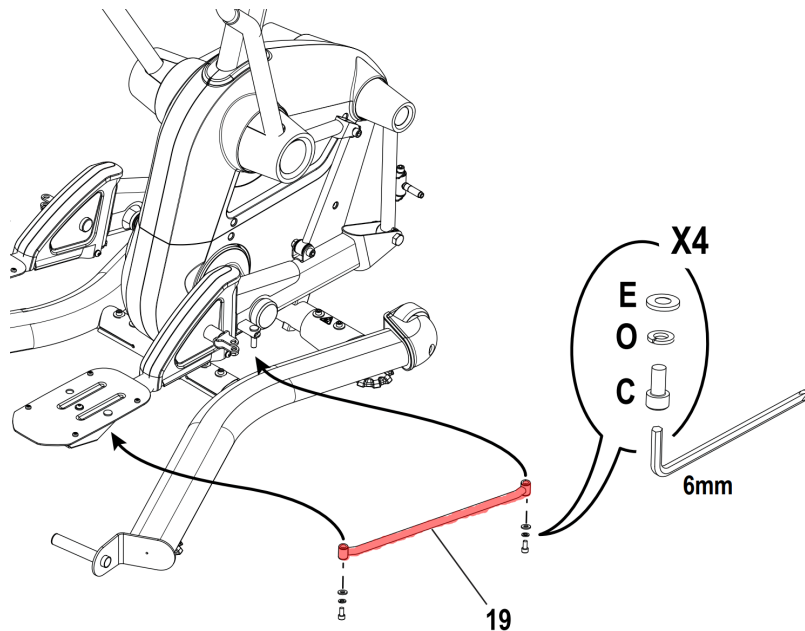

The right-side parallel link is highlighted in red. Tighten the hardware shown on both sides. One screw is inserted underneath the foot pedal (left arrow) and the other is inserted into the side bracket on the crank arm (right arrow).

(Reference 3)

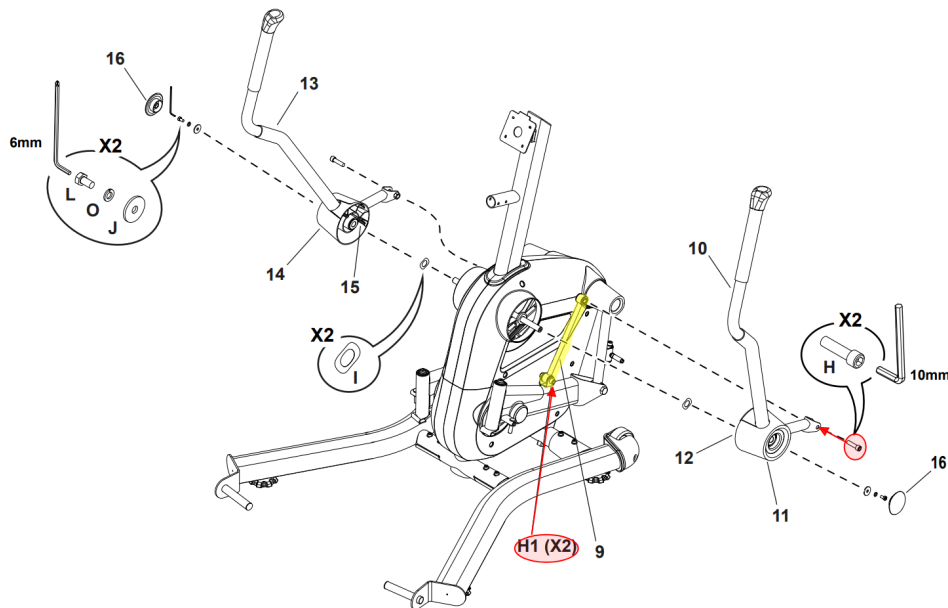

The right-side handlebar link is highlighted in yellow. Tighten the hardware circled in red on both sides.

(Reference 4)

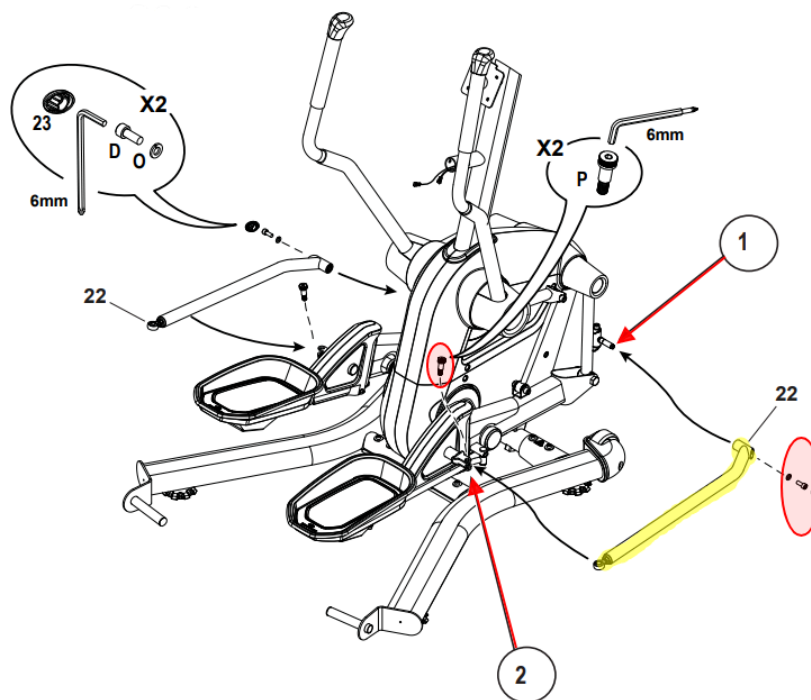

The right-side lateral link is highlighted in yellow. Tighten the hardware circled in red on both sides. One screw is inserted into the pedal arm assembly (left hardware) and the other is installed on the cram arm (right hardware).

3. If the issue persists, rotate the pedal arms and listen to where the noise is coming from. You should listen to each joint and try to isolate the noise. It may be helpful to have a second person to assist while performing this step. If you are having difficulty isolating the source of the noise, you can very carefully touch potentially affected parts to feel for abnormal vibration or clicking. Please note, if you do feel for affected areas, be aware of and avoid pinch points/moving parts that may cause injury.
4. If the noise comes from a pedal arm, [order a Left or Right Pedal Arm](#) (whichever side is affected) [\[13932.C\]](#)
5. If the noise comes from a handlebar link, [order a Handlebar Link](#) [\[13932.D\]](#).

6. If the noise comes from a parallel link, [order a Parallel Link \[13932.E\]](#).

7. If the noise comes from a lateral link, [order a Lateral Link \[13932.F\]](#).

- o **Important:** a lateral link puller is required to replace the lateral link. [Order a Lateral Link Puller](#) if you do not already have one.

Need to order replacement parts?

1 Parts Reference Table

<i>Part Description</i>	<i>Part SKU</i>
LX3	
Handlebar Link	8014280
Lateral Link	8014387
Link Puller	8018723
Parallel Link	8014284
Pedal Arm, Left	8014275
Pedal Arm, Right	8014276
LX5, LX5+	
Handlebar Link	8014460
Lateral Link	8013468
Link Puller	8018723
Parallel Link	8014285
Pedal Arm, Left	8013452
Pedal Arm, Right	8013463

2 Contact Tech Team / Advanced Troubleshooting

If the issue was not resolved in the steps listed, contact the Tech Team or send an Advanced Troubleshooting case.

[Submit a Case](#) with case type [Advanced Troubleshooting](#)