

 **BOWFLEX**  
**REVOLUTION**



**The Bowflex Revolution®**  
**Owner's Manual**



POWERED BY  
**SPIRAFLEX™**

# Table of Contents

Important Safety Information	1	Warming Up	22
Safety Warning Labels and Serial Number	2	Aerobic Rowing Position	22
Specifications	4	Breathing	22
Getting to Know Your Bowflex Revolution® Home Gym	5	Performing Your Routine	22
		Cool Down	22
Using Your Bowflex Revolution® Home Gym		The Workouts	23
SpiraFlex® Resistance	6	20 Minute Better Body Workout	23
Adjusting and Understanding the Resistance	6	Advanced General Conditioning	23
Attaching SpiraFlex® Resistance Plates	7	20 Minute Upper/Lower Body	24
Preparing for Use, Storing, and Moving	8	Body Building	25
Maintenance	9	Circuit Training – Anaerobic/Cardiovascular	26
Adjusting Cable Tension	11	True Aerobic Circuit Training	27
Cable Hookup for Leg Exercises	11	Strength Training	28
Cable Hookup for Leg Press Exercises	12	Exercises	29
Storing Leg Press Cables	13	Chest Exercises	30
Storing Leg Extension Cables	14	Shoulder Exercises	39
Attaching Hand Grips and Foot Harnesses	15	Back Exercises	50
Attaching Accessories, Benches and Seats	16	Arm Exercises	58
Leg Press Seatback	16	Abdominal Exercises	69
Leg Press Plate	16	Leg Exercises	73
Preacher Curl	17	Muscle Chart	82
Multi-Position Bench	17	Exercise Log	83
Companion Equipment	19	Body Weight Loss Guide	84
Defining Goals	20	Bowflex Revolution® 100% Satisfaction Guarantee	93
Reaching Your Goals	21		
Designing Your Own Program	21		
Exercising Properly	22		
Working Out	22		

**To validate warranty support, keep the original proof of purchase and record the following information:**

**Serial Number** \_\_\_\_\_ **Date of Purchase** \_\_\_\_\_

To register your product warranty, go to: [www.bowflex.com/register](http://www.bowflex.com/register)

Or call 1 (800) 605-3369.

If you have questions or problems with your product, please call 1 (800) 605-3369.

Nautilus, Inc., (800) NAUTILUS / (800) 628-8458, [www.NautilusInc.com](http://www.NautilusInc.com) - Customer Service: North America (800) 605-3369, [customerservice@bowflex.com](mailto:customerservice@bowflex.com) | outside U.S. +01-360-859-5180, [technics-APLA@nautilus.com](mailto:technics-APLA@nautilus.com) | Printed in China | © 2005 Nautilus, Inc., All rights reserved. ™ and ® indicate a trademark or registered trademark. Nautilus, Inc. ([www.NautilusInc.com](http://www.NautilusInc.com)) trademarks include NAUTILUS®, BOWFLEX®, SCHWINN® and UNIVERSAL® and respective logos. Other trademarks are the property of their respective owners.

# Important Safety Instructions

---



Indicates a potentially hazardous situation which, if not avoided, could result in death or serious injury.

## Before using this equipment, obey the following warnings:



Read and understand the complete Owner's Manual. Keep Owner's Manual for future reference.

Read and understand all warnings on this machine. If at any time the Warning stickers become loose, unreadable or dislodged, contact Nautilus<sup>®</sup> Customer Service for replacement stickers.

- Children must not be let on or near to this machine. Moving parts and other features of the machine can be dangerous to children.
- Not intended for use by anyone under 14 years of age.
- Consult a physician before you start an exercise program. Stop exercising if you feel pain or tightness in your chest, become short of breath, or feel faint. Contact your doctor before you use the machine again.
- Before each use, examine this machine for loose parts or signs of wear. Inspect all cables, pulleys and their connections, making sure they are properly secured and attached, and show no signs of visible wear or damage. Contact Nautilus<sup>®</sup> Customer Service for repair information.
- Maximum user weight limit: 300 lb. (136 kg). Do not use if you are over this weight.
- This machine is for home use only.
- Do not wear loose clothing or jewelry. This machine contains moving parts. Do not put fingers or other objects into moving parts of the exercise equipment.
- Set up and operate this machine on a solid, level, horizontal surface.
- Do not operate this machine outdoors or in moist or wet locations.
- Keep at least 22" (56 cm) on each side of the machine clear. This is the recommended safe distance for access and passage around and emergency dismounts from the machine. Keep third parties out of this space when machine is in use.
- Do not over exert yourself during exercise. Operate the machine in the manner described in this manual.
- Do not use Dumbbells or other weight equipment to incrementally increase the weight resistance. Use only the weight resistance designed for use with this gym.
- Correctly adjust and safely engage all Positional Adjustment Devices. Make sure that the Adjustment Devices do not hit the user.
- Never adjust the seat while sitting on it. Never stand on the seat.
- Never attempt to exercise while the seat rail is in the folded position.
- Do not move the machine without aid. Injury to you or damage to the machine can occur.

## Safety Warning Labels and Serial Number

Locate and read all safety warnings on the machine before using it. Replace any warning label if it is damaged, illegible, or missing. If you need replacement labels, call a Nautilus Representative.

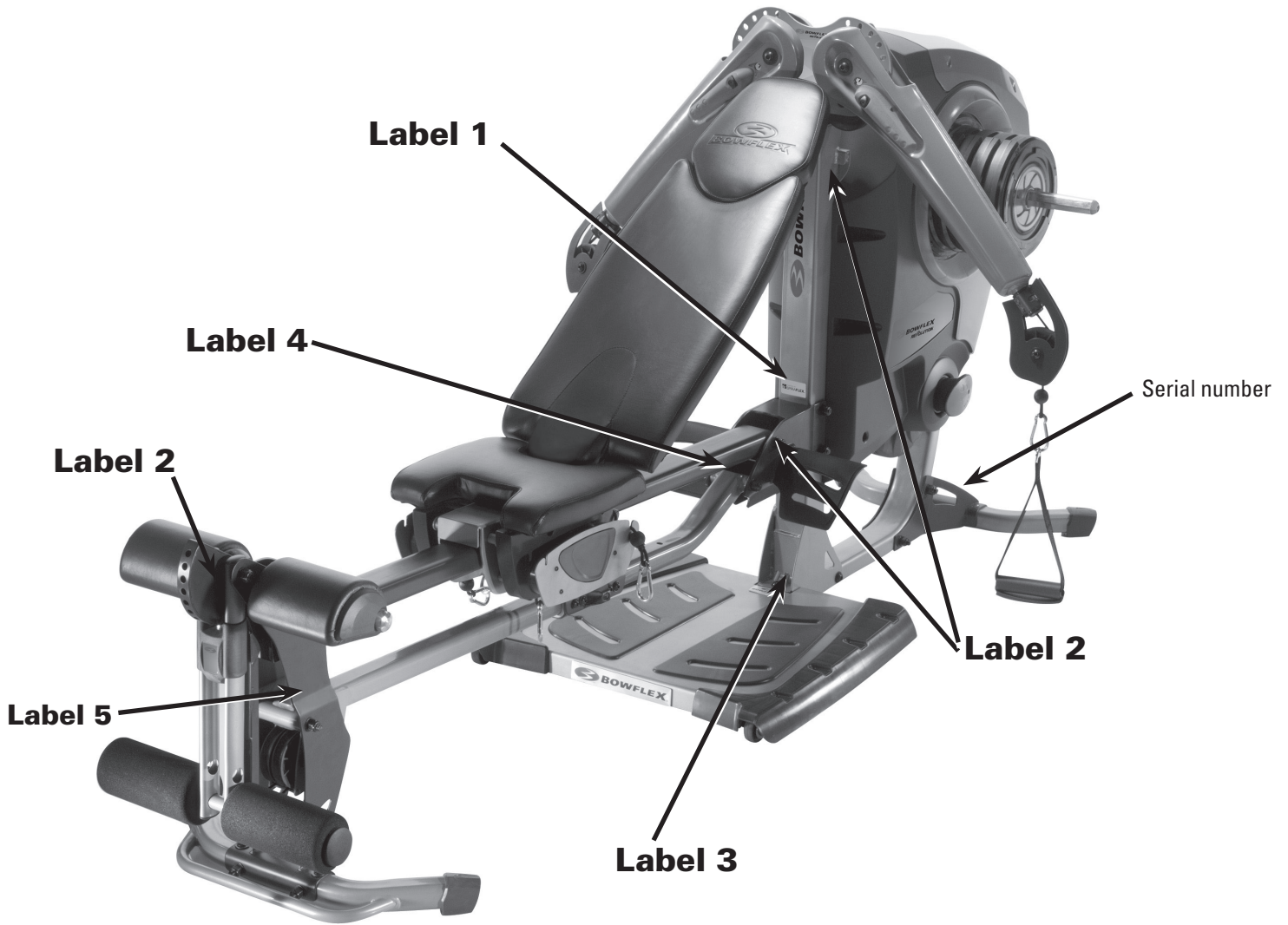

# Safety Warning Labels and Serial Number

**Label 1:** General use safety label.

**Location:** Front of the main unit above seat rail.

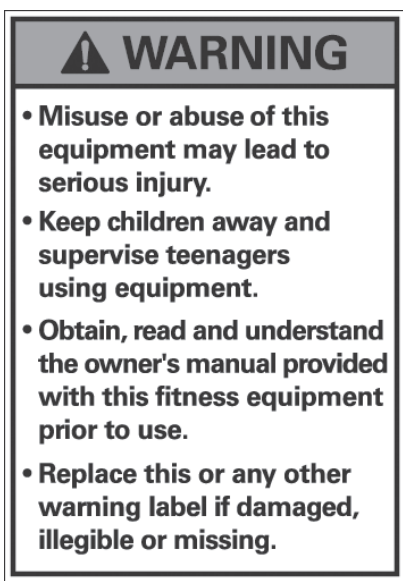

**Label 2:** Keep hands away.

**Location:** Below freearms on main unit; top of seat rail bracket; top of Leg Extension adjustment.



**Label 3:** Check all equipment before use.

**Location:** Bottom front of the main unit.



**Label 4:** Avoid crush hazard when folding the bench.

**Location:** Top of seat rail next to the main unit.



**Label 5:** Keep hands clear when folding.

**Location:** Both sides of the Leg Extension.



## Product Specifications

---

Dimensions (arms raised)	112" L x 37.8" W x 73" H (284cm x 98cm x 185.4cm)
Workout Area	120" x 84" (304.8cm x 213.4cm)
Assembled Unit Weight	336.2 lbs. (152.5 kg)
Shipping Weight	414.64 lbs. (188.1 kg)
SpiraFlex® Resistance	220 lbs. (100 kg)
SpiraFlex® Upgradability	300 lbs. (136 kg)
Maximum User Weight	300 lbs. (136 kg)

## Getting to Know Your Bowflex Revolution® Home Gym

Please take your time to read through the entire manual and follow it carefully before attempting to use your Bowflex Revolution® home gym. Also locate and read all warning labels that are posted on the machine. It's important to understand how to properly perform each exercise before you do so using SpiraFlex® Resistance.

The image below shows the machine set up in just one of many configurations. Included as standard accessories with your new Bowflex Revolution® home gym are a preacher curl attachment, leg press plate, leg press seatback, foot harnesses, and curl/pulldown bar. Instructions for attaching various accessories, storing cables, and changing out bench components are included later in this manual, as well as in the Assembly Manual.

### Bowflex Revolution® Parts Reference Guide

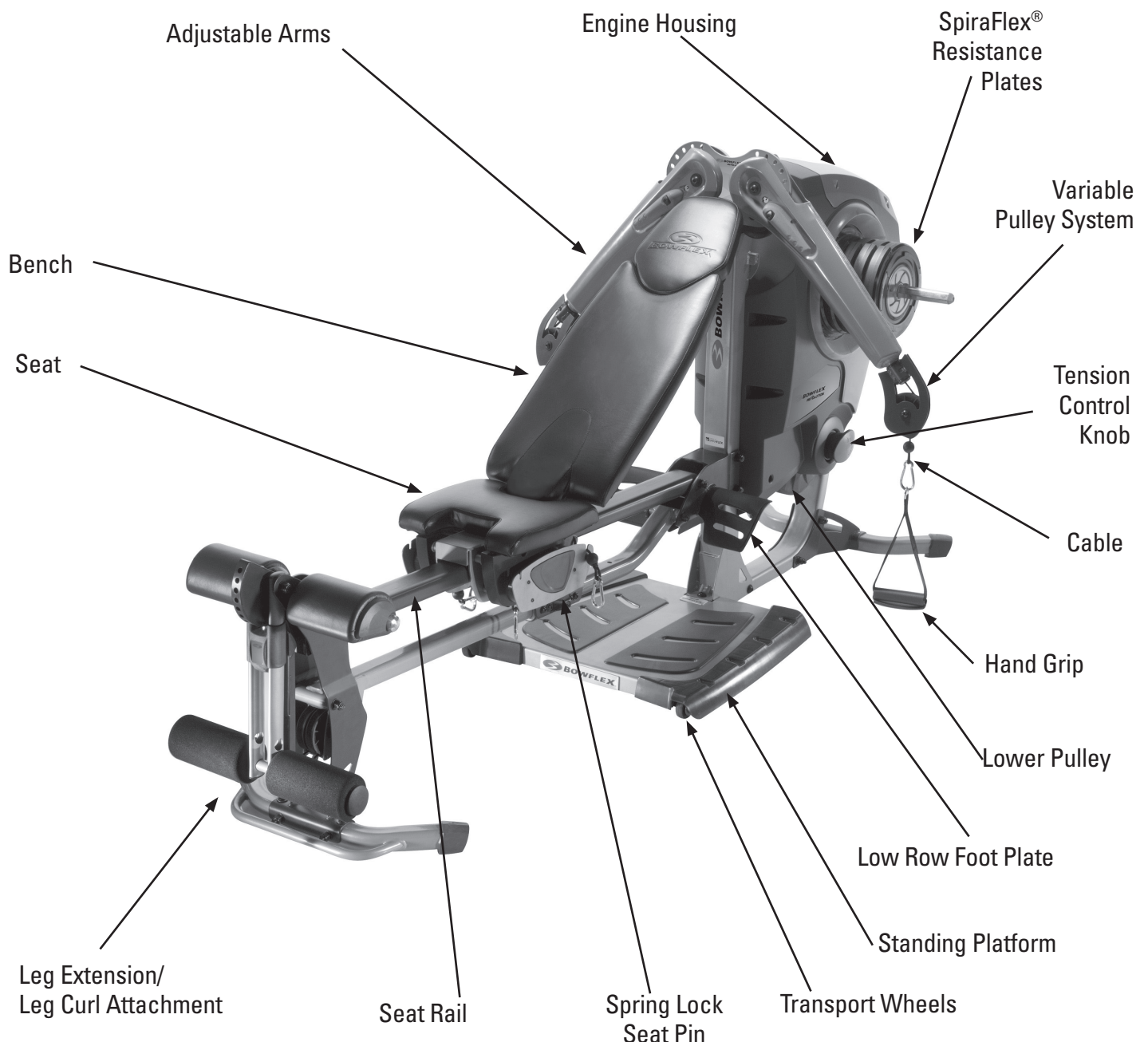

## Using Your Bowflex Revolution® Home Gym

### SpiraFlex® Resistance

The Bowflex Revolution® home gym features an ingenious patented technology called SpiraFlex®. The Bowflex Revolution® muscle-building resistance comes in the form of these cleverly designed resistance packs, each constructed with a heavy-duty elastic strap inside the pack. When you perform an exercise, these resistance packs rotate around the center, stretching the elastic strap and creating resistance.

A significant advantage of the resistance packs is that the resistance is present throughout the ENTIRE range of motion. That gives you a more consistent, gym-quality experience – which means your muscles get a bigger burn, a better workout and faster results.

SpiraFlex® technology is a non-inertial resistance mechanism that provides the smoothness and feel of gym-quality plate-loaded machines, but eliminates the excessive bulk and weight. This totally unique, state-of-the-art resistance system involves wrapping an elastic strap tighter and tighter around a coil, which is contained in a small canister that looks very similar to free weight plates, but weighs only a few pounds. Because no metal parts are used, SpiraFlex® technology is quiet, lightweight, portable, and safe.

### Adjusting and Understanding

#### The Resistance

The Bowflex Revolution® home gym comes with 220 lbs. (100 kg) of resistance. The SpiraFlex® resistance plates look very much like free weight plates and are assigned a pound rating based on their resistance – including 5, 10, 20, and 40-pound packs (2.27kg, 4.54kg, 9.07kg, 18.14kg). The real power of the workout is in the RESISTANCE, not the weight. And that means you can quickly and easily stack these lightweight resistance plates onto the Revolution® – just like free weights – and get a great workout.

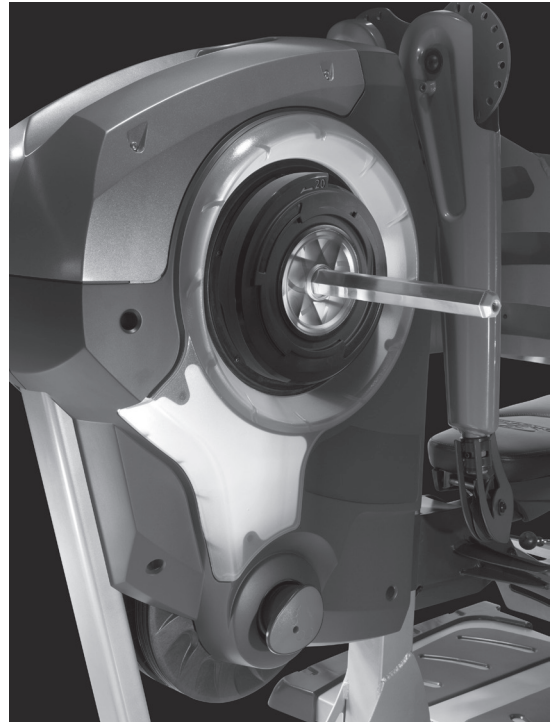

**To upgrade to 300 pounds  
(136 kg) of resistance please  
call 1-800-663-6315**



## Using Your Bowflex Revolution® Home Gym

### Attaching SpiraFlex® Resistance Packs

During assembly, you attached 5-lb (2.27kg) SpiraFlex® resistance packs to the machine. The 5-lb packs are permanently attached to the machine. The Bowflex Revolution® home gym comes with 220 lbs (100kg) of resistance packs in 5, 10, 20, and 40-lb packs (2.27kg, 4.54kg, 9.07kg, 18.14kg).

Attaching resistance packs is simple. You simply select the resistance pack and slide it onto the shaft, making sure the rounded edge of the hole in the plate is matched up with the rounded edge of the shaft (see photos to the right). Once you push the pack all the way onto the shaft, press and turn the plate counterclockwise about 10 degrees until the locking tabs click into place. While applying pressure, turn the plate clockwise until the index marks on the packs are aligned.

**NOTE: It is extremely important to make sure that all six locking tabs engage to ensure proper and safe operation of the machine. Check that the pack is seated evenly, with no extra gap behind the bottom edge of the pack.**

You can choose any combination of resistance packs to suit your needs. Each pack needs to be installed in the same manner, by placing the pack onto the shaft, sliding it all the way to the housing, and turning it counterclockwise until the locking tabs engage. Then turn it clockwise so that the index marks on each pack are aligned. If you are using multiple resistance packs, each one contains locking mechanisms to stack multiple packs.

You can set resistance either symmetrically or offset. What this means is that you can set resistance to 40 lbs (18.14kg) on one side and 60 lbs (27.22kg) on the other side, or set both sides to 60 lbs, or 60 lbs on one side and nothing on the other side--or any variation like that. Setting resistance on one side is useful when doing one-sided exercises such as trunk rotations or hip extensions. You do not always have to have the same amount of resistance on each side. Doing so, however, is common for symmetrical exercises such as bench press or chest fly.

**For an animated demonstration of proper pack installation, visit the FAQ section of the Bowflex Revolution® website at [www.bowflexrevolution.com](http://www.bowflexrevolution.com).**

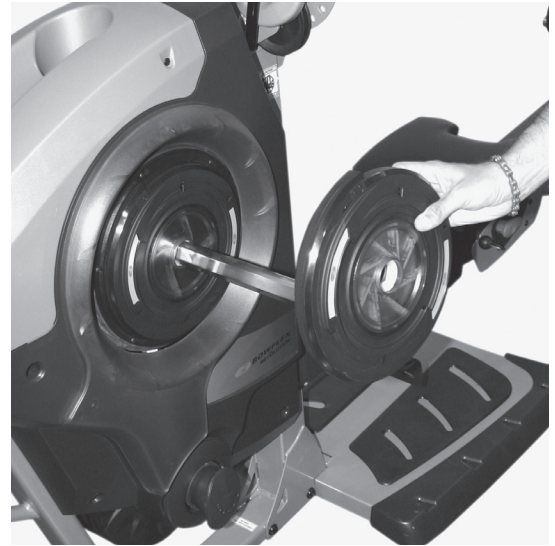

**Step 1: Place resistance plate on shaft, matching rounded top of hole with rounded top of shaft. Push resistance plate all the way onto shaft.**



**Step 2: While pressing pack towards machine, turn counterclockwise about 10 degrees until all six plate tabs lock into place. Then turn clockwise until index marks are aligned.**

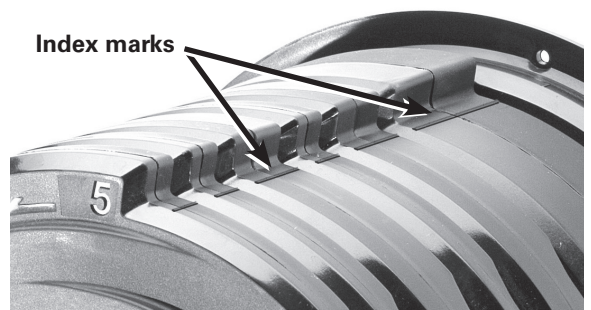

## Preparing for Use, Storing, and Moving

The Bowflex Revolution® home gym has the largest range of exercises ever offered by a Bowflex® home gym. Preparing your machine for use and maintaining your machine are simple.

### Preparing for Use

Before using your Bowflex Revolution® home gym, make sure you read through all of the safety warnings in this manual, and pay close heed to the warning labels on the machine. Additionally, inspect the machine prior to each use to ensure all parts are in good working order.

### Preparing to Exercise

To do exercises, read the instructions in this manual or on the exercise poster included with your machine. Each exercise uses a unique set of adjustable arm positions and cable connections. Using your Bowflex Revolution® home gym should be easy:

- Select the desired resistance plates
- Position the adjustable arms to the correct setting
- Attach cable clips to appropriate location
- Complete the exercise

A full description of each exercise is included later in this manual.

### Moving & Storing Your Machine

The full assembled weight of your machine is in excess of 300lbs. It's imperative that you observe all safety warnings and cautions when using or moving your machine. To move your machine, raise the adjustable arms to the 0 position and make sure they are locked in place. Raise the seat rail system, pull the pop pin on the lower seat rail at the leg extension assembly, and use the handle to lift the seat rail assembly into place. Grasp the handle on the back of the engine, and carefully lift the back of the machine to shift its weight to the transport wheels at the front of the Standing Platform. You can now roll the machine.



To raise seat rail assembly, pull pop pin (see above photo) and lift seat rail assembly until seat rail is upright and pin locks in place..

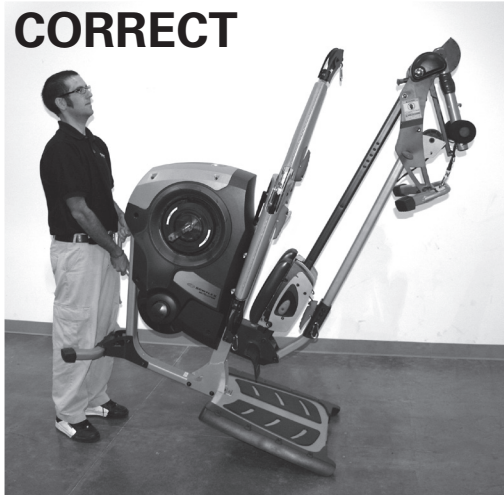



To move the machine, use handle on backside of engine and roll on the wheels integrated into the platform.



DO NOT USE HANDLE ON LEG EXTENSION ASSEMBLY TO MOVE UNIT.

To store your machine, you can either leave it in the fully assembled, extended position, or you can raise the seat rail system to make a smaller footprint for storing. To raise the seat rail system, pull the pop pin on the lower seat rail at the leg extension assembly and use the handle to lift the seat rail assembly into place.

## Preventative Maintenance

-  The safety and integrity designed into a machine can only be maintained when the equipment is regularly examined for damage and repaired. It is the sole responsibility of the owner to ensure that regular maintenance is performed. The owner is responsible to make sure that regular maintenance is done. Worn or damaged components must be repaired or replaced immediately. Only manufacturer supplied components should be used to maintain/repair the equipment.
-  This product, its packaging, and components contain chemicals known to the State of California to cause cancer, birth defects, or reproductive harm. This Notice is provided in accordance with California's Proposition 65. If you would like additional information, please refer to our Web site at [www.nautilus.com/prop65](http://www.nautilus.com/prop65)

Keeping your machine in good repair takes a minimal amount of time, and will ensure you have many years of use. In addition to preventative maintenance such as checking to make sure the unit is clean and free from defects, wiping down surfaces, and keeping attachments in a secure location, maintenance should be limited.

### Daily

Wipe down with a damp cloth. Pay special attention to areas where perspiration could settle.

### Monthly

Inspect the unit for loose parts, nuts, bolts, etc. Inspect ropes and straps for fraying or excessive wear.

### Yearly

Remove the Top Cover and inspect the condition of the internal components.

Look for fraying or excessive wear on straps, ropes, and moving parts, and replace as necessary.

## Adjusting Cable Tension

Pay close attention to maintenance of the cable tension. Over time and with heavy use, the cables are designed to give slightly. Located on the main engine housing is a tension control knob which allows you to increase the tension in the cables.

Checking for problem cable tension is simple.

1. Position the adjustable swing arms in the upper most position.
2. Check to see if clips at end of cable hang down or if they are tight against the pulley.
3. If cables don't have enough tension, use the tension control knob on the side of the machine to tighten the cables. (See image below).
4. To increase tension, pull tension knob outwards and turn the large pulley clockwise. The clip on the cable should be touching the pulley.

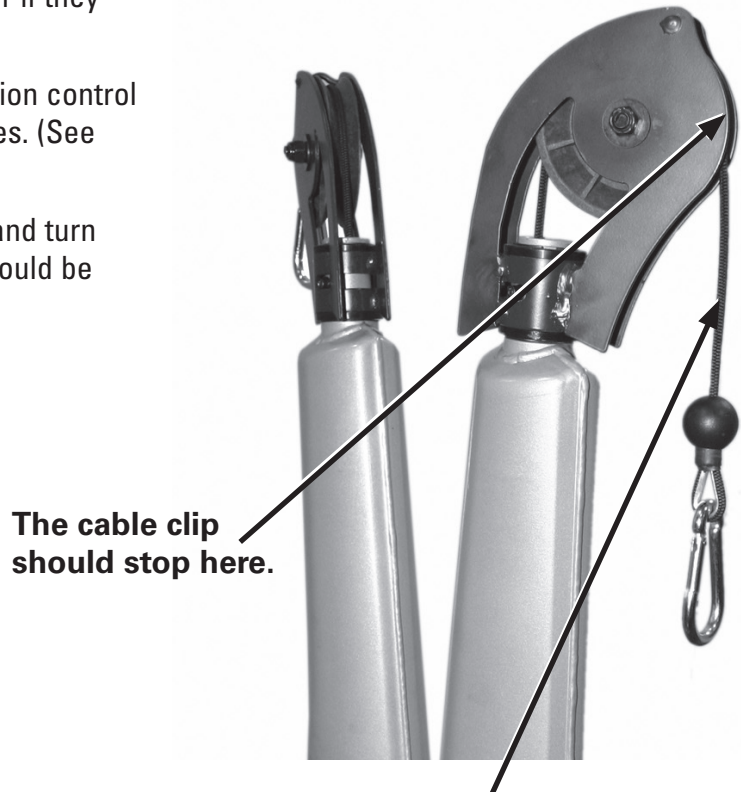

The cable clip should stop here.

In this image, the cable clip extends a few inches below the pulley, so there is not enough tension in the cable. The cable clip should be tight against the pulley with appropriate tension.

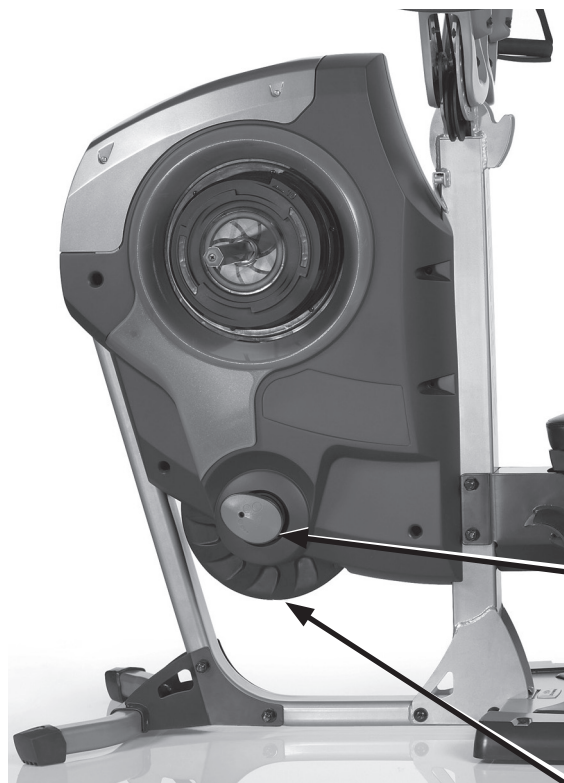

There are tension knobs on each side of the machine. To increase cable tension, pull knob and turn the large pulley clockwise. You'll know when you have enough tension when the cable retracts and the cable clip touches the pulley.

Large pulley. This is what you need to turn to increase the tension on the cable. Pull the tension knob and use your other hand to turn the large pulley clockwise.

The drawings on this page show proper cable hookup when using the leg extension attachment. Please note that the freearms should be in position 9. The included Assembly Manual also contains information on how to attach both cables and machine attachments. Exercise Start and Finish photos on the pages to follow show where machine arms should be positioned, where cables should be attached, and how to position yourself for each exercise.

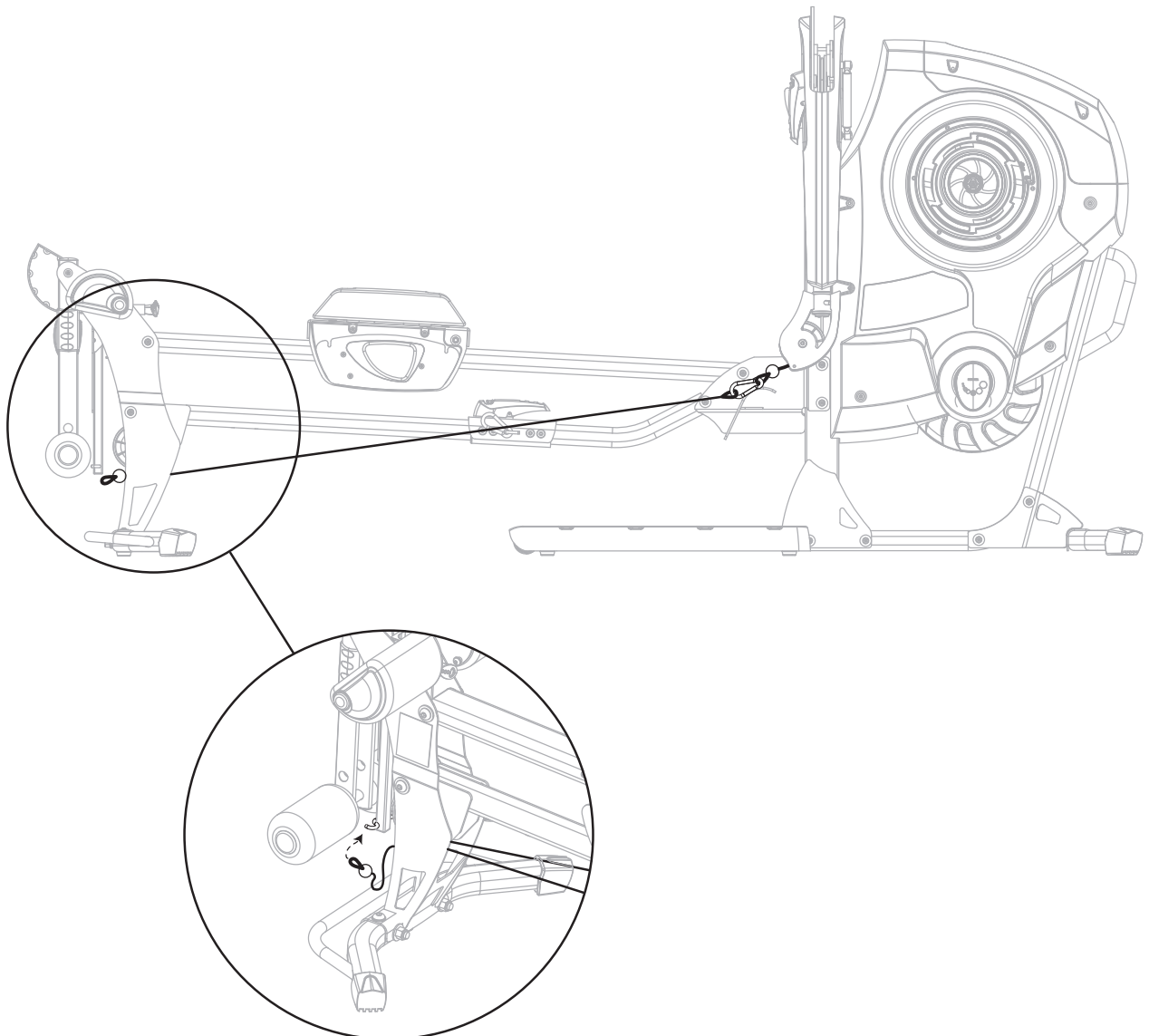
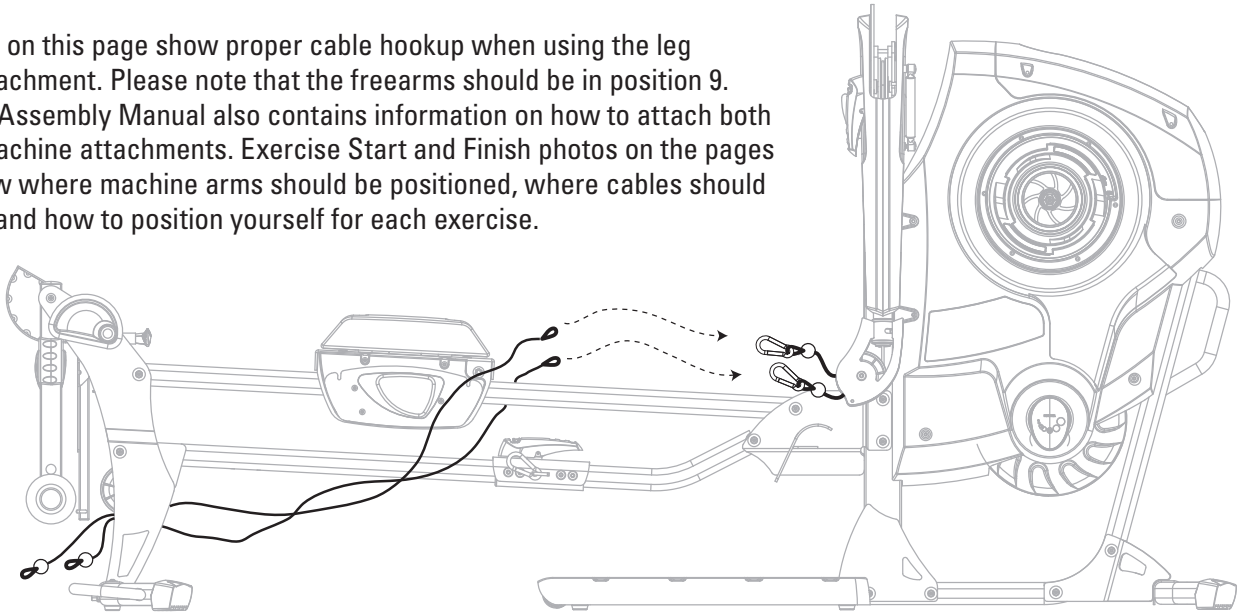

## Cable Hookup for Leg Press Exercises

The drawings on this page show proper cable hookup for leg press exercises. Please note that the freearms should be in position 9.

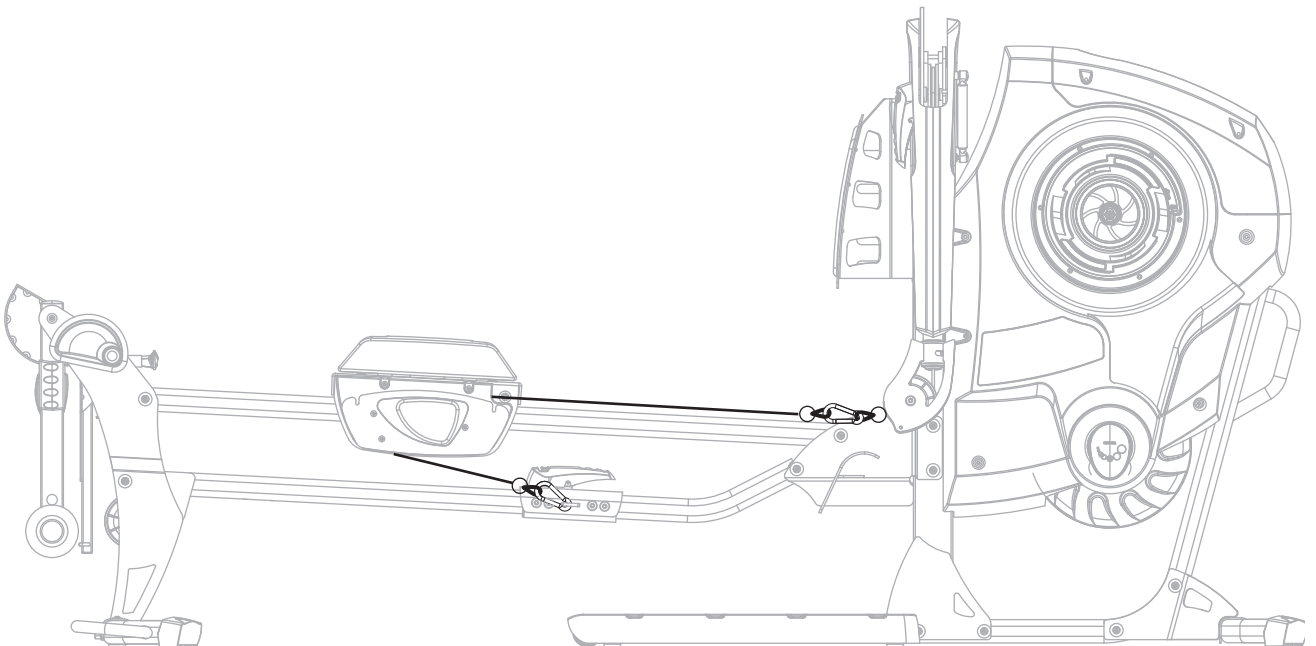
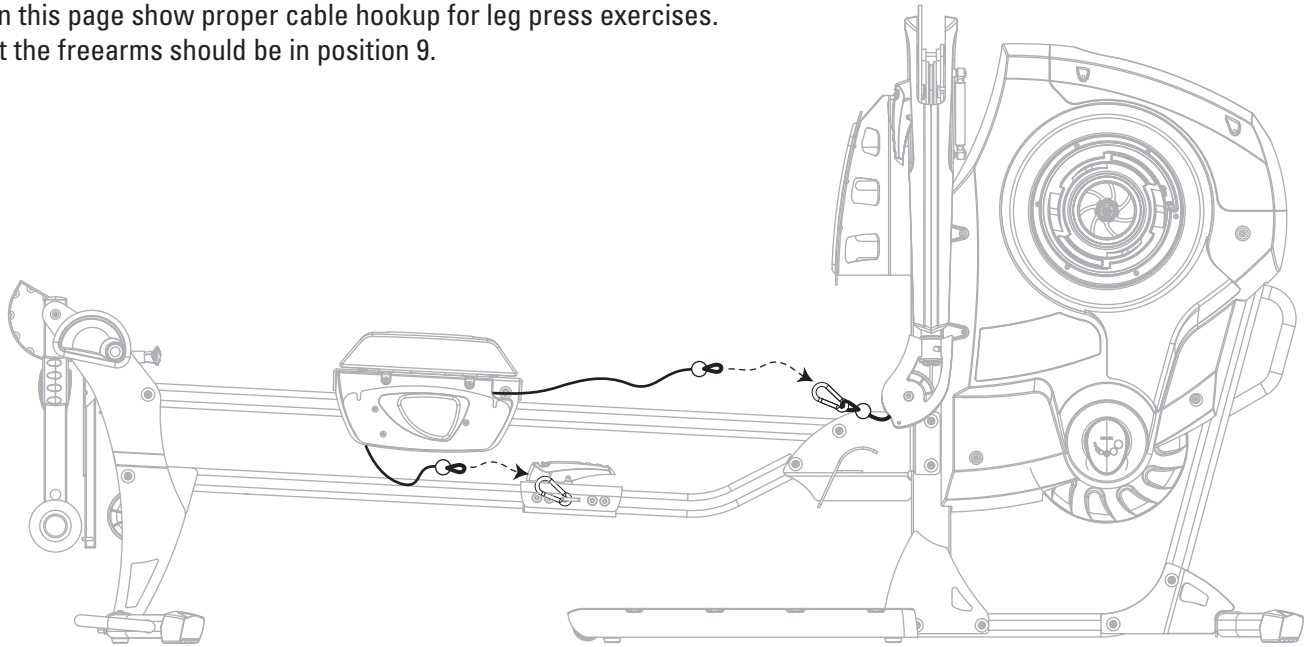

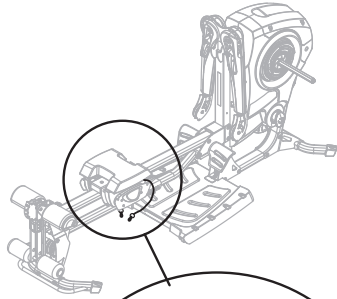

Side View

Step 1

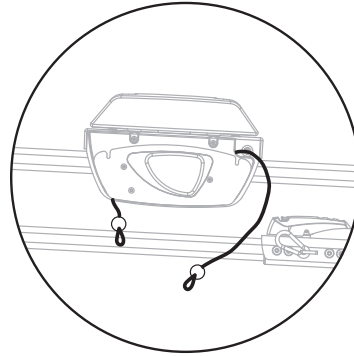
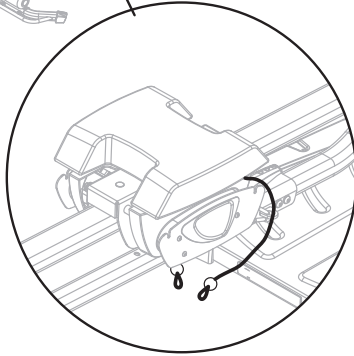

Step 1

Step 2

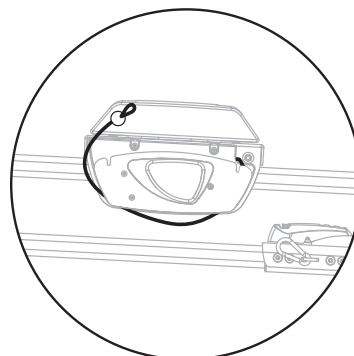
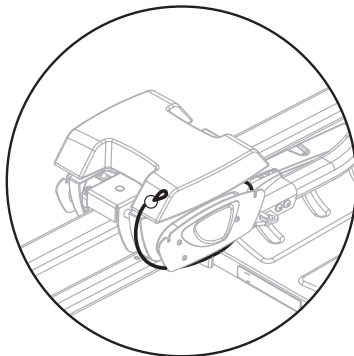

Step 2

Step 3

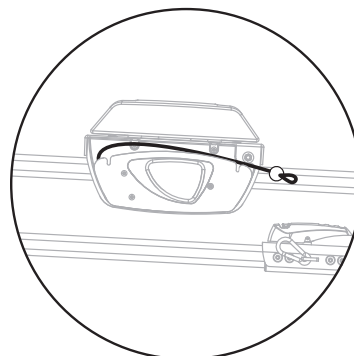
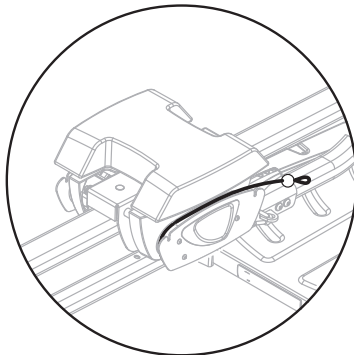

Step 3

Step 4

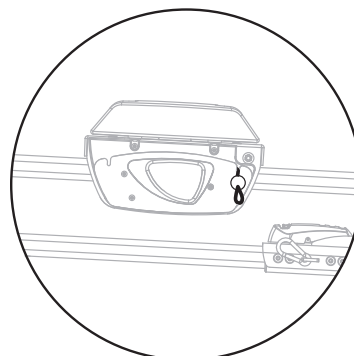
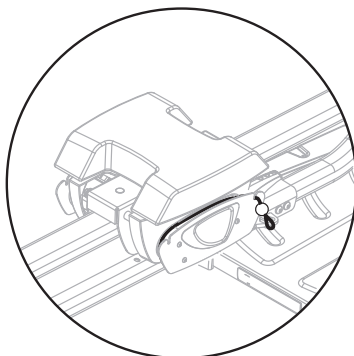

Step 4

# Storing Leg Extension Cables

---

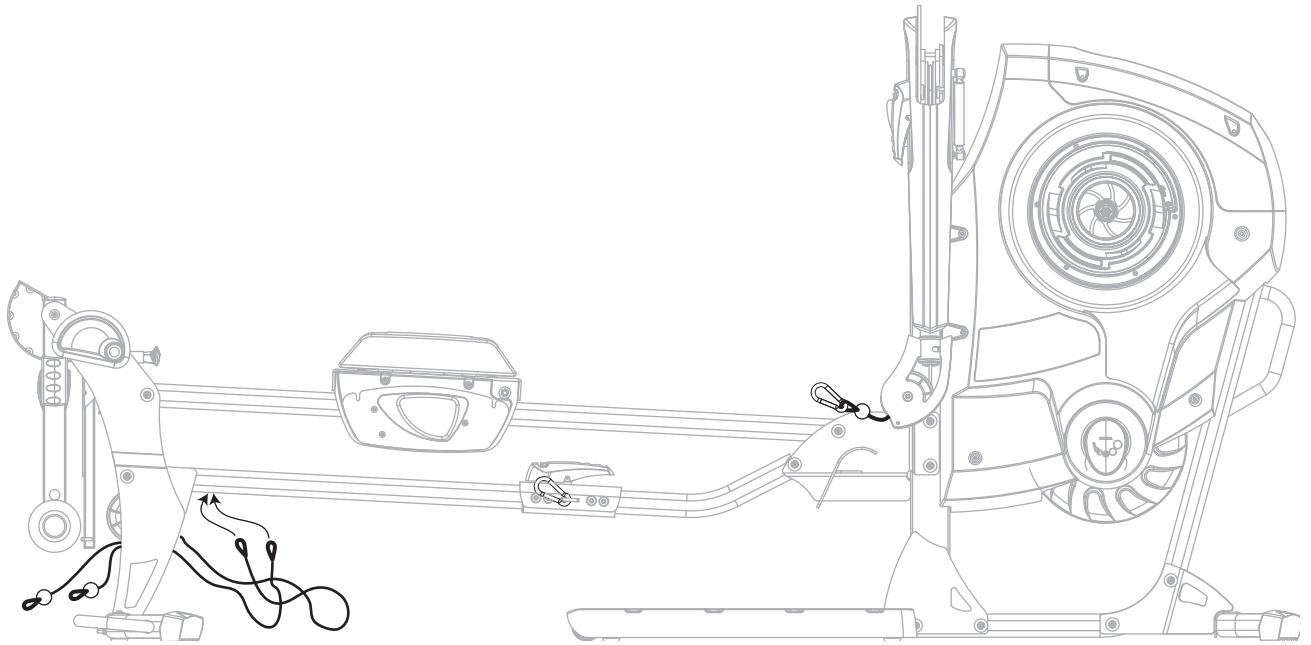



## Attaching Hand Grips and Foot Harnesses

Your Bowflex Revolution® home gym comes with a pair each of hand grips and foot harnesses.

### Hand Grips

You receive two hand grips with your Bowflex Revolution® home gym. Hand grips contain two D-rings on each grip, allowing for a shorter hand grip or longer hand grip, depending on the exercise.

For exercises that require a specific hand grip attachment, attaching to the D-ring closest to the handle will be referred to as using the “short hand grip”. Attachments to the D-ring furthest from the handle will be referred to as using the “long hand grip”.

Connect here for longer hand grip.

Connect here for shorter hand grip.

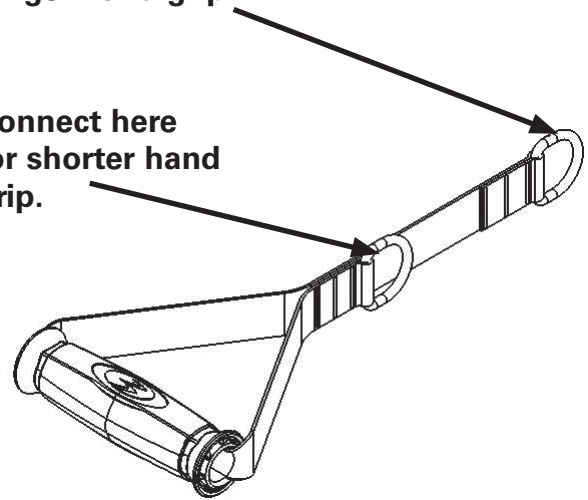

### Foot Harness

You additionally receive two foot harnesses. Foot harnesses are used for several types of leg exercises. The foot harnesses contain attachment rings on multiple sides.

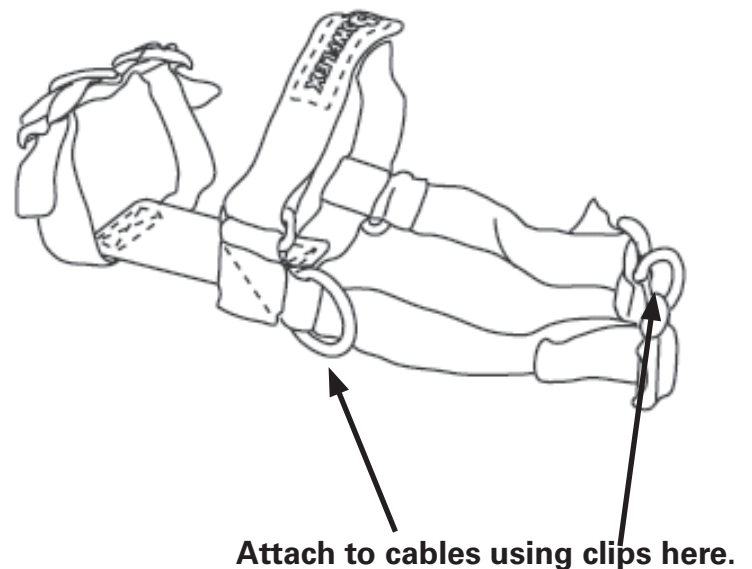

## Attaching Accessories, Benches, and Seats

Use the instructions on the following pages to attach each of the accessories/attachments.

### Leg Press Seatback

Use the leg press seatback when performing leg presses. Place the seatback in the opposite position to use as a back support for military presses and leg extensions. To attach this accessory, slide the leg press seatback arms into the seat roller assembly and tilt back to lock into place.

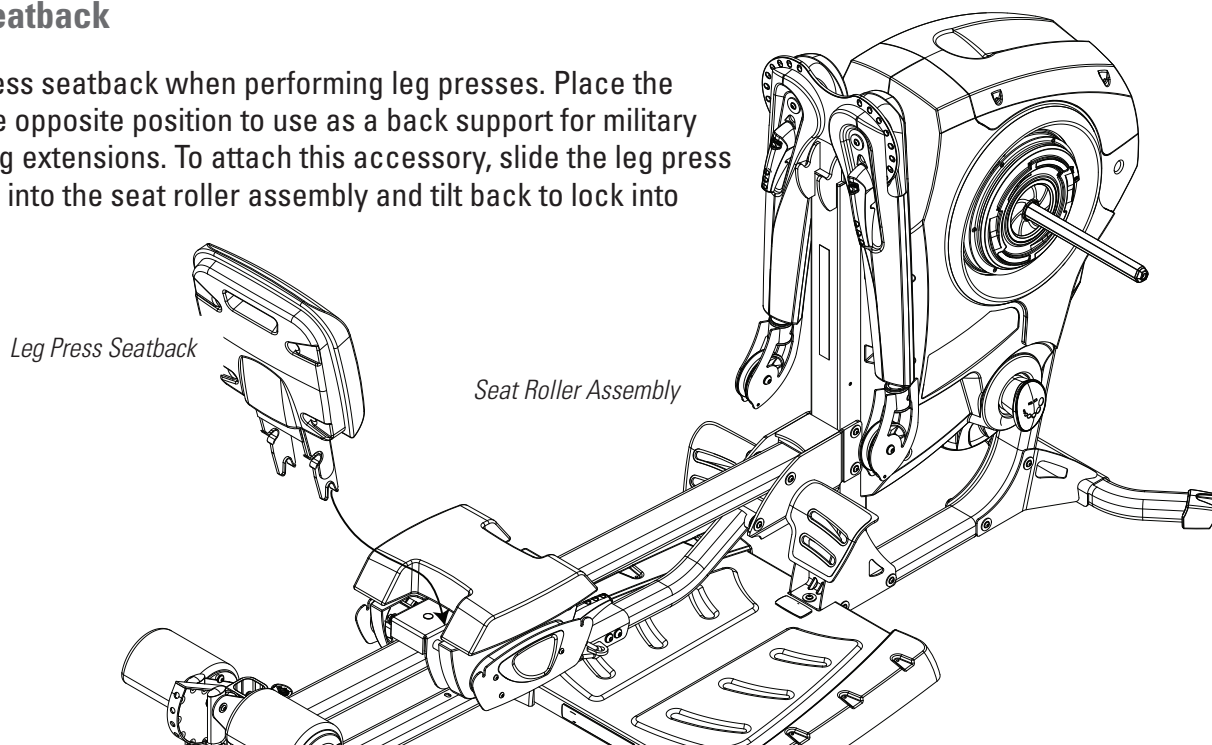

### Leg Press Plate

The leg press plate is used together with the leg press seatback when doing leg press exercises. To attach the leg press plate, place the cross bar on the leg press plate in the hooks on the main unit.

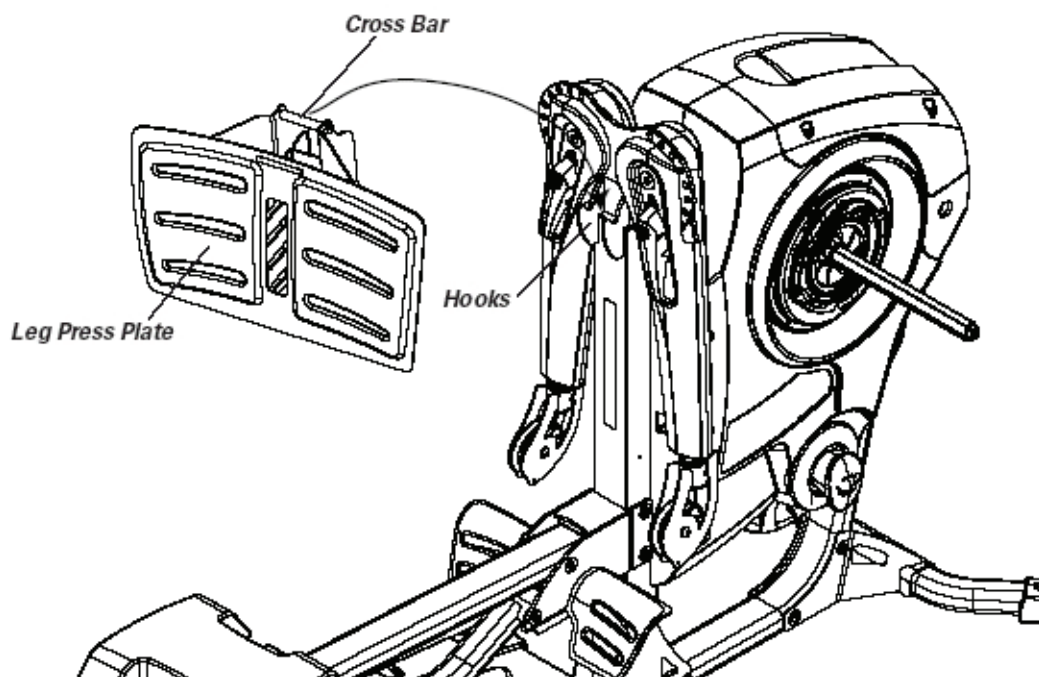

## Attaching Accessories, Benches, and Seats

### Preacher Curl

Pull out the pop-pin and slide the Preacher Curl Assembly into place. When the Preacher Curl is at the desired height, release the pop-pin to lock in place.

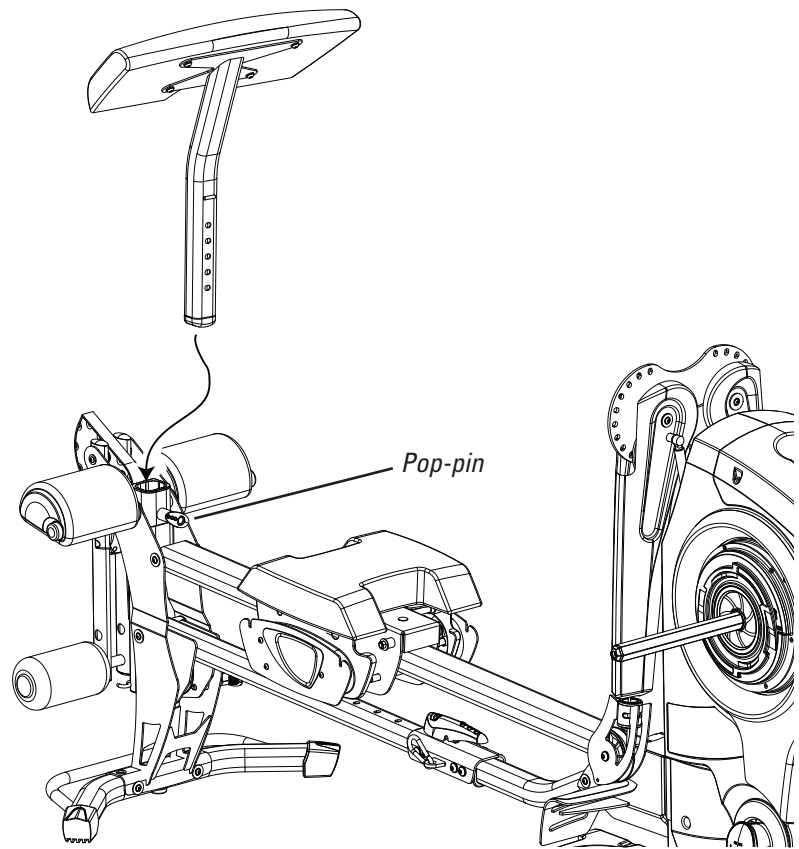

### Multi-Position Bench

The bench can be used in either of the following positions:

- Flat on the seat rail with the roller seat locked into the holes farthest from the engine on the rail, or
- At a 45-degree angle with the top of the bench hooked securely onto the hooks on the main frame assembly.

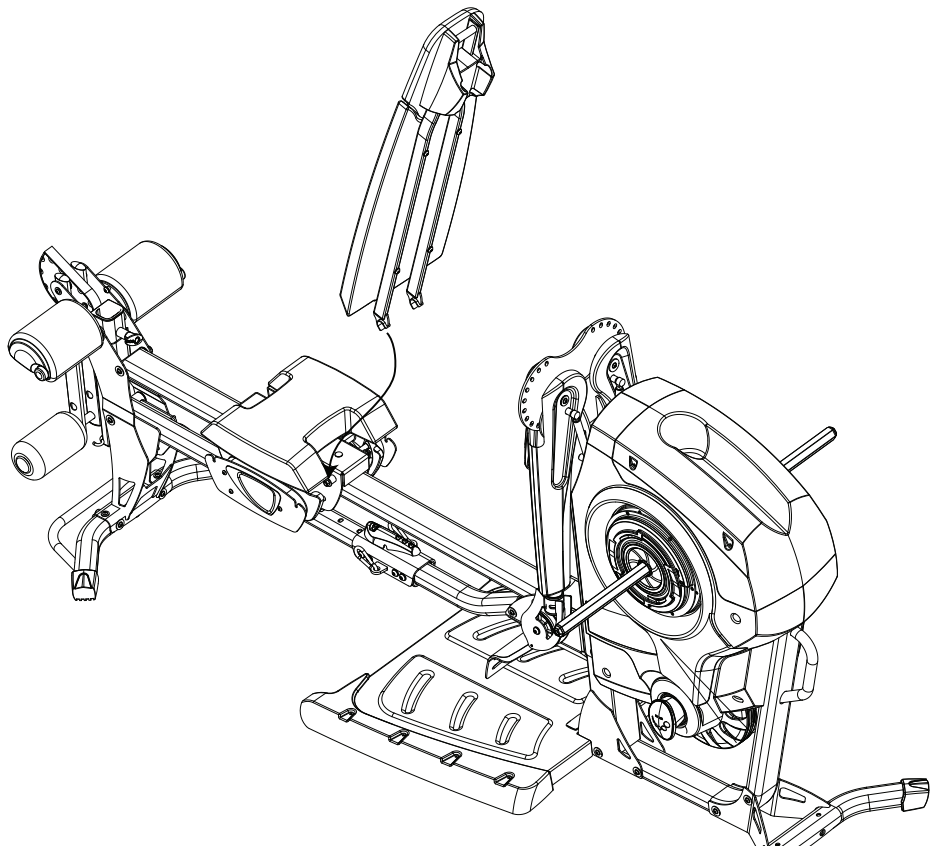

### WARNING

Do not use the bench in any position other than the two positions listed above. To do so may cause the seat to fall during use, posing potential injury.



## Companion Equipment

### Bowflex Revolution® Accessory Rack (ordered separately)

The Bowflex Revolution® home gym comes with many accessories and attachments to provide you with a wide variety of exercises. Between workouts, this specially designed accessory rack stores the gear that makes your home gym so versatile, so your workout area stays organized and ready for your next workout.

The accessory rack features:

Specially designed storage for many accessories including:

- Tall Seat Back
- Leg Press Plate
- Leg Press Seat Back
- Preacher Curl Assembly
- Resistance Packs
- Handgrips & Foot Harnesses

Heavy-duty steel construction for years of use

Stand Size: 2 ½' L x 2 ½' W x 3' H

Before



After



Check out the Bowflex Revolution® Accessory Rack and a wide selection of other great products available at [www.bowflex.com](http://www.bowflex.com)

## Defining Your Goals

---

Your body will do what you train it to do. That's why it's important to define your goals and focus on those goals. Here are some fitness components that will help you define your goals and choose your fitness program.

**Muscle Strength** is the maximum force you can exert against resistance at one time. Your muscle strength comes into play when you pick up a heavy bag of groceries or lift a small child. It is developed when a localized muscle is worked both positively (concentric) and negatively (eccentric) at a resistance great enough to perform only five to eight repetitions of the exercise before the muscle fails. Each set of repetitions is followed by a rest interval that typically runs three times longer than the set. Later, between exercise sessions, the muscle overcompensates for the stress and usually increases in both strength and size.

**Muscle Endurance** is the ability to perform repeated contractions. It comes into play when you cross-country ski or work on your feet all day. Endurance training addresses the slow twitch, endurance muscle fibers, which depend on oxygen for energy. To develop muscle endurance, use low resistance and high repetitions— about 15-20 repetitions in each set, three sets to each exercise, working the muscle only to fatigue.

**Muscle Power** is the combination of strength and speed of the muscular contraction. This is often misinterpreted as:

- a) Being directly associated with certain skill or sport; and/or
- b) Meaning that you must move fast.

Load is actually a more important factor than speed when attempting to improve power. When training to achieve muscular power, pick a resistance that fatigues you in the 3-5 repetition range. When performing these reps, it is more important to think of contracting the muscles faster rather than attempting to move faster. Performing sport simulation exercises usually results in a deterioration of the motor pattern or skill. The biomechanically sound method of improving power in your sport is to train for power using the correct joint movements, as described in this manual. Then practice the skill associated with your sport, learning to apply this newly achieved power.

**Body Composition** is the ratio of fat weight (fat) to lean weight (muscles, bones and tissue). As you age, the ratio shifts. The fat weight increases and the lean weight decreases. Training for muscle strength will generally increase muscle size and aerobic conditioning will help burn extra calories. Performing these two forms of exercise, either at different times or together, will create the greatest changes in body fat weight.

**Balanced Strength** and alignment is the result of equal strength developed in all parts of the body. It comes into play in your standing and sitting posture, and in your ability to perform just about any activity safely and effectively. Muscle weakness of the back will round the shoulders; weakness of the abdominals can cause lower back pain. You want a balance of muscle strength in front and back. In addition, you need a balance of strength between your middle, lower, and upper body.

**Flexibility** is the ability of a muscle or group of muscles to move the joint through a full range of motion. Flexibility comes into play when you execute an overhand serve or stretch for the top shelf in the kitchen. It is a cooperative movement of opposite muscle groups. When a muscle contracts, its opposite muscle group must relax for the action to occur. Increased flexibility means an increased range of motion, made possible by this simultaneous contracting and relaxing. Good flexibility is important in protecting the body from injury and can be achieved through the balanced strength training programs included in this manual.

**Cardiovascular Endurance** is the ability of the heart and lungs to supply oxygen and nutrients to exercising muscles over an extended period of time. It comes into play when you jog a mile or ride a bike. It is a critical component of overall fitness and health. Any exercise program must be supplemented with cardiovascular training, such as rowing on the Bowflex Revolution™.

# Defining Your Goals

## Reaching Your Goals

To reach your goals you must follow a consistent, well designed program that provides balanced development to all parts of the body and includes both aerobic and strength exercise. Only then will you meet your goals safely and efficiently.

The workout routines found in this manual are professionally designed and written to target specific fitness goals. Should you not find one specific program to your liking, you can design your own, based on sound information and the principles found in this manual.

## Designing Your Own Program

You may want to design your own personal program specifically geared to your goals and lifestyle. Designing a program is easy, as long as you follow these guidelines.

**Understand fitness and its components:** Improperly designed programs can be dangerous. Take some time to review this manual as well as other fitness guides.

**Know your current fitness level:** Before you start any fitness program you should consult a physician who will help you determine your current abilities.

**Identify your goals:** Goals are critical to choosing and designing an exercise program that fits and enhances your lifestyle, but so is strategy. It's important not to rush the process and try to accomplish too much too soon. That will lead to setbacks and discouragement. Instead, set a series of smaller achievable goals.

**Select complementary exercises:** Be sure to pair exercises that address compound joint movements and single joint movements. In addition, select exercises that address complementary muscle groups.

**Put first things first:** During each session, first work those muscle groups that need the most training.

**Remember your cardiovascular component:** Any fitness program must contain a cardiovascular fitness component to be complete. So complement your resistance training with aerobic exercise such as walking, running, bicycling or rowing on the Bowflex Revolution®.

**Training variables:** When designing your own program there are several variables that, when mixed properly, will equal the right fitness formula for you. In order to find the best formula, you must experiment with several combinations of variables. The variables are as follows:

- **Training Frequency:** The number of times you train per week. We recommend daily activity but not daily training of the same muscle group.
- **Training Intensity:** The amount of resistance and effort level of the individual used during your repetition.
- **Training Volume:** The number of repetitions and sets performed.
- **Rest intervals:** The time you rest between sets and the time you rest between workouts.

Once you've established a base of fitness, follow these basic principles:

- **Isolate muscle groups:** Focus work on specific muscle groups.
- **Progressive Loading:** The gradual systematic increase of repetitions, resistance and exercise period.

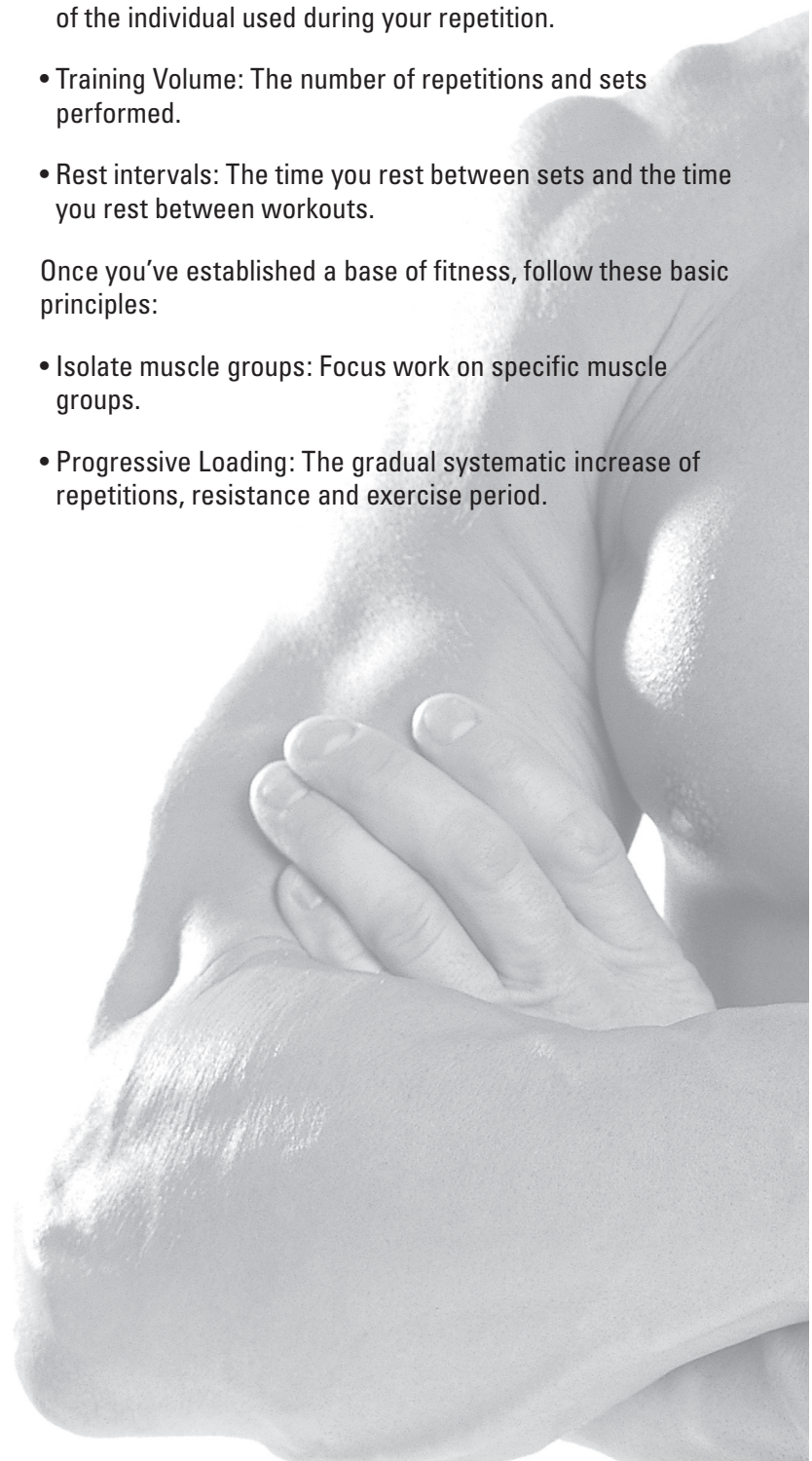

## Exercising Properly

### Working Out

A workout begins in your mind's eye. With concentration and visualization you can approach your workout with a positive, constructive attitude. A good pre-workout mental routine is to sit and relax, so you can focus on what you are about to do and think about achieving your end goal.

### Warming Up

We recommend that you warm up by rowing on the Bowflex Revolution® home gym.

### Aerobic Rowing Position:

Aerobic rowing on the Bowflex Revolution® home gym is done using the hand grips connected to the pulley cables

- Remove bench, unlock the seat by pulling the pop pin and locking it in the out position by rotating the pop pin. This allows the seat to move freely along the rail without locking into any one position.
- Sit on the seat facing the SpiraFlex® resistance packs.
- Move the arms into position 4 or 5.
- Position the arches of your feet on the footrest of the machine, knees bent comfortably.
- Grasp the hand grips and sit up straight with your spine in good alignment.



### Motion:

- Initiate the movement by extending the knees while simultaneously bending the arms and pinching the shoulder blades together.
- With the arms passing by the sides of your trunk, the handles should be near your torso as the knees near extension.

### Key Points:

- Do not lose spinal alignment — keep your chest lifted.
- If you bend forward during the return, bend at the hips, not the waist.

### Breathing

The most important part of breathing during exercise is, quite simply, that you do it. Breathing in or out during the actual performance is not dependent upon the direction of air flow relative to exertion. It is, in fact, a mechanical process that changes the position of your spine as your rib cage moves. Here are some tips for breathing:

- 1) Be cautious when you are concentrating or exerting effort. This is when you will probably hold your breath. **DO NOT** hold your breath. Do not exaggerate breathing. Depth of inhalation and exhalation should be natural for the situation.
- 2) Allow breathing to occur naturally. Don't force it.

### Performing Your Routine

The workout portion of your fitness routine is the series of exercises devoted to your particular goals. Remember, make sure to have fun!

### Cool Down

An essential part of the exercise routine is the cool down. Gradually reduce the level of exercise intensity so that blood does not accumulate in one muscle group, but continues to circulate at a decreasing rate. We recommend the rowing exercise for the cool down. Remember to gradually move yourself into a relaxed state.



# The Workouts

## 20 Minute Better Body Workout

**Frequency: 3 Days Per Week (M-W-F) Time: About 20 Minutes**

Start by performing one set of each exercise. Warm up with a light resistance exercise that you can perform easily for 5 -10 reps without fatiguing. Focus on practicing and learning your technique before increasing the resistance. Then move to a more challenging resistance you can perform for no less than 10 reps and no more than 15 reps without your form deteriorating. As you become stronger, you can advance to two sets for each exercise. Complete all sets of each exercise before moving on to the next. Rest 30 to 45 seconds between sets. Move slowly on each rep. Use a pace that will allow you to stop the movement instantly at any point in the rep. Count three seconds up and three seconds down and work to fatigue during each set.

Body Part	Exercise	Sets	Reps
Back	Seated Lat Row	1-2	10-15
Shoulders	Rear Delt Row	1-2	10-15
Arms	Lying Triceps Extension	1-2	10-15
	Standing Biceps Curl	1-2	10-15
Trunk	Low Back Extension	1-2	10-15
	Resisted Abdominal Crunch	1-2	10-15
Chest	Bench Press	1-2	10-15
Legs	Leg Extension	1-2	10-15
	Leg Curl	1-2	10-15

## Advanced General Conditioning

**Frequency: 4 Days Per Week (M-T-TH-F) Time: About 35-45 Minutes**

When you are proficient in performing the exercise techniques of the above routine and are no longer realizing results, or if you become bored, it is time to change your program. You can increase your training with this "split system" routine that works opposing muscle groups on different days. To do this, you'll increase your resistance when you can perform 12 reps perfectly, and you'll increase your volume by performing more sets and more exercises. Move slowly on each rep. Use a pace that will allow you to stop the movement instantly at any point in the rep. Count three seconds up and three seconds down and work to fatigue during each set.

Day 1 & 3

Body Part	Exercise	Sets	Reps
Chest	Standing Chest Press	1-3	10-12
Shoulders	Standing Shoulder Press	1-3	10-12
Arms	Rope Pushdown	1-3	10-12
	Standing French Press	1-3	10-12
Legs	Leg Press	1-3	10-12
	Seated Calf Raise	1-3	10-12

Day 2 & 4

Body Part	Exercise	Sets	Reps
Back	Standing Lat Row	1-3	10-12
	Stiff Arm Pulldown	1-3	10-12
Shoulders	Standing Cable Cross Rear Deltoid Row	1-3	10-12
Arms	Standing Biceps Curl	1-3	10-12
	Resisted Dip	1-3	10-12
Trunk	Trunk Rotation	1-3	10-12
	Standing Low Back Extension	1-3	10-12
	Seated Resisted Abdominal Crunch	1-3	10-12

# The Workouts

---

## 20 Minute Upper/Lower Body

**Frequency: 4 Days Per Week (M-T-TH-F)      Time: About 20 Minutes**

This program provides you with a quick and effective workout that combines muscle conditioning with some cardiovascular benefits. Do this routine when you are limited in time or just want a variation to your normal routine. Perform this program training 2 days, resting 1 to 2. Perform all exercises to near failure, stopping at the point that your technique starts to deteriorate. Rest only 20-30 seconds between sets. As you get stronger, increase the number of sets you perform. Move slowly on each rep. Use a pace that will allow you to stop the movement instantly at any point in the rep. Count three seconds up and three seconds down and work to fatigue during each set.

### DAY 1 & 3

Body Part	Exercise	Sets	Reps
Chest	Bench Press	1-3	12-15
Back	Seated Lat Row	1-3	12-15
Shoulders	Seated Shoulder Press	1-3	12-15
Arms	French Press	1-3	12-15
	Standing Biceps Curl	1-3	12-15

### DAY 2 & 4

Body Part	Exercise	Sets	Reps
Legs	Leg Extension	1-3	12-15
	Leg Curl	1-3	12-15
	Leg Press	1-3	12-15
	Seated Calf Raise	1-3	12-15
Trunk	Seated Low Back Extension	1-3	10-12
	Seated Resisted Abdominal Crunch	1-3	10-12

# The Workouts

## Body Building

**Frequency: 3 Days On, 1 Day Off**     **Time: About 45-60 Minutes**

Body building requires focused concentration and dedication to training, as well as proper eating habits. Train each muscle group to failure before moving on to the next exercise. Do not neglect any muscle group. If needed, include an aerobic activity to increase your caloric expenditure and help to reduce your body fat levels to achieve a defined muscular look. Rest 30-60 seconds between each set and exercise. Focus on proper form. Tighten the muscle before you move, squeeze the muscle as you move, cramp the muscle at the point of full contraction, and resist the movement as you lower the weight. Move slowly on each rep. Use a pace that will allow you to stop the movement instantly at any point in the rep. Count three seconds up and three seconds down and work to fatigue during each set.

### DAY 1

Body Part	Exercise	Sets	Reps
Chest	Bench Press	2-4	8-12
	Decline Chest Fly	2-4	8-12
Shoulders	Seated Shoulder Press	2-4	8-12
	Rear Deltoid Row	2-4	8-12
	Standing Lateral Raise	2-4	8-12
	Shoulder Shrug	2-4	8-12

### DAY 2

Body Part	Exercise	Sets	Reps
Back	Seated Lat Rows	2-4	8-12
	Narrow Pulldown w/ Hand Grips	2-4	8-12
Arms	Standing Biceps Curl	2-4	8-12
	Standing Hammer Grip Curls	2-4	8-12
	Seated Triceps Extension	2-4	8-12
	Seated French Press	2-4	8-12

### DAY 3

Body Part	Exercise	Sets	Reps
Legs	Standing Hip Extension	2-4	8-12
	Leg Extension	2-4	8-12
	Leg Curl	1-3	8-12
	Leg Press	2-4	8-12
	Seated Calf Raise	2-4	12-15
Trunk	Seated Low Back Extension	2-4	8-12
	Seated Resisted Abdominal Crunch	2-4	8-12
	Seated Resisted Oblique Crunch	2-4	8-12
Aerobic	Aerobic Rowing	Progress up to 15-25 minutes	

# The Workouts

## Circuit Training – Anaerobic/Cardiovascular

**Frequency: 2-3 Times Per Week      Time: About 20-45 Minutes**

Circuit training is a great way to achieve the benefits of strength training and cardiovascular training in one quick, challenging routine. The idea is to move quickly from exercise to exercise, taking only as much rest between sets as it takes to set up the next exercise (less than 20 seconds). One circuit equals one set of each exercise. Initially, start with completing one round of Circuit 1. Then add an additional round of the same circuit. Once you reach three rounds of Circuit 1, add one round of Circuit 2. Add additional rounds of Circuit 2 as your fitness level increases. Repeat process with Circuit 3. Do not let your heart rate exceed 220 minus your age. Perform each rep of each exercise slowly and with perfect technique. Count three seconds up and three seconds down. Warm-up with 5-15 minutes of rowing or some other aerobic exercise before starting your circuits.

### Circuit 1

Body Part	Exercise	Reps
Chest	Standing Chest Press	8-12
Legs	Standing Leg Kickback	8-12
Back	Standing Lat Row Alternating	8-12
Legs	Standing Hip Abduction	8-12
Trunk	Standing Trunk Rotation	8-12

### Circuit 2

Body Part	Exercise	Reps
Shoulders	Seated Shoulder Press	8-12
Back	Lying Lat fly	8-12
Trunk	Seated Low Back Extension	8-12
Arms	Standing Biceps Curl	8-12
Legs	Leg Press	8-12

### Circuit 3

Body Part	Exercise	Reps
Shoulders	Standing Rear Deltoid Row	8-12
Arms	Rope Pushdown	8-12
Trunk	Standing Resisted Oblique Crunch	8-12
Legs	Leg Extension	8-12
	Leg Curl	8-12

# The Workouts

## True Aerobic Circuit Training

**Frequency: 2-3 Times Per Week**      **Time: About 20-60 Minutes**

Circuit training is a great way to achieve the benefits of strength training and cardiovascular training in one quick, challenging routine. By returning to the aerobic rowing exercise between each set you are increasing your aerobic capacity, endurance and burning fat as energy. The idea is to move quickly from exercise to exercise, taking only as much rest between sets as it takes to set up the next exercise (less than 20 seconds). One circuit equals one set of each exercise. Initially, start with completing one round of Circuit 1. Then add an additional round of the same circuit. Once you reach three rounds of Circuit 1, add one round of Circuit 2. Add additional rounds of Circuit 2 as your fitness level increases. Do not let your heart rate exceed 220 minus your age. Perform each rep of each exercise slowly and with perfect technique. Count three seconds up and three seconds down.

Warm-up with 5-15 minutes of rowing or some other aerobic exercise before starting your circuits.

### Circuit 1

Body Part	Exercise	Reps
Chest	Standing Chest Press	8-12
Aerobic Rowing	30 - 60 Seconds	
Legs	Standing Hip Extension	8-12
Aerobic Rowing	30 - 60 Seconds	
Back	Seated Lat Row	8-12
Aerobic Rowing	30 - 60 Seconds	
Legs	Standing Leg Kickback	8-12
Aerobic Rowing	30 - 60 Seconds	
Trunk	Standing Oblique Crunch	8-12
Aerobic Rowing	30 - 60 Seconds	

### Circuit 2

Body Part	Exercise	Reps
Shoulders	Shoulder Shrug	8-12
Aerobic Rowing	30 - 60 Seconds	
Legs	Standing Hip Flexion w/Knee Flexion	8-12
Aerobic Rowing	30 - 60 Seconds	
Back	Stiff Arm Pulldown	8-12
Aerobic Rowing	30 - 60 Seconds	
Trunk	Standing Low Back Extension	8-12
Aerobic Rowing	30 - 60 Seconds	
Arms	Standing Biceps Curl	8-12

# The Workouts

## Strength Training

**Frequency: 3 Days Per Week (M-W-F) Time: About 45-60 Minutes**

This program is designed to emphasize overall strength development. This is an advanced routine to be used only after you have progressed from the advanced general conditioning routine and only after you have perfected your exercise techniques. Work each set to near exhaustion. If you can perform more than 5 to 8 reps, you should increase your resistance 5 pounds and decrease your reps to 5. Rest 60 - 120 seconds between each set and exercise. Focus on proper form. Tighten the muscle before you move, squeeze the muscle as you move, cramp the muscle at the point of full contraction, and resist the movement as you lower the weight. Move slowly on each rep. Use a pace that will allow you to stop the movement instantly at any point in the rep. Count two seconds up and four seconds down and work to fatigue during each set.

Day 1

Body Part	Exercise	Sets	Reps
Chest	Bench Press	2-4	5-8
	Decline Chest Press	2-4	5-8
Shoulders	Seated Shoulder Press	2-4	5-8
	Seated Lateral Raise	2-4	5-8
	Rear Deltoid Row	2-4	5-8
	Shoulder Shrug	2-4	5-8

Day 2

Body Part	Exercise	Sets	Reps
Back	Seated Lat Row	2-4	5-8
	Narrow Lat Pulldown	2-4	5-8
Arms	Standing Biceps Curl	2-4	5-8
	Standing Biceps Curl- Shoulder Ext	2-4	5-8
	Triceps Kickback	2-4	5-8
	Rope Pushdown	2-4	5-8

Day 3

Body Part	Exercise	Sets	Reps
Legs	Leg Press	2-4	5-8
	Seated Calf Raise	2-4	5-8
	Leg Extension	2-4	5-8
	Prone Leg Curl	2-4	5-8
Trunk	Seated Low Back Extension	2-4	8-12
	Resisted Abdominal Crunch	2-4	5-8

# Exercises

---

## A Revolutionary Way to Exercise

The Bowflex Revolution® home gym provides an unparalleled number of exercises, with more than 90 exercises and over 400 total variations. You can switch quickly between hundreds of exercises with less setup time than most gym machines. That means a shorter workout while maintaining a higher, calorie-burning heart rate.

This manual and the included poster provide information on a large number of these exercises, but feel free to vary the exercises to meet your needs. Using the adjustable freearms, you can set the arms at 8 for one exercise, and exercise an entirely different set of muscles by simply moving the freearms to 6 or 7 and doing the same exercise.

Changing exercises is simple. The freearms rotate between positions 0 and 9, with 0 being straight up and 9 being straight down. That means you have ten arm positions to work out with, each one providing a slightly different variation of each exercise. Switching cables between exercises is simple with snap-hook attachments.



## Chest Exercises

### Bench Press — Shoulder Horizontal Adduction (and elbow extension)

#### Muscles worked:

Pectoralis Major; Deltoids; Triceps

#### Bench Position:

45° incline

#### Accessory:

Long Hand Grips

#### Adjustable Arm Position:

7 or 8

#### Success Tips

- Maintain a 90° angle between upper arms and torso throughout motion.
- Keep chest muscles tightened. Limit and control your range of motion.
- Keep knees bent, feet on floor, head back against bench.
- Do not let your elbows travel behind your shoulders.
- Keep shoulder blades pinched together and maintain good spinal alignment.



#### START

- Curl grips up into position.
- Keep elbows back and out to your sides.

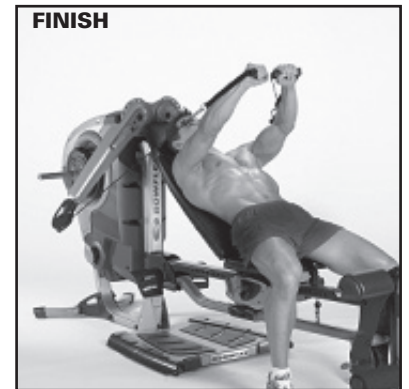

#### FINISH

- Press straight out a way from chest.
- Return to Start position slowly.

### Chest Fly — Shoulder Horizontal Adduction (elbow stabilized)

#### Muscles worked:

Pectoralis Major; Anterior Deltoid

#### Bench Position:

45° incline

#### Accessory:

Long Hand Grips

#### Adjustable Arm Position:

7 or 8

#### Success Tips

- Maintain a 60-90° angle between upper arms and torso during exercise.
- Keep chest muscles tightened. Limit and control your range of motion.
- Keep knees bent, feet on floor, head back against bench.
- Do not let your elbows travel behind your shoulders.
- To improve your pectoralis involvement, keep your shoulder blades pinched together throughout upward and downward movements.



#### START

- Grasp Hand Grips in both hands.
- Open your arms into a wide, elbow bent position. Keeping elbows and forearms below chest level, palms forward.
- Raise chest, pinch shoulder blades together, and maintain a slight, comfortable arch in your lower back.



#### FINISH

- Slowly press your arms forward and upward, straightening arms and moving your hands together.
- Slowly return to Start position



## Chest Exercises

### Resisted Punch — Shoulder Flexion, Elbow Extension, Scapular Protraction

#### Muscles worked:

Anterior Deltoid; Triceps; Pectoralis Major

#### Bench Position:

Flat Bench Back

#### Accessory:

Long Hand Grips

#### Adjustable Arm Position:

8 (up/center)

#### Success Tips

- Maintain an upright, erect posture as your trunk rotates with the punch.
- Keep knees bent and feet on floor.
- Maintain good spinal alignment.

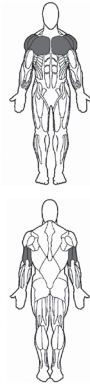

#### START

- Sit on the bench facing away from the engine.
- Reach behind your body and grasp the Hand Grips with an overhand grip, as shown above.
- Bend your elbows until your hands are level with your waist.



#### FINISH

- Using moderate speed, rotate your trunk and press your arm(s) forward to full extension, allowing shoulder blade to move forward at the end of the punch.
- Slowly return to the Start position. Do not relax the tension in your arm.
- You may vary this exercise by using bilateral movement with both arms or punching upward or downward.

### Lying Cable Crossover — Shoulder Adduction (elbow stabilized)

#### Muscles worked:

Pectoralis Major

#### Bench Position:

Flat

#### Accessory:

Long Hand Grips

#### Adjustable Arm Position:

6 or 7

#### Success Tips

- Keep chest lifted throughout exercise.
- Keep knees bent, feet on floor, head back against bench.

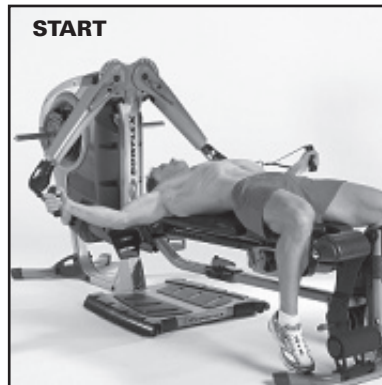

#### START

- Lie flat on your back, head toward the engine. Position yourself far enough down the Bench to grasp the Hand Grips over your head with arms straight out to the side.
- Grasp the Hand Grips, palms facing down toward your feet.
- Tighten your abdominals to stabilize your spine. Maintain a slight, comfortable arch in your lower back.



#### FINISH

- Keep your elbows straight, while moving your arms in an arc upward and across your torso toward the opposite thigh.
- Control the return to the Start position by slowly moving your arms back to shoulder level, releasing the shoulder blades and keeping arms straight.

## Chest Exercises

### Decline Chest Fly

#### Muscles worked:

Pectoralis Major; Anterior Deltoid

#### Bench Position:

45° incline

#### Accessory:

Long Hand Grips

#### Adjustable Arm Position:

5, 6, or 7

#### Success Tips

- Maintain a 90° angle between your upper arms and your torso throughout the exercise.
- Limit and control the range of motion so that your elbows do not travel behind your shoulders.
- Keep your shoulder blades pinched together and maintain good spinal alignment.



START



FINISH

#### START

- Sit in the 45° position, reach straight behind your body, grasp the Hand Grips, and slightly bend your elbows with your palms facing forward.
- Keeping knees bent and feet flat on the floor, lay your head back against the bench.
- Start with your upper arms out to the sides, level with your shoulders.

#### FINISH

- Slowly move your arms parallel to the floor and inward, maintaining the elbow in a slightly bent position throughout the movement.
- Slowly return to the Start position keeping your chest muscles tightened during the entire motion.

### Incline Chest Fly

#### Muscles worked:

Pectoralis Major; Anterior Deltoid

#### Bench Position:

45° incline

#### Accessory:

Long Hand Grips

#### Adjustable Arm Position:

8, 9

#### Success Tips

- Maintain a 90° angle between your upper arms and your torso throughout the exercise.
- Limit and control the range of motion so that your elbows do not travel behind your shoulders.
- Keep your shoulder blades pinched together and maintain good spinal alignment.



START



FINISH

#### START

- Reach straight behind your body, grasp the Hand Grips, and slightly bend your elbows with your palms facing forward.
- Keeping knees bent and feet flat on the floor, lay your head back against the bench.
- Start with your upper arms out to the sides, level with your shoulders.

#### FINISH

- Slowly move your arms up and inward, maintaining the elbow in a slightly bent position throughout the movement.
- Slowly return to the Start position keeping your chest muscles tightened during the entire motion.

## Chest Exercises

### Standing Chest Press — Shoulder Horizontal Adduction (and elbow extension)

#### Muscles worked:

Pectoralis Major; Deltoids; Triceps. Also ankles, knees, hips and core in stabilization.

#### Bench Position:

Removed

#### Accessory:

Long Hand Grips

#### Adjustable Arm Position:

3,4 or 5



#### Success Tips

- Stabilize body from your feet all the way up through your trunk.
- Maintain a 90° angle between upper arms and torso throughout the motion.
- Keep chest muscles tight, limit and control your range of motion.
- Keep knees slightly bent, feet flat on the floor and in a staggered step for stability.
- Keep shoulder blades pinched, chest lifted and a slight curve in the lower back.

#### START

- Grasp the Hand Grips so the cables are in line close to the front of your forearms.
- Stand with one foot forward and one foot back for added stability.
- Start with elbows bent to 90° and slightly behind or equal to the shoulders.

#### FINISH

- Press straight out away from your chest, bringing the handles together in front of you.
- Slowly return to the Start position, keeping tension on the chest throughout the motion.

### Standing Chest Press w/ Alternating Shoulder Movement

#### Muscles worked:

Pectoralis Major; Deltoids; Triceps. Also ankles, knees, hips and core in stabilization.

#### Bench Position:

Removed

#### Accessory:

Long Hand Grips

#### Adjustable Arm Position:

3,4 or 5



#### Success Tips

- Stabilize body from your feet all the way up through your trunk.
- Maintain a 90° angle between upper arms and torso throughout the motion.
- Keep chest muscles tight, limit and control your range of motion.
- Keep knees slightly bent, feet flat on the floor and in a staggered step for stability.
- Keep shoulder blades pinched, chest lifted and a slight curve in the lower back.
- Do not allow your trunk to rotate during the motion.

#### START

- Grasp the Hand Grips so the cables are in line close to the front of your forearms.
- Stand with one foot forward and one foot back for added stability.
- Start with one elbow bent to 90° and slightly behind or equal to the shoulders, and the other arm straight out in front of you.

#### FINISH

- Press straight out away from your chest with one arm, as the other arm moves out and back. This is an alternating motion, so your arms will move in the opposite direction during the set.
- Slowly return each arm to the Start position, keeping tension on the chest throughout the motion.

## Chest Exercises

### Incline Chest Press — Shoulder Horizontal Adduction (and elbow extension)

#### Muscles worked:

Pectoralis Major; Deltoids; Triceps.

#### Bench Position:

45°

#### Accessory:

Long Hand Grips

#### Adjustable Arm Position:

7 or 8

#### Success Tips

- Maintain a 90° angle between upper arms and torso at the start of the press, and slightly higher than 90° at the finish.
- Keep chest muscles tight, limit and control your range of motion.
- Keep knees slightly bent, feet flat on the floor.
- Keep shoulder blades pinched, chest lifted and a slight curve in the lower back.



#### START



#### START

- Grasp the Hand Grips so the cables travel above the forearms.
- Keep your forearms in line with the cables at all times.
- Start with elbows bent to 90° and slightly behind or even with the shoulders.

#### FINISH



#### FINISH

- Press slightly upward, away from your chest, bringing the handles together in front of you at about 10° above your shoulders.
- Slowly return to the Start position, keeping tension on the chest throughout the motion.

### Standing Incline Chest Press — Shoulder Horizontal Adduction (and elbow extension)

#### Muscles worked:

Pectoralis Major; Deltoids; Triceps. Also ankles, knees, hips and core in stabilization.

#### Bench Position:

Removed

#### Accessory:

Long Hand Grips

#### Adjustable Arm Position:

4 or 5

#### Success Tips

- Stabilize body from your feet all the way up through your trunk.
- Maintain a 90° angle between upper arms and torso at the start of the press, and slightly higher than 90° at the finish.
- Keep chest muscles tight, limit and control your range of motion.
- Keep knees slightly bent, feet flat on the floor and in a staggered step for stability.
- Keep shoulder blades pinched, chest lifted and a slight curve in the lower back.



#### START



#### START

- Stand with one foot forward and one foot back for added stability.
- Start with elbows bent to 90° and slightly behind or even with the shoulders.

#### FINISH



#### FINISH

- Press slightly upward, away from your chest, bringing the handles together in front of you at about 10° above your shoulders.
- Slowly return to the Start position, keeping tension on the chest throughout the motion.

## Chest Exercises

### Standing Incline Chest Press w/ Alternating Motion – Shoulder Horizontal Adduction

#### Muscles worked:

Pectoralis Major; Deltoids; Triceps. Also ankles, knees, hips and core in stabilization.

#### Bench Position:

Removed

#### Accessory:

Long Hand Grips

#### Adjustable Arm Position:

4 or 5



START



FINISH

#### Success Tips

- Stabilize body from your feet all the way up through your trunk.
- Maintain a 90° angle between upper arms and torso throughout the motion.
- Keep chest muscles tight, limit and control your range of motion.
- Keep knees slightly bent, feet flat on the floor and in a staggered step for stability.
- Keep shoulder blades pinched, chest lifted and a slight curve in the lower back.
- Do not allow your torso to rotate or bend side to side during the motion.

#### START

- Grasp the Hand Grips so the cables are in line close to the front of your forearms.
- Stand with one foot forward and one foot back for added stability.
- Start with elbows bent to 90° and slightly behind or even with the shoulders, and the other arm straight in front of you at a slight inclined angle about head high.

#### FINISH

- Press one arm slightly upward away from your chest, as the other arm moves out and back. This is an alternating motion, so your arms will move in the opposite direction during the set.
- Slowly return each arm to the Start position keeping tension on the chest throughout the motion.

### Decline Chest Press – Shoulder Horizontal Adduction (and elbow extension)

#### Muscles worked:

Pectoralis Major; Deltoids; Triceps.

#### Bench Position:

45°

#### Accessory:

Long Hand Grips

#### Adjustable Arm Position:

7 or 8

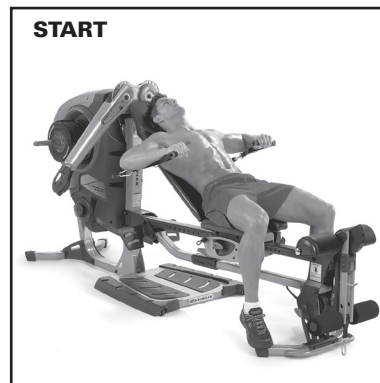

START



FINISH

#### Success Tips

- Maintain a 90° angle between upper arms and torso at the start of the press, and slightly less than 90° at the finish.
- Keep chest muscles tight, limit and control your range of motion.
- Keep knees slightly bent, feet flat on the floor.
- Keep shoulder blades pinched, chest lifted and a slight curve in the lower back.

#### START

- Grasp the Hand Grips so the cables travel under the forearm.
- Keep your forearms in line with the cable at all times.
- Start with elbows back and upper arms 90° from your torso.
- Elbows should be 10° lower than the standard bench press position.

#### FINISH

- Press forward, straightening your arms while moving your hands toward the center and slightly downward about 10° below your shoulders.
- Do not lock your elbows.
- Slowly return to the Start position, keeping tension on the chest throughout the motion.

## Chest Exercises

### Standing Decline Chest Press — Shoulder Horizontal Adduction (and elbow extension)

#### Muscles worked:

Pectoralis Major; Deltoids; Triceps. Also ankles, knees, hips and core in stabilization.

#### Bench Position:

Removed

#### Accessory:

Long Hand Grips

#### Adjustable Arm Position:

3, 4 or 5

#### Success Tips

- Stabilize body from your feet all the way up through your trunk.
- Maintain a 90° angle between your upper arms and torso at the start of the motion, and slightly less than 90° at the finish.
- Keep chest muscles tight, limit and control your range of motion.
- Keep knees slightly bent, feet flat on the floor and in a staggered step for stability.
- Keep shoulderblades pinched, chest lifted and a slight curve in the lower back.



START



FINISH

#### START

- Grasp the Hand Grips so the cables travel under the forearm.
- Keep your forearms in line with the cable at all times.
- Start with elbows back and upper arms 90° from your torso.
- Elbows should be 10° lower than the standard bench press position.
- Stand with one foot forward and one foot back for added stability.

#### FINISH

- Press forward, straightening your arms while moving your hands toward the center and slightly downward about 10° below your shoulders.
- Do not lock your elbows.
- Slowly return to the Start position, keeping tension on the chest throughout the motion.

### Standing Decline Chest Press w/ Alternating Motion — Shoulder Horizontal Adduction

#### Muscles worked:

Pectoralis Major; Deltoids; Triceps. Also ankles, knees, hips and core in stabilization.

#### Bench Position:

Removed

#### Accessory:

Long Hand Grips

#### Adjustable Arm Position:

3, 4 or 5

#### Success Tips

- Stabilize body from your feet all the way up through your trunk.
- Keep chest muscles tight, limit and control your range of motion.
- Keep knees slightly bent, feet flat on the floor and in a staggered step for stability.
- Keep shoulderblades pinched, chest lifted and a slight curve in the lower back.
- Do not allow your torso to rotate or bend side to side during the motion.



START



FINISH

#### START

- Grasp the Hand Grips so the cables are in line and close to the front of your forearms.
- Stand with one foot forward and one foot back for added stability.
- Start with one elbow bent to 90° and slightly behind or even with the shoulder, the other arm straight in front of you 10° lower. Do not lock the elbow.

#### FINISH

- Press one arm slightly downward away from your chest, as the other arm moves out and back. This is an alternating motion, so your arms will move in the opposite direction during the set.
- Slowly return each arm to the Start position, keeping tension on the chest throughout the motion.

## Chest Exercises

### Standing Chest Fly — Shoulder Horizontal Adduction (elbow stabilization)

#### Muscles worked:

Pectoralis Major; Deltoids. Also ankles, knees, hips and core in stabilization.

#### Bench Position:

Removed

#### Accessory:

Long Hand Grips

#### Adjustable Arm Position:

4, 5 or 6

#### Success Tips

- Stabilize body from your feet all the way up through your trunk.
- Maintain a 90° angle between upper arms and torso throughout the motion.
- Keep chest muscles tight, limit and control your range of motion.
- Keep knees slightly bent, feet flat on the floor and in a staggered step for stability.
- Keep shoulder blades pinched, chest lifted and a slight curve in the lower back.



#### START



#### START

- Grasp the Hand Grips so the cables lie close to the front of your forearms and palms facing forward.
- Stand with one foot forward and one foot back for added stability.
- Stabilize the elbows so they are slightly bent and slightly behind or equal to the shoulders.

#### FINISH



#### FINISH

- Slowly move the arms forward and inward, bringing the handles together in front of you.
- Slowly return to the Start position, keeping tension on the chest throughout the motion.

### Standing Single Arm Chest Fly — Shoulder Horizontal Adduction (elbow stabilization)

#### Muscles worked:

Pectoralis Major; Deltoids. Also ankles, knees, hips and core in stabilization.

#### Bench Position:

Removed

#### Accessory:

Long Hand Grips

#### Adjustable Arm Position:

4 or 5

#### Success Tips

- Stabilize body from your feet all the way up through your trunk.
- Maintain a 90° angle between upper arm and torso throughout the motion.
- Keep chest muscles tight, limit and control your range of motion.
- Keep knees slightly bent, feet flat on the floor and in a staggered step for stability.
- Keep shoulder blade pinched, chest lifted and a slight curve in the lower back.
- Do not lean sideways or turn the trunk during the motion.



#### START



#### START

- Grab the handle so the cable lies close to the front of your forearm and palm face forward.
- Stand with one foot forward and one foot back for added stability.
- Stabilize the elbow so it is slightly bent and slightly behind or equal to the shoulder.

#### FINISH



#### FINISH

- Slowly move the arm forward and inward, bringing the handle in front of you.
- Slowly return to the Start position, keeping tension on the chest throughout the motion.

## Chest Exercises

### Standing Incline Chest Fly – Shoulder Horizontal Adduction (elbow stabilization)

#### Muscles worked:

Pectoralis Major; Deltoids. Also ankles, knees, hips and core in stabilization.

#### Bench Position:

Removed

#### Accessory:

Long Hand Grips

#### Adjustable Arm Position:

4, 5 or 6

#### Success Tips

- Stabilize body from your feet all the way up through your trunk.
- Keep chest muscles tight, limit and control your range of motion.
- Keep knees slightly bent, feet flat on the floor and in a staggered step for stability.
- Keep shoulder blades pinched, chest lifted and a slight curve in the lower back.



#### START



#### START

- Grasp the Hand Grips so the cables lie close to the front of your forearms, and palms face forward.
- Stand with one foot forward and one foot back for added stability.
- Stabilize the elbows so they are slightly bent and slightly behind or even with the shoulders.

#### FINISH



#### FINISH

- Slowly move the arms slightly upward and inward, bringing the handles together in front of you at about neck/chin height.
- Slowly return to the Start position, keeping tension on the chest throughout the motion.

### Standing Decline Chest Fly – Shoulder Horizontal Adduction (elbow stabilization)

#### Muscles worked:

Pectoralis Major; Deltoids. Also ankles, knees, hips and core in stabilization.

#### Bench Position:

Removed

#### Accessory:

Long Hand Grips

#### Adjustable Arm Position:

4 or 5

#### Success Tips

- Stabilize body from your feet all the way up through your trunk.
- Keep chest muscles tight, limit and control your range of motion.
- Keep knees slightly bent, feet flat on the floor and in a staggered step for stability.
- Keep shoulder blades pinched, chest lifted and a slight curve in the lower back.



#### START



#### START

- Grasp the Hand Grips so the cables lie close to the front of your forearms and palms face forward.
- Stand with one foot forward and one foot back for added stability.
- Stabilize the elbows so they are slightly bent and slightly behind or equal to the shoulders.

#### FINISH



#### FINISH

- Slowly move the arms slightly downward and inward, bringing the handles together in front of you at about lower chest height.
- Slowly return to the Start position, keeping tension on the chest throughout the motion.



# Shoulder Exercises

## Rear Deltoid Rows – Shoulder Horizontal Abduction (and elbow flexion)

### Muscles worked:

Rear and Middle Deltoids; Posterior Rotator Cuff; Upper Latissimus; Teres Major; Trapezius; Rhomboids

### Bench Position:

Flat Bench Back

### Accessory:

Long Hand Grips

### Adjustable Arm Position:

6, 7, or 8

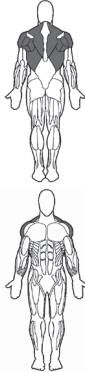

START



FINISH

### Success Tips

- Maintain a 90° angle between your upper arms and torso during motion.
- Keep knees bent and feet on floor.
- To work one arm at a time, place non-working hand on bench to stabilize.
- Keep shoulder blades pinched together and maintain good spinal alignment.

### START

- Sit on the bench facing the main engine.
- Grasp the Hand Grips. Keep palms down and arms straight.
- Sit up straight. Bend slightly forward from hips until arms are in front of body at a 90° angle from torso and in line toward the pulley.
- Lift your chest and keep your shoulder blades together.
- Keep forearms in line with cables.

### FINISH

- Allowing your arms to bend slowly, move your elbows outwards and backwards, keeping a 70-90° angle between your upper arms and torso.
- Move until your elbows are slightly behind your shoulders, then slowly reverse back to the Start position.
- Keep your shoulder blades tightened throughout motion.

## Standing Lateral Shoulder Raise – Shoulder Abduction (elbow stabilized)

### Muscles worked:

Middle Deltoids; Upper Trapezius

### Bench Position:

Remove Bench

### Accessory:

Long Hand Grips

### Adjustable Arm Position:

8

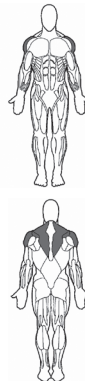

START



FINISH

### Success Tips

- Do not swing your arms upward or move your trunk during the motion.
- Keep your feet on floor.

### START

- Remove the bench and stand on the platform, straddling the seat rail and facing the engine.
- Grasp the Hand Grips, palms facing each other.
- Align your spine and bend forward slightly at the hips (15-20°).
- Elevate shoulders slightly toward back of head, keeping spine aligned.

### FINISH

- Slowly raise your arms out to your sides, at a 90° angle from your body.
- Keep your forearms facing outward throughout the movement.
- Slowly return to the Start position without relaxing muscle tension.

## Shoulder Exercises

### Seated Shoulder Press – Shoulder Adduction (and elbow extension)

#### Muscles worked:

Front Deltoids; Upper Trapezius; Triceps

#### Bench Position:

Flat Bench Back

#### Accessory:

Long Hand Grips

#### Adjustable Arm Position:

7. 8

#### Success Tips

- Keep knees bent and feet on floor.
- Do not increase the arch in your lower back as you raise your arms, but keep your spine steady and tight.
- Keep abdominals tight and maintain good spinal alignment.

#### Variation

Remove the long bench pad and slide the seat toward the engine. Attach the Leg Press Seat Back to the sliding seat, facing away from the engine. (Refer to instructions for attaching the Leg Press Seat Back accessory.) Sit on the seat, and lean against the seat back for added stability.



START



FINISH

#### START

- Sit on the bench facing away from the engine.
- Keep your chest up, abs tight and maintain a slight arch in lower back.
- Grasp Hand Grips, palms facing out.
- Raise the Hand Grips to head level so your elbows are equal to shoulder level. Keep your palms facing forward.

#### FINISH

- Straighten your arms slowly over your head, focusing on moving your elbows up and inward toward your ears.
- Slowly return to the Start position, keeping tension in your front shoulder muscles.

### Front Shoulder Raise – Shoulder Flexion (elbow stabilized)

#### Muscles worked:

Front and Middle Deltoids

#### Bench Position:

Flat Bench Back

#### Accessory:

Long Hand Grips

#### Adjustable Arm Position:

8 or 9

#### Success Tips

- Keep abdominals tight and maintain good spinal alignment.
- Keep knees bent and feet on floor.
- Do not increase the arch in your lower back as you raise your arms, but keep your spine steady and tight.

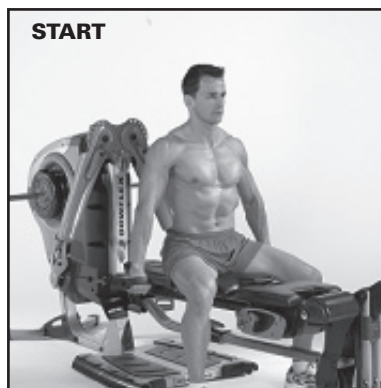

START



FINISH

#### START

- Sit on the bench, facing away from the engine.
- Keep your chest up, abs tight and maintain a slight arch in lower back.
- Grasp the Hand Grips, palms facing back, arms straight at your sides.

#### FINISH

- Keeping your arms straight, move them forward, leading with your forearms, until arms are extended in front of you at shoulder height.
- Arms may be moved alternately or together.
- Slowly return to the Start position next to the torso.

## Shoulder Exercises

### Shoulder Extension – (elbows stabilized)

#### Muscles worked:

Latissimus Dorsi; Teres Major; Rear Deltoid; Middle Trapezius; Rhomboids; Triceps



#### Bench Position:

Flat Bench Back

#### Accessory:

Long Hand Grips

#### Adjustable Arm Position:

8 or 9

#### Success Tips

- Keep knees bent and feet flat on floor.
- Keep your lats tightened throughout the motion.
- Keep abdominals tight and maintain good spinal alignment.
- Release your shoulder blades at the end of each rep and initiate new rep by retracting your shoulder blades.

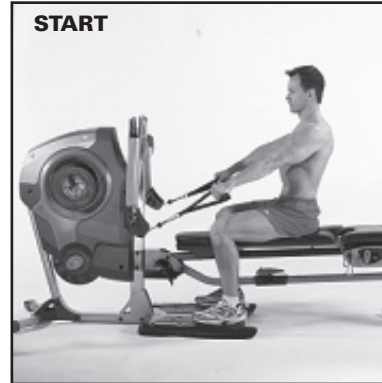

START

#### START

- Sit on the bench facing engine.
- Grasp the Hand Grips, palms facing down, arms straight and at approximately a 45° angle from torso.
- Tighten your trunk muscles to stabilize your spine while maintaining a slight arch in the lower back.



FINISH

#### FINISH

- Initiate movement by pinching shoulder blades together.
- Continue movement by moving your hands in an arc downward, along your sides, until hands are level with hips.
- With controlled movement, slowly return to the Start position.

### Shoulder Shrug – Scapular Elevation

#### Muscles worked:

Upper Trapezius



#### Bench Position:

Removed

#### Accessory:

Hand Grips

#### Adjustable Arm Position:

7 or 8

#### Success Tips

- Keep abdominals tight and maintain good spinal alignment.
- Do not bend your neck or slouch during this exercise.
- Raise shoulders evenly.
- For variation, try this exercise bent forward slightly from the hips.



START

#### START

- Stand on the platform, facing the engine.
- Reach down and grasp the Hand Grips, palms facing each other.
- Let your arms hang at your sides.

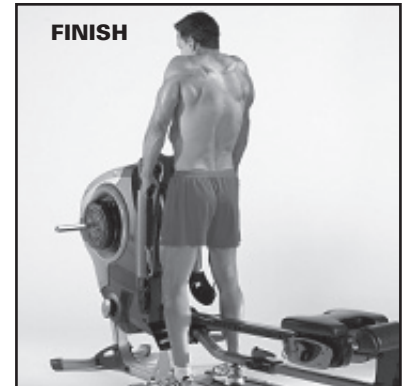

FINISH

#### FINISH

- Slowly raise your shoulders towards the back of your head, keeping your neck and head still.
- Slowly reverse back to the Start position, keeping your upper trapezius muscles tight throughout the motion.

## Shoulder Exercises

### Scapular Protraction – (elbows stabilized)

#### Muscles worked:

Serratus Anterior

#### Bench Position:

45° incline

#### Accessory:

Long Hand Grips

#### Adjustable Arm Position:

9

#### Success Tips

- Keep knees bent and feet flat on floor. Lean head back against the bench.
- Keep your spine aligned and a slight arch in your lower back.
- Maintain a 90° angle between upper arms and torso throughout exercise.
- Do not slouch forward or use your arm muscles to assist this motion. Keep this motion only in the shoulder blades.

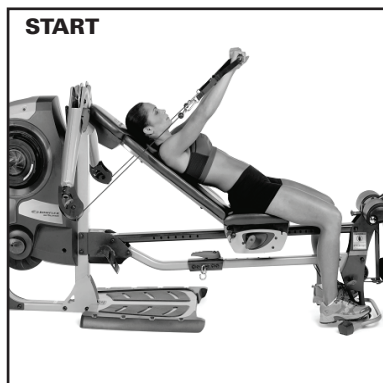

START

#### START

- Reach behind your body, grasp the Hand Grips and straighten your arms in front of you at a 90° angle from torso.
- Keep your arms in line with the cables, palms facing down and wrists straight.

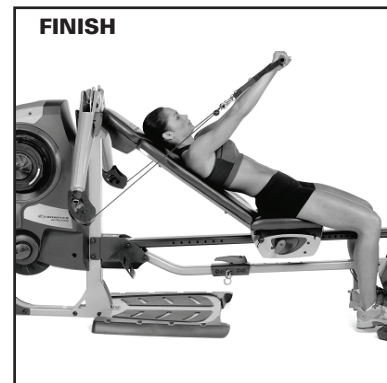

FINISH

#### FINISH

- Keeping your arms straight and in line with the cables, slowly move your shoulder blades forward off the bench, bringing your hands together using only your shoulder muscles.
- Slowly return to the Start position, keeping tension in your shoulder blades.

### Scapular Depression

#### Muscles worked:

Lower Trapezius

#### Bench Position:

Flat Bench Back

#### Accessory:

Long Hand Grips

#### Adjustable Arm Position:

8, 9

#### Success Tips

- Do not lose spinal alignment—keep your chest lifted and head on bench.
- Keep knees bent and feet flat on floor.

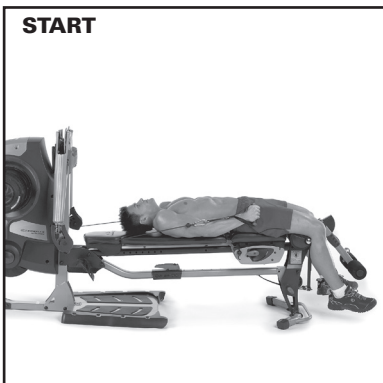

START

#### START

- Lie on the bench, head toward the engine.
- Grasp the Hand Grips and bring your arms straight down your sides along your trunk.
- Tighten your trunk muscles to stabilize your spine while maintaining a slight arch in your lower back.



FINISH

#### FINISH

- Keeping your arms straight, slide your shoulder blades downward, toward your hips.
- When your shoulder blades have fully depressed, slowly return to the Start position.

# Shoulder Exercises

## Lying Front Shoulder Raise – Shoulder Flexion (elbows stabilized)

### Muscles worked:

Front and Middle Deltoids

### Bench Position:

Flat Bench Back

### Accessory:

Long Hand Grips

### Adjustable Arm Position:

8

### Success Tips

- Keep knees bent and feet flat on floor.
- Keep abdominals tight and maintain good spinal alignment.
- Do not increase the arch in your lower back while you are lifting your arms.

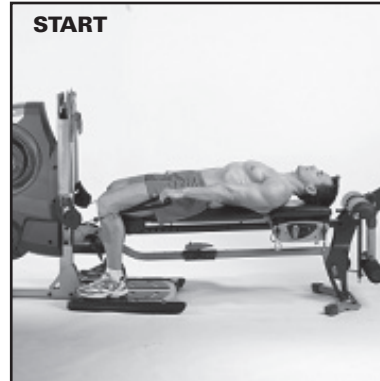
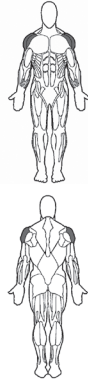

START

### START

- Sit on the bench facing engine.
- Grasp the Hand Grips, palms facing down, arms straight.
- Lie back slowly, supporting your head on the bench.
- Keep your chest lifted, maintaining a slight arch in your lower back.



FINISH

### FINISH

- Keeping your arms straight, move them in an arc upwards until they are directly over your shoulders.
- You may perform this move with both arms simultaneously or one at a time.
- With controlled movement, slowly return to the Start position.

## Reverse Fly Cable Cross – Shoulder Horizontal Abduction (elbows stabilized in slight flexion)

### Muscles worked:

Rear Deltoids; Middle Deltoids;  
Trapezius; Rhomboids

### Bench Position:

Flat Bench Back

### Accessory:

Hand Grips

### Adjustable Arm Position:

8

### Success Tips

- Do not lose spinal alignment—keep your chest lifted.
- Keep knees bent and feet flat on floor.
- Keep your spine aligned and a slight arch in your lower back.
- Maintain a 90° angle between upper arms and torso throughout exercise.



START

### START

- Sit on the Bench facing the engine.
- Grasp the opposite Hand Grips, palms facing each other, arms nearly straight.
- Sit up straight and bend slightly forward from the hips until arms/cables are in front of body at a 90° angle from torso.



FINISH

### FINISH

- Maintaining the bend in your arms, move your arms outward and backward.
- When your elbows are slightly behind your shoulders, slowly return to the Start position, keeping your rear shoulder muscles tightened throughout movement.

## Shoulder Exercises

### Seated Lateral Shoulder Raise — Shoulder Abduction (elbows stabilized)

#### Muscles worked:

Supraspinatus; Middle Deltoids;  
Trapezius

#### Bench Position:

Flat Bench Forward

#### Accessory:

Hand Grips

#### Adjustable Arm Position:

8

#### Success Tips

- Keep knees bent and feet flat on floor.
- Keep abdominals tight and maintain good spinal alignment.
- Do not increase swing arms upward or move trunk during movement.



START



START

- Sit on the bench facing engine.
- Slide the Hand Grips over your forearms, near the elbow.
- Keep your chest lifted, maintaining a slight arch in your lower back.

FINISH



FINISH

- Raise your arms directly out and upward to nearly shoulder level.
- At the top of the movement, you may need to rotate your hands slowly to prevent the cuff from sliding off.
- With controlled movement, slowly return to the Start position.

### Scapular Retraction

#### Muscles worked:

Rhomboids; Trapezius

#### Bench Position:

Flat Bench Back

#### Accessory:

Hand Grips

#### Adjustable Arm Position:

8, 9

#### Success Tips

- Keep knees bent and feet flat on floor.
- Keep your spine aligned, abs tight and a slight arch in your lower back.
- Keep your lats tightened throughout this exercise.
- Release your shoulder blades at the end of each rep. Initiate each new rep by retracting your shoulderblades.



START



START

- Sit on the bench, facing engine.
- Grasp the Hand Grips, palms facing down.
- Brace your heels on the platform, knees bent comfortably, arms straight toward the pulleys.
- Allow your shoulder blades to move forwards, while leaning forward from the hips.

FINISH



FINISH

- Keeping your chest lifted, pinch your shoulder blades backward while keeping your arms straight toward the pulleys.
- Slowly return to the Start position without slouching or changing spinal alignment.

## Shoulder Exercises

### Standing Shoulder Press — Shoulder Abduction (and elbow extension)

#### Muscles worked:

Deltoids; Triceps. Also ankles, knees, hips and core in stabilization.

#### Bench Position:

Removed

#### Accessory:

Long Hand Grips

#### Adjustable Arm Position:

5, 6 or 7

#### Success Tips

- Stabilize body from your feet all the way up through your trunk.
- Keep shoulder muscles tight. Limit and control your range of motion.
- Keep knees slightly bent and feet flat on the floor.
- Keep abdominals tight and maintain good spinal alignment.
- Do not increase the arch in your low back as you raise your arms, but keep your spine stable and tight.



#### START



#### START

- Grasp the Hand Grips so the cables are in line close to the front of your forearms and palms face forward.
- Stand with feet flat on the platform, knees slightly bent.
- Keep chest up, abs tight and maintain a slight arch in the low back.
- Raise the hand grips to head level so your elbows are equal to shoulder level, keeping the palms facing forward.

#### FINISH



#### FINISH

- Straighten your arms slowly over your head, focusing on moving your elbows up and inward toward your ears.
- Slowly return to the Start position, keeping tension on the front shoulder muscles throughout the motion.

### Standing Shoulder Press w/ Alternating Motion — Shoulder Abduction (and elbow extension)

#### Muscles worked:

Deltoids; Triceps. Also ankles, knees, hips and core in stabilization.

#### Bench Position:

Removed

#### Accessory:

Long Hand Grips

#### Adjustable Arm Position:

5, 6 or 7

#### Success Tips

- Stabilize body from your feet all the way up through your trunk.
- Keep shoulder muscles tight. Limit and control your range of motion.
- Keep knees slightly bent and feet flat on the floor.
- Keep abdominals tight and maintain good spinal alignment.
- Do not increase the arch in your low back as you raise your arms, but keep your spine stable and tight.
- Do not allow your body to bend sideways during the motion.



#### START



#### START

- Grasp the Hand Grips so the cables are in line close to the front of your forearms and palms face forward.
- Stand with feet flat on the platform, knees slightly bent.
- Keep chest up, abs tight and maintain a slight arch in the low back.
- Raise one hand grip to head level so your elbow is equal to shoulder level, keeping the palms facing forward, while the other arm is extended upward over your head.

#### FINISH

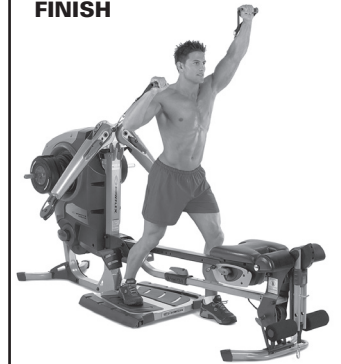

#### FINISH

- Straighten one arm slowly over your head, focusing on moving your elbow up and inward toward your ear.
- Lower the opposite arm so that your elbow is slightly below or equal to your shoulder.
- Slowly return to the Start position, keeping tension on the front shoulder muscles throughout the motion.

## Shoulder Exercises

### Standing Front Shoulder Raise — Shoulder Flexion

#### Muscles worked:

Deltoids. Also ankles, knees, hips and core in stabilization.

#### Bench Position:

Removed

#### Accessory:

Long Hand Grips

#### Adjustable Arm Position:

7, 8 or 9

#### Success Tips

- Stabilize body from your feet all the way up through your trunk.
- Keep shoulder muscles tight. Limit and control your range of motion.
- Keep knees slightly bent and feet flat on the floor.
- Keep abdominals tight and maintain good spinal alignment.
- Do not increase the arch in your low back as you raise your arms, but keep your spine stable and tight.



#### START



#### START

- Stand on the platform facing away from the engine.
- Grasp the Hand Grips with the palms facing backward.
- Stand with feet flat on the platform, knees slightly bent and arms to your sides.
- Keep chest up, abs tight and maintain a slight arch in the low back.

#### FINISH



#### FINISH

- Keeping your arms straight, move them forward, leading with your forearms, until arms are extended in front of you at shoulder level.
- Arms may be moved together or alternately
- Slowly return to the Start position, keeping tension on the front shoulder muscles throughout the motion.

### Standing Rear Deltoid Row — Shoulder Horizontal Abduction (and elbow flexion)

#### Muscles worked:

Rear and Middle Deltoids; Posterior Rotator Cuff; Upper Lats; Teres Major; Rhomboids; Trapezius. Also ankles, knees, hips and core in stabilization.

#### Bench Position:

Removed

#### Accessory:

Long Hand Grips

#### Adjustable Arm Position:

2 or 3

#### Success Tips

- Stabilize body from your feet all the way up through your trunk.
- Keep shoulder and upper back muscles tight. Limit and control your range of motion.
- Keep knees slightly bent and feet flat on the floor, stagger your foot position for added stability.
- Keep abdominals tight and maintain good spinal alignment.
- Do not increase the arch in your low back as you move your arms, but keep your spine stable and tight.



#### START



#### START

- Grasp the Hand Grips so your palms are facing down and arms are straight.
- Stand with feet flat on the floor, knees slightly bent facing the engine.
- Keep chest up, abs tight, maintain a slight arch in the low back and keep your shoulderblades pinched together.
- Lean back slightly at the hips so that the cables are in line with your arms and shoulders.

#### FINISH



#### FINISH

- Allowing your arms to bend slowly, move your elbows out and backward keeping a 70°-90° angle between your upper arms and your torso.
- Move until your elbows are slightly behind your shoulders.
- Slowly return to the Start position, keeping tension on the shoulderblades.



## Shoulder Exercises

### Standing Cablecross Rear Deltoid Row – Shoulder Horizontal Abduction (and elbow flexion)

#### Muscles worked:

Rear and Middle Deltoids; Posterior Rotator Cuff; Upper Lats; Teres Major; Rhomboids; Trapezius. Also ankles, knees, hips and core in stabilization.

#### Bench Position:

Removed

#### Accessory:

Long Hand Grips

#### Adjustable Arm Position:

2 or 3



#### START



#### FINISH



#### START

- Grab the opposite side handles so your palms are facing down and arms are straight.
- Stand with feet flat on the floor, knees slightly bent facing the engine.
- Keep chest up, abs tight, maintain a slight arch in the low back and keep your shoulderblades pinched together.
- Lean back slightly at the hips so the cables are in line with your arms and shoulders.

#### FINISH

- Allowing your arms to bend slowly, move your elbows out and backward keeping a 70°-90° angle between your upper arms and your torso.
- Move until your elbows are slightly behind your shoulders.
- Slowly return to the Start position, keeping tension on the shoulder blades.

#### Success Tips

- Stabilize body from your feet all the way up through your trunk.
- Keep shoulder and upper back muscles tight, limit and control your range of motion.
- Keep knees slightly bent and feet flat on the floor, stagger your foot position for added stability.
- Keep abdominals tight and maintain good spinal alignment.
- Do not increase the arch in your low back as you move your arms; keep your spine stable and tight.

### Standing Shoulder Extension – Elbow Stabilization

#### Muscles worked:

Rear Deltoids; Teres Major; Rhomboids; Middle Trapezius; Triceps. Also ankles, knees, hips and core in stabilization.

#### Bench Position:

Removed

#### Accessory:

Long Hand Grips

#### Adjustable Arm Position:

7, 8 or 9



#### START



#### FINISH



#### START

- Stand on the platform facing the engine
- Grasp the Hand Grips with a Hammer Type grip, arms straight, at approximately a 45° angle in front of the torso.
- Tighten your trunk muscles to stabilize your spine while maintaining a slight arch in the low back.

#### FINISH

- Initiate the movement by pinching the shoulderblades together.
- Continue movement by moving your hands in an arc downward, along your sides, until your hands are level with your hips.
- With controlled movement, slowly return to the Start position.

#### Success Tips

- Stabilize body from your feet all the way up through your trunk.
- Keep knees slightly bent and feet flat on the floor.
- Keep abdominals tight and maintain good spinal alignment.
- Release your shoulderblades at the end of each rep, and initiate each new rep by retracting your shoulderblades.

## Shoulder Exercises

### Shoulder Internal Rotation w/ Full Shoulder Adduction

#### Muscles worked:

Subscapularis Superior fibers;  
Pectoralis Major

#### Bench Position:

Flat

#### Accessory:

Long Hand Grips

#### Adjustable Arm Position:

5 or 6

#### Success Tips

- Control the motion during the entire exercise. Do not use momentum.
- Do not rotate your spine to gain additional range of motion. Try for pure rotation of your shoulder—more is not better.
- Use light resistance to perform 12-15 perfect repetitions.
- Standing at different angles to the machine will alter the resistance application to the muscle.



#### START



#### START

- Stand off to one side of the machine.
- Grasp the handle with the hand closest to the machine and draw your upper arm into your side.
- Stand up straight with chest lifted, slight arch in the lower back and shoulderblades retracted.
- Distance yourself from the arm of the machine to eliminate slack in the cable\handgrip.

#### FINISH



#### FINISH

- Rotate your forearm towards your abdomen, keeping your elbow at your side during the entire motion.
- Slowly return to the Start position.
- Repeat with the other arm after you have completed the set.

### Shoulder Internal Rotation w/ 90° of Abduction

#### Muscles worked:

Subscapularis Middle\Inferior fibers;  
Pectoralis Major

#### Bench Position:

Removed

#### Accessory:

Long Hand Grips

#### Adjustable Arm Position:

2 or 3

#### Success Tips

- Control the motion during the entire exercise. Do not use momentum.
- Do not rotate your spine to gain additional range of motion. Try for pure rotation of your shoulder—more is not better.
- Moving the arm of the machine to different positions above your shoulder will alter the resistance application to the muscle.



#### START



#### START

- Stand off to one side of the machine.
- Grasp the handle with the hand closest to the machine and position your upper arm 90° away from your side.
- Stand up straight with chest lifted, slight arch in the lower back and shoulderblades retracted.
- Distance yourself from the arm of the machine to eliminate slack in the cable\handgrip.

#### FINISH



#### FINISH

- Rotate your forearm forward then downward, keeping your upper arm stable.
- Do not let your arm move closer toward your side during the motion.
- Slowly return to the Start position.
- Repeat with the other arm after you have completed the set.

# Shoulder Exercises

## Shoulder External Rotation w/ Full Shoulder Adduction

### Muscles worked:

Posterior Deltoid; Teres minor; Infraspinatus

### Bench Position:

Removed

### Accessory:

Long Hand Grips

### Adjustable Arm Position:

5 or 6

### Success Tips

- Control the motion during the entire exercise. Do not use momentum.
- Do not rotate your spine to gain additional range of motion. Try for pure rotation of your shoulder—more is not better.
- Use light resistance to perform 12-15 perfect repetitions.
- Standing at different angles to the machine will alter the resistance application to the muscle.

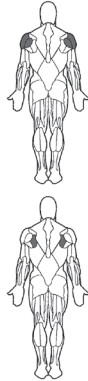

### START



### START

- Stand off to one side of the machine.
- Facing the machine, grasp the handle and position your upper arm at your side.
- Stand up straight with chest lifted, slight arch in the lower back and shoulderblades retracted.
- Distance yourself from the arm of the machine to eliminate slack in the cable/handgrip.

### FINISH



### FINISH

- Rotate your forearm out and back, keeping your upper arm stable.
- Do not let your arm move away your side during the motion.
- Slowly return to the Start position keeping tension on the muscle.
- Repeat with the other arm after you have completed the set.

## Shoulder External Rotation w/ 90° of Abduction

### Muscles worked:

Posterior Deltoid; Teres minor; Infraspinatus

### Bench Position:

Removed

### Accessory:

Long Hand Grips

### Adjustable Arm Position:

4 or 5

### Success Tips

- Control the motion during the entire exercise. Do not use momentum.
- Do not rotate your spine to gain additional range of motion. Try for pure rotation of your shoulder—more is not better.
- Use light resistance to perform 12-15 perfect repetitions.
- Moving the arm of the machine to different positions will alter the resistance application to the muscle.

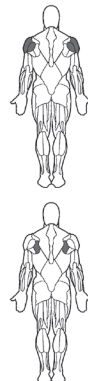

### START

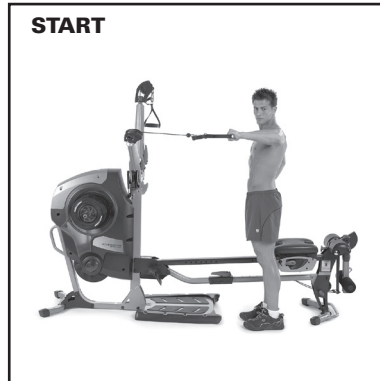

### START

- Stand off to one side of the machine.
- Facing the machine, grab the handle and position your upper arm 90° away from your side.
- Stand up straight with chest lifted, slight arch in the lower back and shoulderblades retracted.
- Distance yourself from the arm of the machine to eliminate slack in the cable/handgrip.

### FINISH



### FINISH

- Rotate your forearm up and away, keeping your upper arm stable.
- Do not let your arm move closer toward your side during the motion.
- Slowly return to the Start position, keeping tension on the muscle.
- Repeat with the other arm after you have completed the set.

## Back Exercises

### Standing Wide Angle Lat Row – Shoulder extension (and elbow flexion)

#### Muscles worked:

Latissimus Dorsi, Rear Deltoids, Biceps Teres Major. Also Hip and core stabilizers.

#### Bench Position:

Removed

#### Accessory:

Long hand grips

#### Adjustable Arm Position:

4 or 5

#### Success Tips

- Do not bend your neck forward or backward.
- Start each rep by retracting your shoulder blades.
- Release your shoulder blades at the end of each rep.
- Keep your spine in alignment and chest lifted.

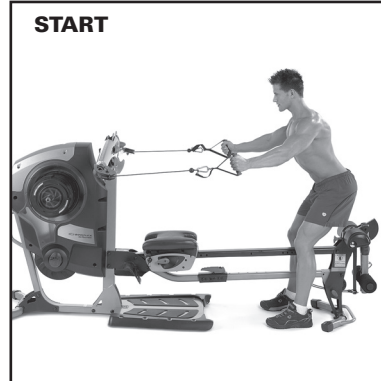

START

- START**
- Stand on the floor facing the engine.
  - Grasp the Hand Grips with the arms forward toward the pulleys.
  - Keep chest lifted, abs tight and a slight arch in the lower back.

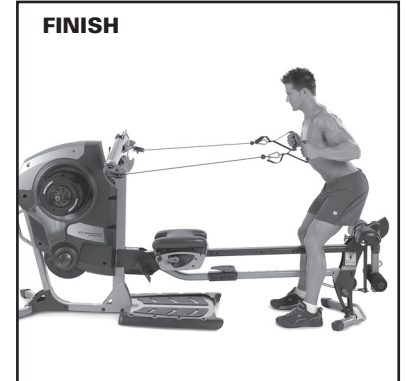

FINISH

- FINISH**
- Slowly move your elbows back and inward toward your outside edge of the rib cage.
  - Slowly extend the arms back to the Start position.
  - Keep knees bent and back straight.

### Narrow Pulldowns with Hand Grips – Shoulder Extension (with elbow flexion)

#### Muscles worked:

Latissimus Dorsi; Teres Major; Rear Deltoids; Biceps

#### Bench Position:

Flat Bench Forward

#### Accessory:

Hand Grips

#### Adjustable Arm Position:

0

#### Success Tips

- Keep your chest lifted, abs tight, and a very slight arch in your lower back.
- Keep knees bent and feet flat on platform.
- Keep the lats tightened throughout the entire motion.



START

- START**
- Straddle the bench facing the engine, grasp a Hand Grip in each hand, palms facing each other and sit down on the bench.
  - Slide back on the cables to get tension on the cables.



FINISH

- FINISH**
- Keep hands at shoulder width, arms straight. Initiate movement by pulling your shoulderblades back while simultaneously bending your elbows, drawing them down and inward towards your sides.
  - At the end of the motion, arms should be near your sides, shoulderblades back, forearms facing upward.
  - Slowly return to Start position.

## Back Exercises

### Seated Lat Rows – Shoulder Extension (and elbow flexion)

#### Muscles worked:

Latissimus Dorsi; Teres Major;  
Rear Deltoids; Biceps

#### Bench Position:

Flat Bench Back

#### Accessory:

Hand Grips

#### Adjustable Arm Position:

8, 9 (low lat rows)

1, 2 (high lat rows)

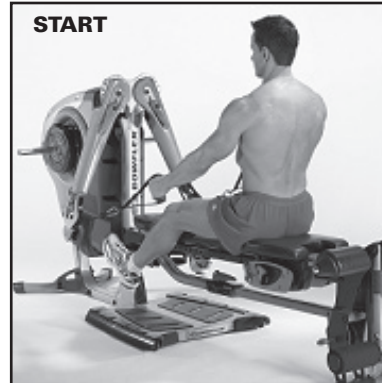

START

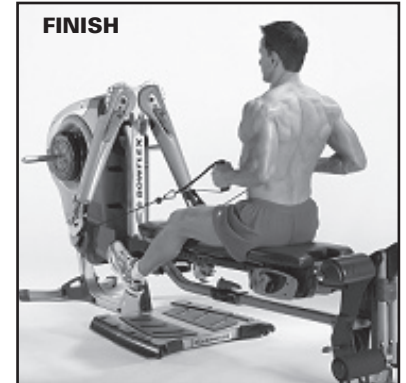

FINISH

#### Success Tips

- Keep knees bent and feet flat on the footrest.
- Do not bend your torso forward.
- Keep your chest lifted and maintain spinal alignment.
- Release your shoulder blades at the end of each rep. Initiate each new rep by pinching your shoulder blades

#### START

- Sit on the bench facing the engine, near the back (leg extension) end of the bench.
- Grasp the Hand Grips, palms facing each other.
- Place your feet on the footrest and bend your knees comfortably.

#### FINISH

- Initiate the movement by pinching your shoulder blades together.
- Pull your upper arms downward and backward, brushing past the sides of the body while keeping your forearms pointing in the direction of the cable.
- Slowly return to the Start position.

### Lying Lat Fly

#### Muscles worked:

Latissimus Dorsi; Teres Major

#### Bench Position:

Flat Back Bench

#### Adjustable Arm Position:

Hand grips, connected at shortened ring.

#### Adjustable Arm Position:

7, 8

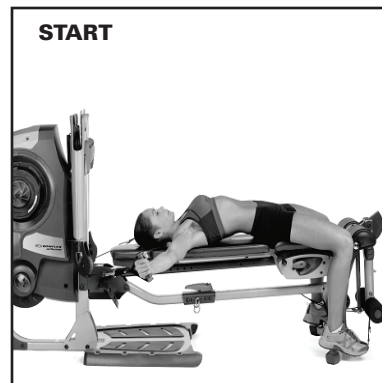

START



FINISH

#### Success Tips

- Keep your lats tightened throughout the entire motion.
- Maintain good spinal alignment, abs tight, slight arch in your lower back.

#### START

- Lie flat on your back on the bench, head toward the engine.
- Position yourself far enough down the bench to grasp the Hand Grips at shoulder level with arms straight out.
- Grasp the Hand Grips, palms facing down.
- Tighten abs to stabilize your spine. Maintain a slight arch in your lower back.

#### FINISH

- Initiate the movement by pulling your shoulder blades down and together while simultaneously drawing your elbows in an arc, towards the sides of your body.
- Slowly return to the Start position allowing your arms and shoulder blades to move fully upward.

## Back Exercises

### Stiff Arm Pulldown

#### Muscles worked:

Latissimus Dorsi

#### Bench Position:

Removed

#### Accessory:

Hand Grips

#### Adjustable Arm Position:

0, 1

#### Success Tips

- Do not lose spinal alignment.
- Keep your lats tightened throughout the entire motion.
- Release your shoulder blades at the end of each rep and initiate each new rep by lowering your shoulder blades.
- Keep your elbows nearly straight (not locked).



START

#### START

- Remove the bench and stand facing the engine straddling the rail.
- Grasp the Hand Grips with your palms down and step back slightly.
- Lift your chest and tighten your abdominals to stabilize your spine while maintaining a very slight arch in your lower back.



FINISH

#### FINISH

- Initiate the movement by lowering your shoulders down and together.
- Keeping your arms straight, continue by slowly moving your hands in an arc toward your legs.
- Slowly return to the Start position without relaxing.

### Standing Lat Row High Pulley

#### Muscles worked:

Latissimus Dorsi; Rear Deltoids;  
Biceps; Teres Major

#### Bench Position:

Remove seat

#### Accessory:

Hand Grips

#### Adjustable Arm Position:

0, 1

#### Success Tips

- Do not bend your neck forward or backward.
- Release your shoulder blades at the end of each rep.
- Start each rep by retracting your shoulderblades.
- Keep your spine aligned, chest lifted.



START

#### START

- Remove the seat, stand on the floor facing the engine, and grasp the Hand Grips, arms hanging toward pulleys.



FINISH

#### FINISH

- Slowly move your elbows backward, keeping the chest lifted.
- Slowly return the handles to the Start position, keeping knees bent and a slight arch in your lower back
- Stop your arm motion when the elbows reach your sides.

## Back Exercises

### Standing Lat Row Low Pulley — Shoulder Extension (and elbow flexion)

#### Muscles worked:

Latissimus Dorsi; Rear Deltoids; Biceps; Teres Major. Also hip and core stabilizer muscles.

#### Bench Position:

Removed

#### Accessory:

Long Hand Grips

#### Adjustable Arm Position:

8, 9

#### Success Tips

- Do not bend your neck forward or backward.
- Start each rep by retracting your shoulder blades.
- Release your shoulderblades at the end of each rep.
- Keep your spine in alignment and chest lifted.

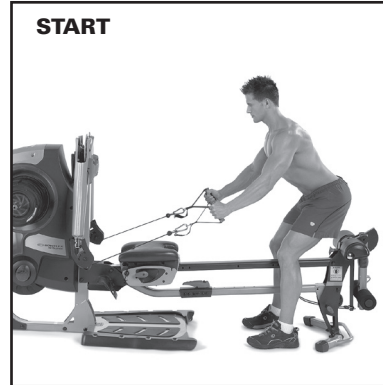

START

#### START

- Stand on the floor facing the engine.
- Grasp the Hand Grips with your arms hanging forward toward the pulleys.
- Bend over to about 45° and keep tension on the cables.

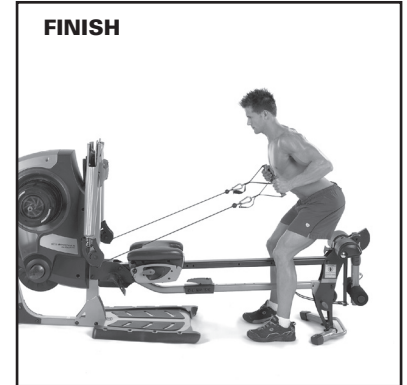

FINISH

#### FINISH

- Slowly move your elbows backward as you bring the hands to a point just below your chest.
- Slowly extend the arms back to the Start position.
- Keep knees bent and back straight.

### Standing Lat Row Alternating Motion-Low Pulley — Shoulder Extension (and elbow flexion)

#### Muscles worked:

Latissimus Dorsi; Rear Deltoids; Biceps; Teres Major. Also hip and core stabilizer muscles.

#### Bench Position:

Removed

#### Accessory:

Long Hand Grips

#### Adjustable Arm Position:

8, 9

#### Success Tips

- Do not bend your neck forward or backward.
- Start each rep by retracting your shoulderblade of the arm moving backward.
- Release your shoulderblades at the end of each rep of the arm going forward.
- Keep your spine in alignment and chest lifted.



START

#### START

- Stand on the floor facing the engine.
- Grasp the Hand Grips with one arm hanging forward toward the pulley, and the other arm back with the elbow bent and forearm in line with the cable.
- Bend over to about 45° and keep tension on the cables

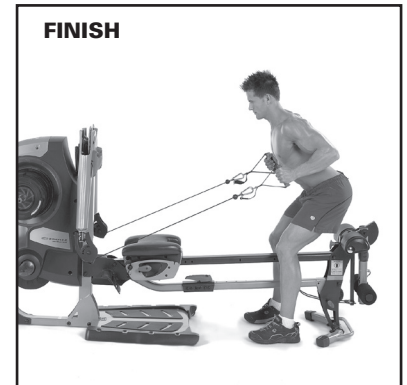

FINISH

#### FINISH

- Slowly move one elbow backward bringing the hand to a point just below your chest, while the other arm moves forward with your hand moving toward the pulley.
- This is an alternating motion, with the arms moving in opposite directions.
- Keep knees bent and back straight.

## Back Exercises

### Standing Single Arm Lat Row Low Pulley — Shoulder Extension

#### Muscles worked:

Latissimus Dorsi; Rear Deltoids; Biceps; Teres Major. Also hip and core rotator muscles.



#### Bench Position:

Removed

#### Accessory:

Long Hand Grips

#### Adjustable Arm Position:

8, 9

#### Success Tips

- Do not bend your neck forward or backward.
- Start each rep by retracting your shoulderblade.
- Release your shoulderblade at the end of each rep.
- Keep your spine in alignment and chest lifted.
- Do not throw the resistance or use momentum to gain more trunk rotation—more is not better.



START



FINISH

#### START

- Stand on one side of the seat rail, facing the engine, with the foot closest to the seat rail forward.
- Grasp the handle with the hand grip away from the seat rail—arm hanging forward toward the pulley.
- Bend over to about 45°, and keep tension on the cables.

#### FINISH

- Slowly move your elbow backward as you bring the hands to a point just below your chest while rotating your trunk in the same direction that you are pulling.
- Slowly extend the arm back to the Start position and rotate your trunk back to the center.
- Keep knees bent and back straight.

### Standing Single Arm/ Single Leg Lat Row Low Pulley — Shoulder Extension

#### Muscles worked:

Latissimus Dorsi; Rear Deltoids; Biceps; Teres Major. Also hip and core rotator muscles, and hip and knee flexor muscles.



#### Bench Position:

Removed

#### Accessory:

Long Hand Grips

#### Adjustable Arm Position:

8, 9

#### Success Tips

- Do not bend your neck forward or backward.
- Start each rep by retracting your shoulderblade.
- Release your shoulderblade at the end of each rep.
- Keep your spine in alignment and chest lifted.
- Do not throw the resistance or use momentum to gain more trunk rotation—more is not better.

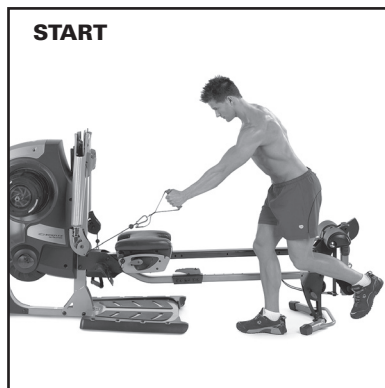

START



FINISH

#### START

- Stand on one side of the seat rail facing the engine with the opposite foot forward of the side you are pulling from.
- Grab the handle with the arm hanging forward toward the pulley.
- Bend over to about 45°, keep tension on the cables.

#### FINISH

- Slowly move your elbow backward as you rotate your trunk in the same direction, while flexing your hip/leg forward.
- Slowly extend the arm back to the Start position and counter rotate your trunk back, while extending your hip/leg back.
- Keep knee on the standing leg bent, while keeping the back straight.



## Back Exercises

### Seated Low Back Extension

#### Muscles worked:

Errector Spinae

#### Bench Position:

removed, seated on seat pad

#### Accessory:

Long hand grips

#### Adjustable Arm Position:

8 or 9

#### Success Tips

- Keep knees bent, feet flat on the platform and shoulder blades pinched.
- Keep your spine in alignment, chest lifted, abs tight and a slight arch in your low back.
- Move only from the hips, do not bend at the waist.



START



FINISH

#### START

- While sitting on the seat pad, move the handles to one side and slide the strap above your forearms near your elbows.
- Cross your arms in front of your chest bringing the handles toward your chest.
- Pinch your shoulder blades together and lean forward from the hips, at least 45°.

#### FINISH

- Keeping your chest lifted, move your entire torso backward by pivoting at the hips.
- Move as far as you can under control.
- Slowly move back to the Start position without slouching or changing spinal alignment.

### Standing Low Back Extension

#### Muscles worked:

Errector Spinae. Also hip, knee and ankle stabilizers.

#### Bench Position:

Removed

#### Accessory:

Long hand grips

#### Adjustable Arm Position:

8 or 9

#### Success Tips

- Keep knees bent, feet flat on the floor and shoulder blades pinched.
- Keep your spine in alignment, chest lifted, abs tight and a slight arch in your low back.
- Move only from the hips, do not bend at the waist.

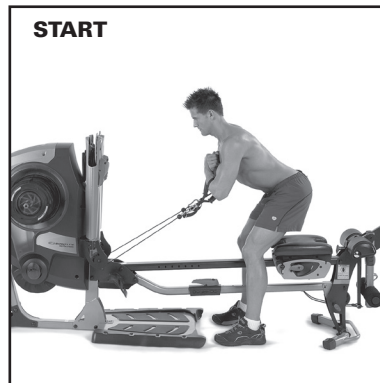

START



FINISH

#### START

- While standing on the floor, move the handles to one side and slide the strap above your forearms near your elbows.
- Cross your arms in front of your chest bringing the handles toward your chest.
- Pinch your shoulder blades together and lean forward from the hips, at least 45°.

#### FINISH

- Keeping your chest lifted and knees slightly bent, move your entire torso upwards by pivoting at the hips. Move as far as you can under control.
- Slowly move back to the Start position without slouching or changing spinal alignment.

## Back Exercises

### Lying Shoulder Pullover

#### Muscles worked:

Latissimus Dorsi; Teres Major; Deltoids; Triceps; Chest

#### Bench Position:

Flat

#### Accessory:

Long Hand Grips

#### Adjustable Arm Position:

8, 9

#### Success Tips

- Release your shoulderblades at the end of each repetition and initiate each new rep by depressing your shoulderblades.
- Keep your spine in alignment, chest lifted, abs tight and a slight arch in your low back.
- Keep the lats tight throughout the motion.



#### START



#### START

- With the bench flat, lie on your back with your head facing the engine.
- Position yourself far enough down the bench to allow the arms to extend overhead.
- Keep knees bent and feet on or near the floor.

#### FINISH



#### FINISH

- Move both arms in a arc upward and then down toward your legs.
- Keep shoulderblades on the bench and slide them toward your hips as you move your arms.
- Control the return motion to the Start position by slowly moving the arms overhead and releasing the shoulderblades.

### Reverse Grip Lat Pulldown – Shoulder extension with elbow flexion

#### Muscles worked:

Latissimus Dorsi, Teres Major, Rear Deltoids and Biceps

#### Bench Position:

Flat

#### Accessory:

Long hand grips

#### Adjustable Arm Position:

0 or 1

#### Success Tips

- Keep chest lifted, abs tight and a very slight arch in your lower back.
- Keep knees bent and feet flat on the floor.
- Keep the lats tight throughout the motion.



#### START



#### START

- Straddle the bench facing the engine, grab the hand grips with the palms facing upward and sit down on the bench.
- Slide back on the bench to get tension on the cable.

#### FINISH



#### FINISH

- Keep hands at shoulder width, arms straight.
- Initiate the movement by pulling your shoulder blades back while bending your elbows, drawing them down and in toward your sides.
- At the end of the motion, arms should be near your sides, shoulder blades back and palms facing up.
- Slowly return to the Start position.

## Back Exercises

### Wide Pulldowns — Shoulder Adduction (with elbow flexion)

#### Muscles worked:

Latissimus Dorsi; Teres Major;  
Rear Deltoids; Biceps

#### Bench Position:

Flat Bench Forward

#### Accessory:

Hand Grips

#### Adjustable Arm Position:

1, 2

#### Success Tips

- Keep knees bent and feet flat on floor.
- To determine the appropriate grip width for you, hold your arms straight out to your sides at shoulder height. Bend your elbows approximately 90°. Hands should be no wider apart than your elbows (beginners may narrow their grip to increase comfort).
- Keep your spine aligned, abs tight and a slight arch in your lower back.

#### Variation

Remove the long bench pad. Attach the Leg Press Seat Back to the sliding seat, facing away from the engine. (Refer to instructions for attaching the Leg Press Seat Back accessory.) Lock the seat in position at the far end of the seat rail. After grasping the Hand Grips, sit on the seat, facing the engine. Lean forward at the hip, and use the seat back for added stability.



#### START

- Grasp the Hand Grips using the wide grip determined by following the directions in the Success Tips, then sit on the bench, facing the engine.
- Lean forward at the hip.
- Arms should be in line with the pulley.



#### FINISH

- Initiate movement by depressing the shoulder blades while simultaneously drawing elbows down and inward toward your sides.
- Hand grips may not touch your chest. At the end of the motion, arms should be near your sides, shoulder blades fully depressed.
- Keep forearms facing upward.
- Slowly return to Start position.

## Arm Exercises

### Triceps Pushdown – Elbow Extension

#### Muscles worked:

Triceps

#### Bench Position:

Removed

#### Accessory:

Hand Grips

#### Adjustable Arm Position:

0, 1

#### Success Tips

- Keep your upper arms motionless and your wrists straight.
- Keep your chest lifted, abs tight and maintain a slight arch in lower back.
- Tighten the triceps throughout the exercise, using controlled motion.

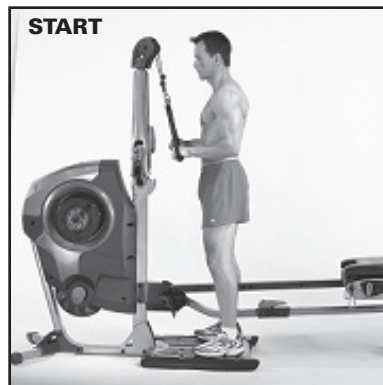

#### START

- Straddle the Seat Rail, facing the engine.
- Grasp the Hand Grips, palms facing down.
- Bring hands in front of you, keeping hand grips approximately at rib level.



#### FINISH

- Keeping your upper arms stationary, elbows next to trunk, slowly push your arms downward in a gentle arc until hands are near tops of your thighs.
- Keeping your triceps tightened, slowly reverse the arcing motion.

### French Press – Elbow Extension overhead

#### Muscles worked:

Triceps

#### Bench Position:

Flat Bench Back

#### Accessory:

Hand Grips

#### Adjustable Arm Position:

9

#### Success Tips

- Keep your upper arms motionless and your wrists straight.
- Keep your chest lifted and maintain spinal alignment, keeping a very slight arch in your lower back.
- Tighten the triceps throughout the exercise, using controlled motion.



#### START

- Sit on the bench facing away from the engine, keeping knees bent and feet flat on the platform.
- Reach behind and grasp one or both of the Hand Grips, using a hammer style grip.
- Draw arms up until elbows are pointing forward, hands behind head.



#### FINISH

- Keeping your upper arms stationary, straighten your elbows, bringing your hands overhead.
- Extend your elbows until your arms are completely straight, and then reverse your motion, slowly returning to the Start position without relaxing muscle tension.

## Arm Exercises

### Standing French Press – Elbow extension from a shoulder flexed position

#### Muscles worked:

Triceps. Also ankles, knees, hips, shoulders & core in stabilization.

#### Bench Position:

Removed

#### Accessory:

Long hand grips

#### Adjustable Arm Position:

8 or 9

#### Success Tips

- Stabilize body from your feet all the way up through your trunk.
- Keep knees slightly bent, feet flat on the floor and in a staggered step for stability.
- Keep abs tight, chest lifted and a slight curve in the lower back.
- Stabilize the shoulder and wrist, only allowing the elbow joint to be involved in the motion.



#### START



#### START

- Stand facing away from the engine with one foot forward and one foot back for added stability.
- Reach overhead and grasp the Hand Grips with your palms facing each other in a hammer style grip, elbows bent and pointing forward, hands behind the shoulders.
- Keep your elbows in line with the cables throughout the movement and wrists straight.

#### FINISH



#### FINISH

- Keeping the upper arms stationary, straighten your elbows, bringing your hands overhead.
- Stop your motion before your elbows are completely straight, reverse the motion, slowly returning to the Start position maintaining tension on the muscle.

### Lying Triceps Press – Elbow extension

#### Muscles worked:

Triceps

#### Bench Position:

Flat

#### Accessory:

Long hand grips

#### Adjustable Arm Position:

8 or 9

#### Success Tips

- Keep knees bent, feet on or near the floor.
- Keep abs tight, chest lifted and a slight curve in the lower back.
- Stabilize the shoulder and wrist, only allowing the elbow joint to be involved in the motion.



#### START

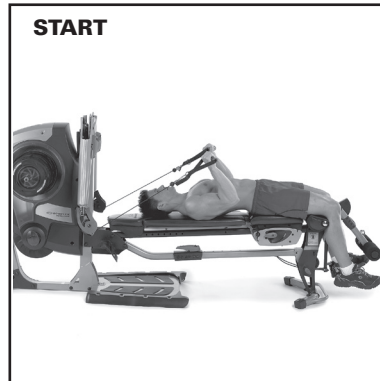

#### START

- Lie flat on the bench head toward the engine, keep knees bent, feet flat on or near the floor.
- Reach overhead and grasp the Hand Grips with your palms facing each other in a hammer style grip, elbows bent and upper arms next to your sides.
- Keep your elbows in line with the cables throughout the movement and wrists straight.

#### FINISH

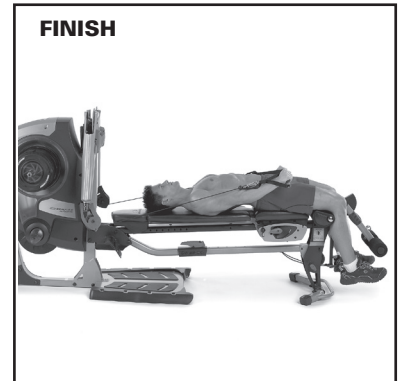

#### FINISH

- Keeping the upper arms stationary, straighten your elbows, bringing your hands down toward your sides.
- Extend your elbows completely straight, reverse the motion, slowly returning to the Start position maintaining tension on the muscle.

## Arm Exercises

### Lying 45° Triceps Extension – Elbow Extension

#### Muscles worked:

Triceps

#### Bench Position:

Flat Bench Back

#### Accessory:

Hand Grips

#### Adjustable Arm Position:

9

#### Success Tips

- Keep your upper arms motionless and your wrists straight throughout the entire exercise.
- Keep your chest lifted, spine aligned, and a slight arch in your lower back.
- Tighten the triceps throughout the exercise, using controlled motion.

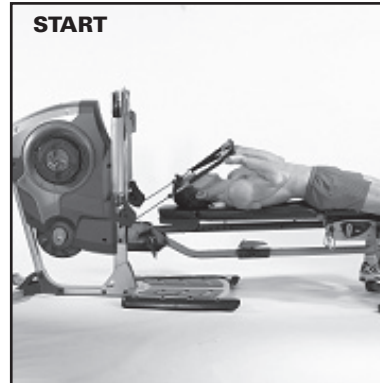

START

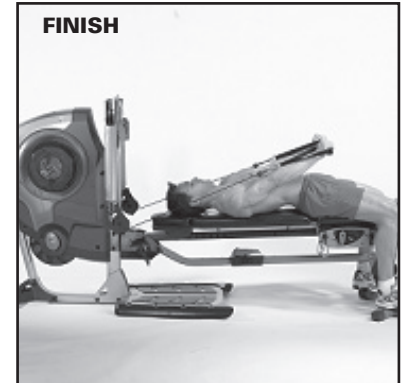

FINISH

#### START

- Lie flat on the Bench, head toward the engine. Keep your knees bent and your feet on or near the floor.
- Reach overhead and grasp the Hand Grips, palms facing up.
- Keep your elbows bent, bringing your upper arms to the front, at approximately a 45° angle from the front of your torso.

#### FINISH

- Keeping your upper arms stationary and next to your torso, straighten your arms in an arcing motion upward then down toward your legs.
- Fully straighten your arms and then, with a controlled motion, slowly bring your arms back to the Start position without moving your upper arms.

### Cross Triceps Extension

#### Muscles worked:

Triceps

#### Bench Position:

45° incline

#### Accessory:

Hand Grips

#### Adjustable Arm Position:

7 or 8

#### Success Tips

- Keep your upper arm motionless and your wrists straight.
- Keep your chest lifted, pinch your shoulder blades together and maintain a slight arch in lower back.
- Tighten the triceps throughout the exercise, using controlled motion.



START



FINISH

#### START

- Sit facing away from the engine.
- Reach one hand over the opposite shoulder (right hand over left and vice versa) and grasp a Hand Grip using a hammer style grip. Bend your elbow until your hand is above your chest.
- With your free hand, stabilize the active hand at the elbow.

#### FINISH

- Keeping your upper arm stationary, straighten your elbow, slowly extending your arm outward, using an arcing motion
- Fully extend the elbow.
- Keeping your triceps tightened, slowly reverse the arcing motion and bring your arm back to the Start position.

## Arm Exercises

### Rope Pushdowns – Elbow extension

#### Muscles worked:

Triceps

#### Bench Position:

Removed

#### Accessory:

Long hand grips

#### Adjustable Arm Position:

0 or 1

#### Success Tips

- Keep knees slightly bent, feet flat on the platform.
- Keep abs tight, chest lifted and a slight curve in the lower back.
- Stabilize the shoulder and wrist, only allowing the elbow joint to be involved in the motion.



START



FINISH

#### START

- Cross your arms and grasp the Hand Grips (right hand on left handle, left hand on right handle) palms facing slightly down with a hammer style grip.
- Bring hands toward each other, in front of you, until they are positioned as if your holding a rope.
- Keep your elbows bent, upper arms at your sides.

#### FINISH

- Keeping the upper arms stationary, straighten your elbows, bringing your hands down and back.
- Extend your elbows completely straight, reverse the motion, slowly returning to the Start position maintaining tension on the muscle.

### Standing Hammer Grip Curls – Elbow flexion neutral

#### Muscles worked:

Biceps, Brachialis, Brachioradialis

#### Bench Position:

Removed

#### Accessory:

Long hand grips

#### Adjustable Arm Position:

8 or 9

#### Success Tips

- Keep knees slightly bent, feet flat on the platform.
- Keep abs tight, chest lifted and a slight curve in the lower back.
- Stabilize the shoulder and wrist, only allowing the elbow joint to be involved in the motion.

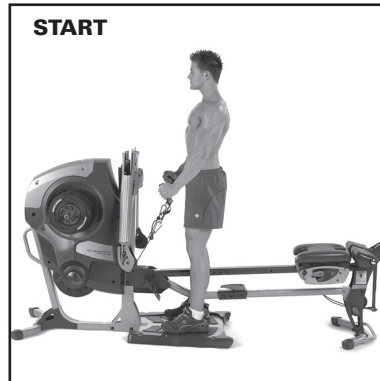

START



FINISH

#### START

- Reach down and grasp the Hand Grips with a hammer style grip.
- Press your upper arms into your sides.

#### FINISH

- Keeping the upper arms stationary and elbows at your sides, Slowly curl the handles forward then upward toward the shoulders.
- Slowly reverse the arcing motion, bringing your hands back to the Start position.

## Arm Exercises

### Standing Biceps Curl – Elbow flexion from a shoulder extended position

#### Muscles worked:

Biceps

#### Bench Position:

Removed

#### Accessory:

Long hand grips

#### Adjustable Arm Position:

8 or 9

#### Success Tips

- Stand in front of the platform facing away from the engine with a staggered step for more stability, (the back foot may be on the platform).
- Keep abs tight, chest lifted and a slight curve in the lower back.
- Stabilize the shoulder and wrist, only allowing the elbow joint to be involved in the motion.



#### START



#### START

- Reach back and grasp the Hand Grips with your arm extended backward.
- Do not let your arm go completely straight, maintain tension on the biceps.

#### FINISH



#### FINISH

- Keep the upper arms stationary and elbows back.
- Slowly curl the handles forward then upward toward the shoulders.
- Only curl forward until the cable comes close, but not touching your forearm.
- Slowly reverse the arcing motion, bringing your hands back to the Start position.

### Standing Biceps Curl – Elbow flexion from a shoulder flexed position

#### Muscles worked:

Biceps

#### Bench Position:

Removed

#### Accessory:

Long hand grips

#### Adjustable Arm Position:

2 or 3

#### Success Tips

- Stand in front of the platform facing the engine with a staggered step for more stability.
- Keep abs tight, chest lifted and a slight curve in the lower back.
- Stabilize the shoulder and wrist, only allowing the elbow joint to be involved in the motion.



#### START



#### START

- Reach up and grasp the Hand Grips with your arm extended forward.
- Do not let your arm go completely straight, maintain tension on the biceps.

#### FINISH



#### FINISH

- Keep the upper arms stationary, slowly curl the handles up then inward toward the shoulders.
- Fully shorten the biceps by squeezing the forearm toward the upper arm.
- Slowly reverse the arcing motion, bringing your hands back to the Start position.



## Arm Exercises

### Standing Biceps Curl – Elbow Flexion (in supination)

#### Muscles worked:

Biceps; Brachialis; Brachioradialis

#### Bench Position:

Removed

#### Accessory:

Hand Grips

#### Adjustable Arm Position:

8, 9

#### Success Tips

- Keep your chest lifted, abs tight and a very slight arch in your lower back.
- Keep your elbows at your sides and your wrists straight.



**START**



**FINISH**

#### START

- Straddle the Seat Rail, facing the engine.
- Reach down and grasp the Hand Grips, palms facing forward.
- Straighten, with your arms slightly bent, keeping tension on the biceps.

#### FINISH

- Keeping your upper arms stationary and your elbows at your sides, slowly curl the Hand Grips forward, then upward and in towards your shoulders.
- Slowly reverse the arcing motion bringing your hands back to the Start position.

### Seated Biceps Curl – Flexion (in supination)

#### Muscles worked:

Bicep; Brachialis; Brachioradialis

#### Bench Position:

Flat Bench Back

#### Accessory:

Hand Grips

#### Adjustable Arm Position:

8

#### Success Tips

- Keep your upper body motionless and your wrists straight.
- Keep your chest lifted, trunk muscles tight and maintain a slight arch in lower back.
- Keep your spine aligned throughout movement

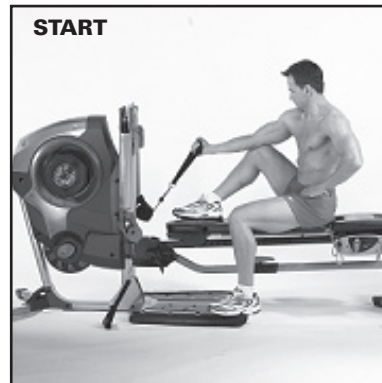

**START**



**FINISH**

#### START

- Sit on the bench, facing the engine. Keep one foot flat on the floor, and bend the other leg, bringing your foot up onto the bench, knee slightly turned outward.
- With the arm on the same side as your lifted leg, reach forward and grasp a Hand Grip, keeping your elbow bent. Allow your upper arm (not elbow) to rest on the elevated knee.

#### FINISH

- Slowly curl your forearm up toward your shoulder, keeping the upper arm completely still.
- Keeping your biceps tightened, slowly reverse the curling motion and bring your arm back to the Start position.

## Arm Exercises

### Preacher Curl – Elbow Flexion (in supination)

#### Muscles worked:

Biceps; Brachialis; Brachioradialis

#### Bench Position:

Seat

#### Accessory:

Preacher Curl Attachment, Curl Bar; Leg Press Seat Back (optional)

#### Adjustable Arm Position:

9

#### Success Tips

- Keep wrists straight.
- Keep chest lifted, abs tight and maintain a very slight arch in your lower back.
- For additional stability, rest your back against the Leg Press Seat Back.



START



START

- Sit at the end of the bench facing away from the engine.
- Rest your elbows on the platform and grasp the inner handles of the ab/leg attachment with an underhand grip.
- Your knees should be bent and feet flat on the floor.
- Keep tension on the muscle and do not let the arm go straight.

FINISH



FINISH

- Slowly curl the handles in an arc toward your head while keeping your elbows and upper arms completely still.
- Slowly lower to the Start position.

For information on how to attach the Preacher Curl Attachment and cables, and Leg Press Seat Back, please see the earlier section in this manual (or the corresponding section in the Assembly Manual) on how to install attachments.

### Reverse Grip Tricep Pushdown

#### Muscles worked:

Triceps

#### Bench Position:

Removed

#### Accessory:

Short Hand Grips

#### Adjustable Arm Position:

8

#### Success Tips

- Keep your upper arms motionless
- Keep your wrists straight.
- Tighten your triceps throughout the exercise and control the motion on the way back.



START



START

- Stand on the platform facing the engine.
- Grasp the short hand grips with an underhand grip at shoulder width.
- Bring your arms straight down to your sides.

FINISH

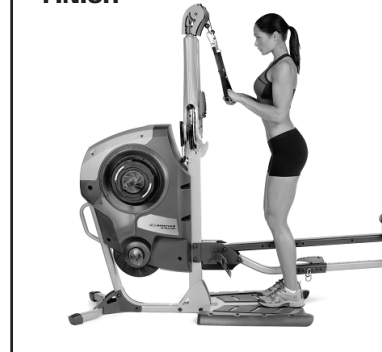

FINISH

- Keeping your upper arms stationary, elbows in a fixed position, bend your elbows moving your hands in an arcing motion towards your shoulders.
- Stop your motion when your hands are above your elbows, then slowly reverse your arcing motion until your elbows are straight.

# Arm Exercises

## Tricep Kickback

### Muscles worked:

Triceps

### Bench Position:

Flat Back Bench

### Accessory:

Hand Grips

### Adjustable Arm Position:

8 or 9

### Success Tips

- Maintain good spinal alignment.
- Keep your arm at your side and your wrist straight throughout entire motion.
- Tighten the triceps throughout the exercise and control the returning motion.



START



FINISH

### START

- Straddle the bench facing the engine, bend forward at your hips until your torso is parallel to the bench, slightly arching your back.
- Support yourself with one arm on the bench and grasp a handle using a hammer style grip with your free hand.
- Draw your elbow back so that the upper arm is by your side, parallel to the bench, and your elbow bent about 90°.

### FINISH

- Completely straighten your elbow while keeping your upper arm completely still.
- Slowly return to the Start position.
- Repeat with the other arm on the other side of the machine after completing a set.

## Reverse Curl – Elbow Flexion (in pronation)

### Muscles worked:

Brachialis; Brachioradialis; Biceps

### Bench Position:

Removed

### Accessory:

Hand Grips

### Adjustable Arm Position:

8, 9

### Success Tips

- Keep your upper body motionless, elbows at your sides and your wrists straight.
- Keep your trunk muscles tight and maintain a slight arch in lower back.



START



FINISH

### START

- Straddle the Seat Rail, facing the engine.
- Reach down and grasp the Hand Grips, palms facing backward.
- Straighten, keeping your upper arms and elbows by your sides.
- Keep tension on the muscle and do not fully extend the elbow.

### FINISH

- Keeping your palms facing down, use your forearms to slowly bend your elbows, curling the Hand Grips forward, then upward and in towards your shoulders.
- Keep your elbows at your sides and your upper arms completely still.
- Slowly reverse the curling motion and bring your arms back to Start position.

## Arm Exercises

### Lying Biceps Curl – Elbow Flexion (in supination)

#### Muscles worked:

Biceps; Brachialis; Brachioradialis

#### Bench Position:

Flat Bench Forward

#### Accessory:

Hand Grips

#### Adjustable Arm Position:

8

#### Success Tips

- Keep your upper arms motionless and your wrists straight throughout the entire exercise.
- Keep your chest lifted, spine straight, and a slight arch in your lower back.

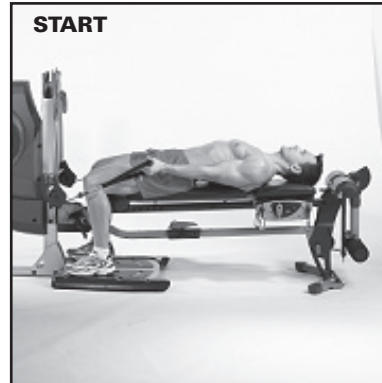

START

#### START

- Sit on the bench, facing the engine. Keep your knees bent and feet flat on the platform.
- Grasp the Hand Grips with your palms up and arms slightly bent, keeping tension on the muscle.
- Lie back completely with your head supported by the bench.



FINISH

#### FINISH

- Curl the Hand Grip forward and up, toward your shoulder, making sure to keep your upper arm completely motionless and your elbows at your sides.
- Slowly bring your arm back to the Start position, maintaining the same arc of motion.

### Seated Wrist Extension

#### Muscles worked:

Extensor Carpi Ulnaris;  
Extensor Digitorum

#### Bench Position:

Flat Bench Back

#### Accessory:

Hand Grips

#### Adjustable Arm Position:

9

#### Success Tips

- Move slowly and keep tension in the back of the forearms at all times.
- Keep your chest lifted, trunk muscles tightened, and a very slight arch in your lower back.
- You may perform this exercise one arm at a time to make it easier to focus and isolate the back of your forearms, or with both arms simultaneously to save time.



START

#### START

- Sit facing the engine with your knees bent, feet together and flat on the bench. Sit far back enough on the bench to maintain muscle and cable tension throughout exercise.
- Grasp the Hand Grips, palm facing down, and rest your mid-forearms on your lower thighs, keeping your elbows flared slightly to the sides.



FINISH

#### FINISH

- Slowly curl the back of your fists backward towards your forearms.
- Move the wrist to full extension.
- Slowly return to the Start position.

## Arm Exercises

### Standing Wrist Curls – Wrist flexion from elbow flexed position

#### Muscles worked:

Biceps, Flexor Digitorum, Flexor Carpi Radialis

#### Bench Position:

Removed

#### Accessory:

Long hand grips

#### Adjustable Arm Position:

8 or 9

#### Success Tips

- Stand on the platform facing the engine.
- Keep abs tight, chest lifted and a slight curve in the lower back.
- Stabilize the shoulder and elbow, only allowing the wrist joint to be involved in the motion.



START



FINISH

#### START

- Reach down and grasp the Hand Grips, palms facing up, then position your upper arms against your sides.
- Bend your elbow to approximately 90° and keep it there throughout the exercise.

#### FINISH

- Keep the shoulder and elbow stationary, slowly curl your fists up then inward toward the forearms.
- Slowly reverse the arcing motion, bringing your hands back to the Start position.

### Standing Wrist Extension – Wrist extension from an elbow flexed position

#### Muscles worked:

Extensor Digitorum, Extensor Carpi Ulnaris

#### Bench Position:

Removed

#### Accessory:

Long hand grips

#### Adjustable Arm Position:

8 or 9

#### Success Tips

- Stand on the platform facing the engine.
- Keep abs tight, chest lifted and a slight curve in the lower back.
- Stabilize the shoulder and elbow, only allowing the wrist joint to be involved in the motion.



START



FINISH

#### START

- Reach down and grasp the Hand Grips, palms facing down, then position your upper arms against your sides.
- Bend your elbow to approximately 90° and keep it there throughout the exercise.

#### FINISH

- Keep the shoulder and elbow stationary, slowly curl your fists up then inward toward the forearms.
- Slowly reverse the arcing motion, bringing your hands back to the Start position.

## Arm Exercises

### Seated Wrist Curl – Wrist Flexion

#### Muscles worked:

Flexor Digitorum;  
Flexor Carpi Radialis

#### Bench Position:

Flat Bench Back

#### Accessory:

Hand Grips

#### Adjustable Arm Position:

9

#### Success Tips

- Move slowly, keeping tension in the front of the forearms at all times.
- Keep your chest lifted, trunk muscles tightened, and a slight arch in your lower back.
- You can perform this exercise one arm at a time to make it easier to focus and isolate the front of your forearms, or you can perform it with both arms simultaneously to save time.



**START**

#### START

- Sit facing the engine with your knees bent, feet together and flat on the bench. Sit far back enough on the bench to maintain muscle and cable tension throughout exercise.
- Grasp the Hand Grips, palm facing up, and rest your mid-forearms on your lower thighs, allowing the wrists to bend downward.



**FINISH**

#### FINISH

- Slowly curl your fists towards the front of your forearms.
- Return to the Start position slowly, without relaxing the muscle tension in your wrists.

# Abdominal Exercises

## Standing Trunk Rotation

### Muscles worked:

Rectus Abdominus, Obliques, Spinal Erectors and Serratus Anterior

### Bench Position:

Removed

### Accessory:

Long hand grips

### Adjustable Arm Position:

4 or 5

### Success Tips

- Keep your knees slightly bent and feet flat on the floor.
- This exercise must be performed correctly, failure to do so could result in injury (use a light resistance).
- Keep all motion in your torso.
- Move only as far as your muscles will take you. Do not use momentum to increase your range of motion.



### START



### START

- Stand with one side toward the engine, angled about 45° away from the platform.
- Grab the handle closest to you with both hands.
- Raise your arms up near shoulder height, arms extended toward the leg closest to the engine.
- Keep the elbows slightly bent.

### FINISH



### FINISH

- Tighten the entire abdominal area and slowly rotate your rib cage and arms away from the engine 30-40 degrees, as if you were rotating with a rod through the middle of your spine.
- Slowly reverse the motion, returning to the Start position without losing muscle tension.

## Standing Oblique Crunch

### Muscles worked:

Rectus Abdominus, Obliques

### Bench Position:

Removed

### Accessory:

Long hand grips

### Adjustable Arm Position:

0 or 1

### Success Tips

- Keep your knees slightly bent and feet flat on the platform.
- This exercise must be performed correctly, failure to do so could result in injury (use a light resistance).
- Keep all motion in your torso.
- Move only as far as your muscles will take you. Do not use momentum to increase your range of motion.



### START



### START

- Stand on one side, straddling the seat rail, facing away from the engine.
- Grasp one Hand Grip, reaching over the opposite shoulder, and position the webbing over the shoulder as shown.

### FINISH

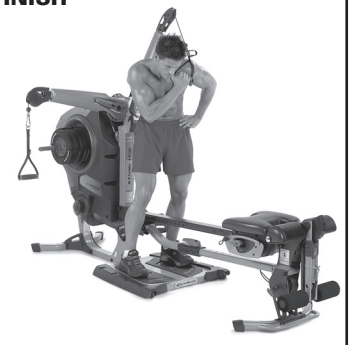

### FINISH

- Tighten your ab muscles on the side with the active arm, focusing on the side of your ribs toward the front of your pelvis.
- Slowly move diagonally, rotating your torso away from the side holding the hand grip.
- Crunch as deeply as you can, keeping the hips stable. Do not lean forward at the hips.
- Slowly reverse the motion, returning to the Start position without losing muscle tension.

## Abdominal Exercises

### Kneeling "Wood Chop" – High to Low Trunk flexion with rotation

#### Muscles worked:

Rectus Abdominus, Obliques, and Serratus Anterior



#### Bench Position:

Removed

#### Accessory:

Long hand grips

#### Adjustable Arm Position:

0 or 1

#### Success Tips

- This exercise must be performed correctly, failure to do so could result in injury (use a light resistance).
- Keep all motion in your torso.
- Move only as far as your muscles will take you. Do not use momentum to increase your range of motion.

#### START



#### START

- Stand off to one side of the platform and kneel down on the knee closest to the engine angled about 45° away from the platform.
- Raise your arms above your head and grab the handle closest to you with both hands.
- Arms extended toward the pulley.
- Keep the elbows slightly bent.

#### FINISH



#### FINISH

- Tighten the entire abdominal area and slowly rotate your rib cage and arms away from the pulley toward your opposite knee.
- Slowly reverse the motion, returning to the Start position without losing muscle tension.

### Kneeling Low to High Trunk Rotation

#### Muscles worked:

Rectus Abdominus, Obliques, Spinal Erectors and Serratus Anterior



#### Bench Position:

Removed

#### Accessory:

Long hand grips

#### Adjustable Arm Position:

9

#### Success Tips

- This exercise must be performed correctly, failure to do so could result in injury (use a light resistance).
- Keep all motion in your torso.
- Move only as far as your muscles will take you. Do not use momentum to increase your range of motion.

#### START



#### START

- Stand off to one side of the platform and kneel down on the knee closest to the engine angled about 45° away from the platform.
- Reach across and down, grab the handle closest to you with both hands.
- Arms extended toward the pulley.
- Keep the elbows slightly bent.

#### FINISH



#### FINISH

- Tighten the entire abdominal area and slowly rotate your rib cage and arms up and away from the pulley toward your opposite knee and slightly above your head.
- Slowly reverse the motion, returning to the Start position without losing muscle tension.



# Abdominal Exercises

## Reverse Crunch – Spinal Flexion

### Muscles worked:

Rectus Abdominus; Obliques

### Bench Position:

Flat Bench Back

### Accessory:

None

### Adjustable Arm Position:

None

### Success Tips

- Keep your upper body, knees and hips stationary. Relax your neck.
- Tighten your abs before you move.
- Allow exhalation up and inhalation down without exaggerating breathing.
- Contract as far into the movement as possible. Lower under control. Keep abs tight during entire motion.



START



FINISH

### START

- Lie on the bench, head toward the engine, grasp bench for support.
- Bend your hips and knees until your legs are in a “seated” position as shown above—knees and hips at 90° angles.
- If maintaining this position is difficult, move your knees toward your chest and maintain that position for the duration of this exercise. As you strengthen, this position will become easier.

### FINISH

- Tighten your abs, and then slowly curly your hips toward your rib cage. Move as far as you can without using your legs to get momentum.
- Do not curl up onto your shoulder blades.
- Slowly reverse the motion, returning to the Start position without relaxing.

## Trunk Rotation

### Muscles worked:

Rectus Abdominus; Obliques;  
Transverse Abdominus

### Bench Position:

Flat Bench Back

### Accessory:

Handgrips

### Adjustable Arm Position:

5 or 6

### Success Tips

- Keep chest lifted, shoulders pinched, abs tight and slight arch in lower back.
- This exercise must be performed correctly—failure to do so could result in injury. Use only low resistance.
- Keep all motion in your torso.
- Move only as far as your muscles will take you—do not use momentum to increase your range of motion



START



FINISH

### START

- Sit sideways on the bench, one side toward the engine. Grasp Hand Grip closest to you with both hands.
- Raise both arms up near shoulder level, hands extended over the leg closest to the engine.
- Keep your elbows slightly bent.

### FINISH

- Tighten your entire abdominal area and slowly rotate your rib cage and arms away from the engine 30-40°, as if you were rotating with a rod through the middle of your spine.
- Slowly reverse the motion, returning to the Start position without relaxing muscle tension.

## Abdominal Exercises

### Seated (Resisted) Abdominal Crunch – Spinal Flexion

#### Muscles worked:

Rectus Abdominus; Obliques

#### Bench Position:

45° incline

#### Accessory:

Hand Grips

#### Adjustable Arm Position:

8

#### Success Tips

- Do not lift your head or chin—your head should follow the rib motion rather than lead it. Maintain normal neck posture.
- Tighten your abs throughout the entire exercise, relaxing only at the end of each set.
- Move slowly to eliminate momentum.
- Allow exhalation down and inhalation up without exaggerating breathing.



START

#### START

- Grasp the Hand Grips in both hands, drawing them over your shoulders. Rest the back of your fists on your chest or shoulders, palms facing up.
- Lower back can start out flat or in a normal arch, knees and hips are bent and feet should be flat on the floor.



FINISH

#### FINISH

- Tighten your abs and curl only your torso, slowly moving your ribs toward your hips. Move as far as you can without moving your hips or neck.
- Do not allow your lower back to lose contact with the bench during this entire exercise.
- Slowly reverse the motion, returning to the Start position without relaxing your abs.

### Seated (Resisted) Oblique Abdominal Crunch – Spinal Oblique Flexion

#### Muscles worked:

Rectus Abdominus; Obliques

#### Bench Position:

45° incline

#### Accessory:

Hand Grips

#### Adjustable Arm Position:

7

#### Success Tips

- Do not lift your head or chin—your head should follow the rib motion rather than lead it. Maintain normal neck posture.
- Tighten your abs throughout the entire exercise, relaxing only at the end of each set.
- Move slowly to eliminate momentum.
- Allow exhalation down and inhalation up without exaggerating breathing.



START

#### START

- Cross one arm over the opposite shoulder, grasp a Hand Grip, and rest the hand on your shoulder or chest, palm facing down.
- Lower back can start out flat or in a normal arch, knees and hips are bent and feet should be flat on the floor.



FINISH

#### FINISH

- Tighten your abs on the side with the active arm, focusing on the side of your ribs to the front of your pelvis on that side.
- Slowly move diagonally, rotating torso away from the side holding the Hand Grip, ribs turned toward the front of your pelvis.
- Crunch as deeply as you can, keeping lower back on bench.
- Slowly reverse to the Start position without resting.

# Leg Exercises

## Leg Extension

### Muscles worked:

Quadriceps

### Bench Position:

Leg Extension Seat

### Accessory:

Leg Extension (refer to instructions for hooking up the cables for leg exercises); Leg Press Seat Back (optional)

### Adjustable Arm Position:

9



START



FINISH

### Success Tips

- Use slow, controlled motion—do not “kick” into the extension.
- Do not let your knees rotate outward during the exercise. Keep kneecaps pointing up and straight forward.
- For additional stability, rest your back against the Leg Press Seat Back. (Refer to instructions for attaching the Leg Press Seat Back accessory.)

### START

- Sit on the Leg Extension Seat with your knees near the pivot point and the lower roller pads in front of your shins (see Start image above).
- Adjust your thighs to hip-width, pointing your knee caps forward.
- Grasp the sides of the seat to stabilize yourself.
- Sit up straight, chest lifted, abs tight and a slight arch in your lower back.

### FINISH

- Tighten your quads and slowly straighten your legs, moving your feet forward then upward until your legs are completely straight and your kneecaps point upward to the ceiling.
- Slowly reverse the motion, returning to the Start position without relaxing your quads.

## Prone (Lying face down) Leg Curls

### Muscles worked:

Hamstrings

### Bench Position:

Flat with leg curl attachment

### Accessory:

Leg Extension (Refer to instructions for hooking up the cables for leg exercises.)

### Adjustable Arm Position:

9



START



FINISH

### Success Tips

- Make sure you straighten your legs under control; do not allow your knees to hyper-extend.
- Keep the chest lifted, abs tight and maintain a very slight arch in the lower back.
- Try to relax the calf and foot muscles focusing on the hamstrings.

### START

- Set up the leg curl attachment with the bar up as shown, and the bench flat.
- Lie face down on the bench with your lower thighs on the pad, the knees near the pivot point and the ankles under the foam roller pads.
- Point your knees straight down and tighten your inner thigh muscles (as if you are squeezing them together) to stabilize.
- Place your hands on the bench for stability and your forehead on the bench or turned to the side. Do not look up hyper-extending your neck.
- Tighten your abs to prevent spinal motion and very slightly lift your thighs off the pad.

### FINISH

- Slowly bend your knees, upward and then toward your hips without moving your spine and without lifting your hips from the bench.
- Keep the hamstring tight. Slowly straighten the legs, returning to the Start position without losing muscle tension.
- Do not allow them to fully straighten or lock out.

## Leg Exercises

### Lying Leg Extension

**Muscles worked:**

Quadriceps

**Bench Position:**

Flat

**Accessory:**

Foot harness

**Adjustable Arm Position:**

9

**Success Tips**

- Keep your hip and upper thigh motionless throughout the exercise.
- Lift your chest, keep your abs tight and maintain a very slight arch in your low back.

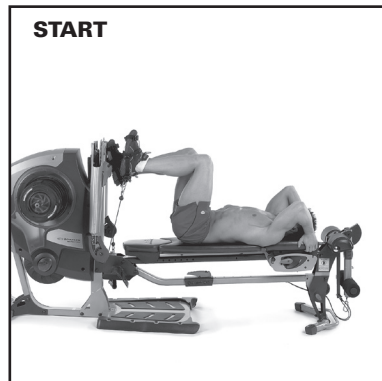

**START**



**FINISH**

**START**

- While sitting on the bench facing the engine, attach one cable to the D-ring on the heel of the foot harness.
- Lie on the bench with your hip flexed and knee bent to approximately 90°.
- Tall users may have to modify this position.
- Feet, ankles and knees should be in line with the cables.

**FINISH**

- Without moving your hips, slowly extend your leg, moving only your knee and lower leg.
- Slowly reverse the motion, returning to the Start position without losing muscle tension.

### Standing Hip Flexion w/ Knee Flexion

**Muscles worked:**

Iliacus, Psoas, Rectus Femoris

**Bench Position:**

Removed

**Accessory:**

Foot harness

**Adjustable Arm Position:**

9

**Success Tips**

- Make sure all the motion is occurring at your hip and the knee.
- Keep the torso tight throughout the motion.

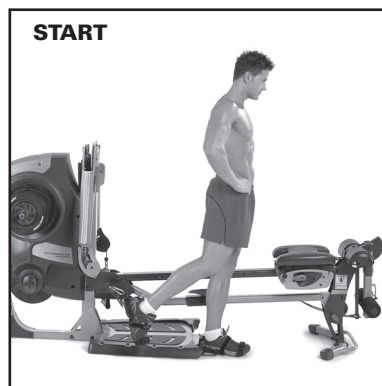

**START**

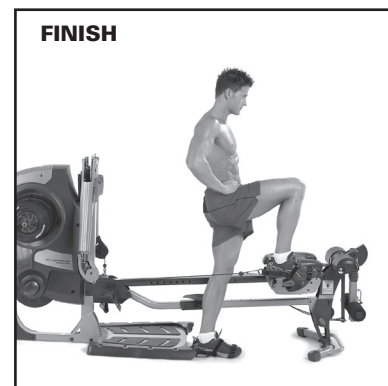

**FINISH**

**START**

- Stand on the platform on one side of the seat rail facing away from the engine.
- Attach one cable to the D-ring on the heel of the foot harness.
- Straighten but do not lock out the support leg.
- Stand far enough away from the pulley so that there is tension at the start of the motion.

**FINISH**

- Initiate the movement by lifting your knee up toward your torso, allowing your knee to bend without allowing any movement in your waist or lower back.
- After lifting your knee as high as possible, return to the Start position. Repeat with the other leg.

## Leg Exercises

### Standing Leg Kickback – Hip and Knee Extension

#### Muscles worked:

Gluteus Maximus; Hamstring muscles

#### Bench Position:

Removed

#### Accessory:

Foot Harness

#### Adjustable Arm Position:

9

#### Success Tips

- Keep your chest lifted, spine aligned, abs tight and a very slight arch in your lower back.
- Do not bend from waist or lower back.



START

#### START

- Stand to one side of the Seat Rail, facing the engine.
- Secure the Foot Harness around the ankle furthest from the rail. Bend this leg approximately 90°.
- Bend forward 30-40° from your hips (not your waist) and very slightly bend the knee of your supporting leg.



FINISH

#### FINISH

- Extend the active leg backwards, straightening the knee.
- Slowly move your leg as far as you can, without allowing any movement at the waist, knee or lower back.
- Slowly return to the Start position.

### Standing Hip Extension – (knee flexed)

#### Muscles worked:

Gluteus Maximus; Hamstring muscles

#### Bench Position:

Removed

#### Accessory:

Foot Harness

#### Adjustable Arm Position:

9

#### Success Tips

- Keep your chest lifted, spine aligned, abs tight and a very slight arch in your lower back.
- Do not bend from waist or lower back.
- Keep tension on the cable. Do not let the ball on the cable rest against the pulley.



START

#### START

- Stand to one side of the Seat Rail, facing the engine.
- Secure the Foot Harness around the foot furthest from the rail. Bend this leg approximately 90°.
- Bend forward 30-40° from your hips (not your waist) and very slightly bend the knee of your supporting leg.



FINISH

#### FINISH

- Initiate the movement by tightening your glutes and hamstrings. Slowly pivot your leg from your hip. Move your entire leg backward, to a straight position.
- Slowly move your leg as far as you can, without allowing any movement at the waist or lower back.
- Slowly return to Start position.

## Leg Exercises

### Ankle Eversion

#### Muscles worked:

Peroneals

#### Bench Position:

Flat Bench Forward

#### Accessory:

Foot Harness

#### Adjustable Arm Position:

8

#### Success Tips

- Movement should occur only at the ankle—keep the rest of your body motionless.
- Keep abs tight and do not lift your hips or excessively arch your back.
- You should feel tension in the outside of your calf throughout the entire motion



START



FINISH

#### START

- Sit on the Bench, with one side to the engine.
- Attach a Foot Harness on the foot farthest from the pulley. Snap on the top ring to the cable.
- Straighten the attached leg and sit up straight.
- Allow the foot to rotate toward the engine, keeping tension in the cables.

#### FINISH

- Slowly rotate your foot outward, away from engine.
- Then, maintaining tension, slowly return to the Start position.

### Ankle Inversion

#### Muscles worked:

Tibialis Anterior and Posterior

#### Bench Position:

Flat Bench Forward

#### Accessory:

Foot Harness

#### Adjustable Arm Position:

8

#### Success Tips

- Movement should occur only at the ankle—keep the rest of your body motionless.
- Keep abs tight and do not lift your hips or excessively arch your back.
- You should feel tension in the inside of your calf throughout the entire motion



START



FINISH

#### START

- Sit on the Bench, with one side to the engine.
- Attach a Foot Harness on the foot closest to pulley.
- Straighten the attached leg and sit up straight.
- Allow the foot to rotate toward the engine, keeping tension in the cables.

#### FINISH

- Slowly rotate your foot inward, away from engine.
- Then, maintaining tension, slowly return to the Start position.

# Leg Exercises

## Hip Abduction

### Muscles worked:

Gluteus Minimus; Gluteus Medius; Tensor Fasciae Latae

### Bench Position:

Not used

### Accessory:

Foot Harness

### Adjustable Arm Position:

8

### Success Tips

- Keep your chest lifted, spine aligned, abs tight and a slight arch in your lower back.
- Do not bend from waist or lower back.
- Keep your abs tight throughout movement.
- Keep working leg straight or only very slightly bent.
- Use only a small range of motion.

### VARIATIONS

You can perform hip abduction exercises from a seated position, as well.



START



FINISH

### START

- Stand to one side of the Seat Rail, one side next to engine.
- Secure Foot Harness on the foot furthest from the engine. Keep leg slightly bent.
- Adjust your position so that there is some tension in the cables at the start of this exercise.
- You may use your hand on the swing arm to stabilize movement.

### FINISH

- Slowly move the attached leg outward, away from the engine, at a 30-45° angle, keeping your hips and spine motionless.
- Slowly return to the Start position without relaxing tension in your leg.
- Keep your hips level during movement.

## Hip Adduction

### Muscles worked:

Adductors; Gluteus Medius

### Bench Position:

Not used

### Accessory:

Foot Harness

### Adjustable Arm Position:

8

### Success Tips

- Keep your chest lifted, spine aligned, abs tight and a slight arch in your lower back.
- Do not bend from waist or lower back.
- Keep your abs tight throughout movement.
- Keep working leg straight or only very slightly bent.
- Use only a small range of motion.

### VARIATIONS

You can perform hip adduction exercises from a seated position, as well.



START



FINISH

### START

- Stand to one side of the Seat Rail, one side next to engine.
- Secure Foot Harness on the foot closest to the engine. Keep leg slightly bent.
- Adjust your position so that there is some tension in the cables at the start of this exercise.
- You may use your hand on the swing arm to stabilize movement.

### FINISH

- Slowly move the attached leg inward, away from the engine, at a 30-45° angle, keeping your hips and spine motionless.
- Slowly return to the Start position without relaxing tension in your leg.
- Keep your hips level during movement.

## Leg Exercises

### Standing Hip Flexion

#### Muscles worked:

Iliacus, Psoas, Rectus Femoris

#### Bench Position:

Removed

#### Accessory:

Foot harness

#### Adjustable Arm Position:

9

#### Success Tips

- Make sure all the motion is occurring at your hip.
- Keep the torso tight throughout the motion.



START

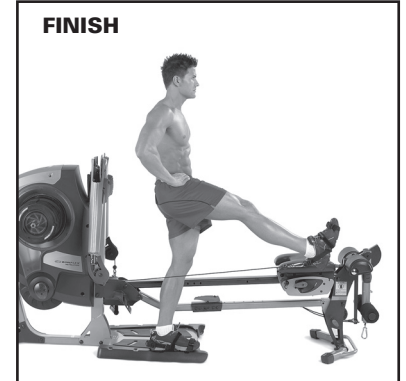

FINISH

#### START

- Stand on the platform on one side of the seat rail facing away from the engine.
- Attach one cable to the D-ring on the heel of the foot harness.
- Straighten but do not lock out the support leg.
- Stand far enough away from the pulley so that there is tension at the start of the motion.

#### FINISH

- Initiate the movement by moving your whole leg forward, without allowing any movement in your waist or lower back.
- After moving your leg as far as possible, return to the Start position. Repeat with the other leg.

### Standing Hip Internal Rotation

#### Muscles worked:

Gracilis, Adductor Magnus

#### Bench Position:

Removed

#### Accessory:

Foot harness

#### Adjustable Arm Position:

9

#### Success Tips

- Make sure all the motion is occurring at your hip.
- Keep the torso tight throughout the motion.

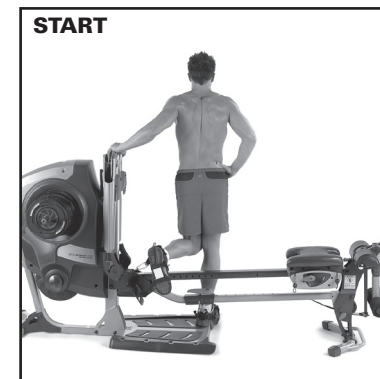

START

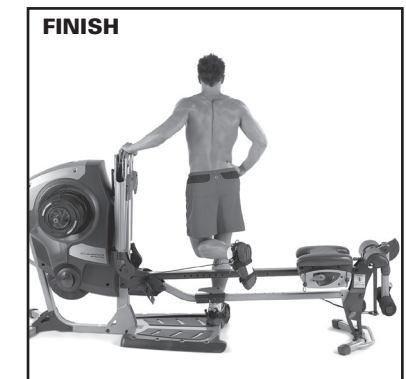

FINISH

#### START

- Stand on the platform on one side of the seat rail facing sideways from the engine.
- Attach one cable to the D-ring on the foot closest to the pulley on the outside edge near the front of your foot.
- Straighten but do not lock out the support leg.
- Stand far enough away from the pulley so that there is tension at the start of the motion.

#### FINISH

- Initiate the movement by moving your whole leg by rotating at the hip, without allowing any movement in your waist or lower back.
- After rotating your leg as far as possible, return to the Start position.
- Repeat with the other leg.



# Leg Exercises

## Standing Hip External Rotation

### Muscles worked:

Glute medius posterior fibers, Piriformis and other deep rotators

### Bench Position:

Removed

### Accessory:

Foot harness

### Adjustable Arm Position:

9

### Success Tips

- Make sure all the motion is occurring at your hip.
- Keep the torso tight throughout the motion.

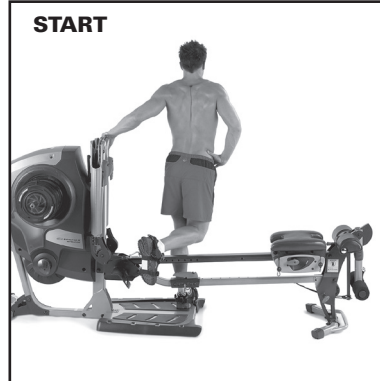

START



FINISH

### START

- Stand on the platform on one side of the seat rail facing sideways from the engine.
- Attach one cable to the D-ring on the outside foot near the front inside edge.
- Straighten but do not lock out the support leg.
- Stand far enough away from the pulley so that there is tension at the start of the motion.

### FINISH

- Initiate the movement by moving your whole leg by rotating at the hip, without allowing any movement in your waist or lower back.
- After rotating your leg as far as possible, return to the Start position.
- Repeat with the other leg.

## Lying Hip Internal Rotation

### Muscles worked:

Tensor Facia late, Piriformis, Glute medius anterior fibers

### Bench Position:

Removed

### Accessory:

Foot harness

### Adjustable Arm Position:

9

### Success Tips

- Make sure all the motion is occurring at your hip.
- Keep the torso tight throughout the motion.

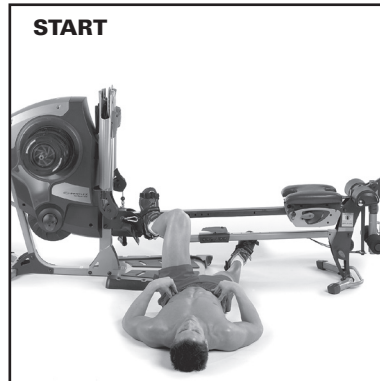

START

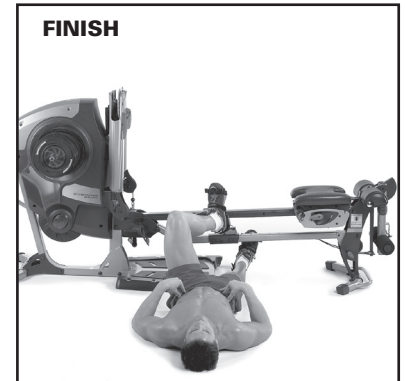

FINISH

### START

- Attach one cable to the D-ring on the foot closest to the pulley on the outside edge near the front of your foot.
- Lie on your back with your hip and knee flexed to 90°.
- Position yourself so the cable is pulling at a 90 degree angle off the foot harness.
- Lie far enough away from the pulley so that there is tension at the start of the motion.

### FINISH

- Initiate the movement by moving your whole leg by rotating at the hip, without allowing any movement in your waist or lower back.
- After rotating your leg as far as possible, return to the Start position.
- Repeat with the other leg.

## Leg Exercises

### Leg Press

#### Muscles worked:

Quadriceps

#### Bench Position:

Removed

#### Accessory:

Sliding seat; Leg Press Plate

#### Adjustable Arm Position:

9

#### Success Tips

- Keep your spine in good posture.
- Straighten but do not lock your knees.
- Keep your quads tightened throughout the entire motion.
- Do not use momentum, **MOVE SLOWLY**.
- Lift your chest, tighten your abs and maintain a very slight arch in your lower back.



START

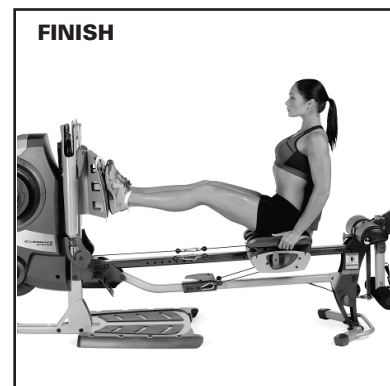

FINISH

#### START

- Remove the bench and unlock the rowing seat. (Refer to instructions for hooking up the cables for Leg Press exercises.)
- Sit facing the engine, your feet on the leg press plate.
- Bend your knees and hips slowly allowing yourself to slide toward the engine.
- Rest your hands in a comfortable position.

#### FINISH

- Straighten your legs, but do not lock your knees.
- Limit your slide to a position that allows you to still maintain good spinal posture, with your chest lifted, abs tight and a slight arch in your lower back.
- Slowly return to the Start position.

## VARIATION

### Single Leg - Leg Press – Knee Extension w/ hip extension

#### Muscles worked:

Quadriceps

#### Bench Position:

Sliding seat; Leg Press Plate

#### Accessory:

Foot Plate; Leg Press Seat Back

#### Adjustable Arm Position:

9

#### Success Tips

- Keep your spine in good posture.
- Tighten, but do not lock your knees.
- Keep your quads tight through the entire motion.
- Move slowly and under control.
- Lift your chest, keep your abs tight and maintain a very slight arch in your low back.

#### START

- Remove the bench and set up the machine with the sliding seat, back support pad and leg press plate. (Refer to instructions for hooking up the cables for Leg Press exercises.)
- Sit facing the engine with your foot on the foot plate positioned comfortably for you to press with one leg at a time.
- Bend your knees and hips allowing yourself to slide toward the engine.
- Limit this Start position that still allows you to maintain good posture and from flexing your knee past 90°.

#### FINISH

- Straighten your leg by pressing through your heel without taking your front foot off the plate. Move to a straightened position without locking out your knees.
- Slowly reverse the motion, returning to the Start position without losing muscle tension.

# Leg Exercises

## Calf Raise

### Muscles worked:

Gastrocnemius; Soleus

### Bench Position:

Removed

### Accessory:

Sliding seat; Foot Harness; Leg Press Plate

### Adjustable Arm Position:

8

### Success Tips

- Keep your chest lifted, spine aligned, abs tight and a slight arch in your lower back.
- Do not bend from waist or lower back.
- Keep your abs tight throughout movement.
- Keep legs straight or only very slightly bent.
- Use only a small range of motion.

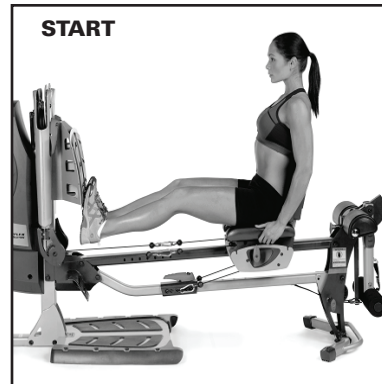

START



FINISH

### START

- Remove the bench and unlock the rowing seat. (Refer to instructions for hooking up the cables for Leg Press exercises.)
- Sit on the seat facing the engine.
- Place the balls of your feet on the Leg Press Plate.
- Push back and straighten your legs, but do not lock your knees.

### FINISH

- Slowly press the balls of your feet into the frame and pull your heels towards your knees
- Slowly return to the Start position without relaxing.

## Dorsi Flexion

### Muscles worked:

Tibia Dorsi

### Bench Position:

Removed

### Accessory:

Sliding seat; Foot Harness

### Adjustable Arm Position:

9

### Success Tips

- Move only at the ankle.
- Move your toe as far forward as possible, but don't let the handle slip off.



START

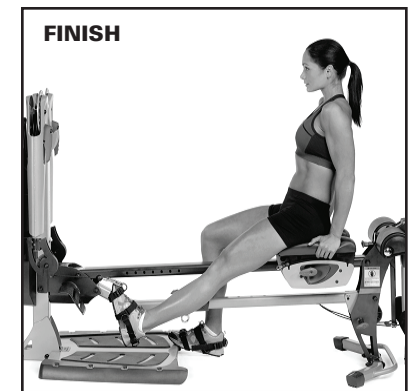

FINISH

### START

- Sit on the bench facing toward the engine.
- Attach the Foot Harness on your right foot, bend your knee, place your heel on the bench, and sit upright so that there is tension on the cable.
- Your left foot should be flat on the platform, hands on your waist.

### FINISH

- Slowly pull the top of your foot toward you.
- Slowly return to the Start position.
- Repeat with the left ankle.

# Muscle Chart

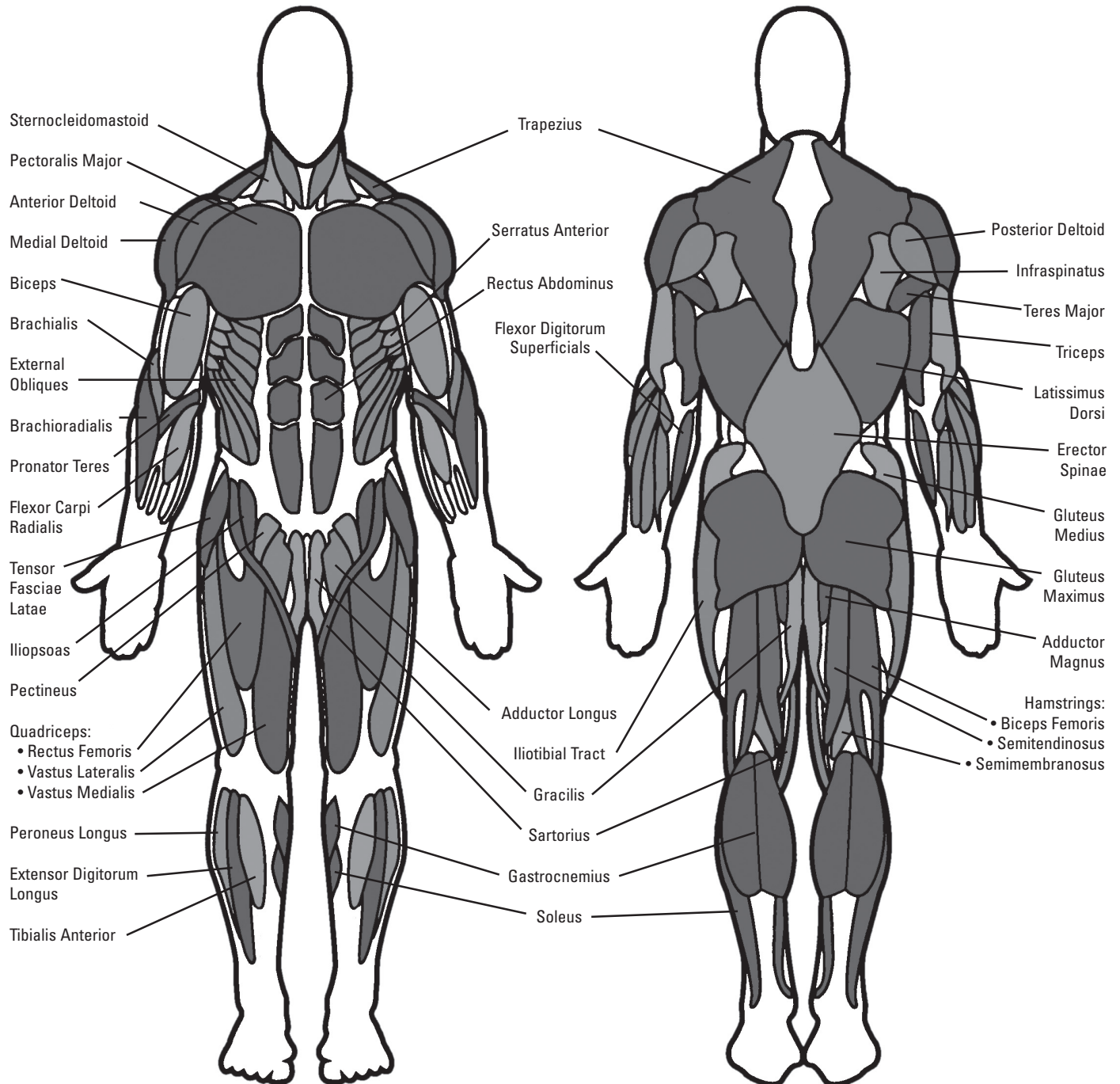

# Exercise Log

Please feel free to make copies of this chart to continue your exercise log.

EXERCISE	DATE	DATE	DATE	DATE	DATE	DATE
<i>Bench Press</i>	Sets	2				
	Reps	10, 9				
	Resistance	120, 130				
	Sets					
	Reps					
	Resistance					
	Sets					
	Reps					
	Resistance					
	Sets					
	Reps					
	Resistance					
	Sets					
	Reps					
	Resistance					
	Sets					
	Reps					
	Resistance					
	Sets					
	Reps					
	Resistance					
	Sets					
	Reps					
	Resistance					
	Sets					
	Reps					
	Resistance					

# Bowflex® Body Weight Loss Guide

## Introduction and Overview

Welcome to the Bowflex® Body Weight Loss Guide. This guide is designed to be used with your Bowflex® equipment and will help you:

- Lose weight and get lean
- Improve your health and wellness
- Increase your energy and vitality

By focusing on the main three elements of the Bowflex® Body Weight Loss Guide- quality, balance, and consistency- you'll be able to reach and maintain your weight loss and fitness goals for the next six weeks and beyond.

- **Quality** – The emphasis of this plan is on eating more whole foods and getting the most nutrients from your calories as possible. Making the majority of your diet from foods that have a single ingredient (for example fruits, vegetables, fish, lean protein, eggs, beans, nuts, and whole grains) provides the vitamins, minerals, fiber, protein, and healthy fats your body needs.
- **Balance** – Each of the meals and snacks in this guide have a source of fiber or smart carbohydrate, protein, and healthy fat to keep your energy levels consistent throughout the day to fuel your workouts. By having this balance you'll feel fuller longer, which is critical to weight loss success.
- **Consistency** – Getting about the same number of calories each day is important for your metabolism and your mindset. If you overdo it one day, don't try to make up for it the next day by not eating or cutting your calories drastically. Get right back on track by following this guide!

## Results & Expectations

Results will vary depending on your age, starting weight, and exercise level but on average you can expect to lose 1-3 lbs per week and experience increased energy levels.

## 5 Tips for Long-Term Success

1. **Keep a food log** including hunger levels and water intake. Free online food logs and mobile apps are available at [www.myfitnesspal.com](http://www.myfitnesspal.com) and [www.loseit.com](http://www.loseit.com)
2. **Weigh and/or take measurements weekly** – no more and no less. Weighing weekly rather than daily or every other day is best. You'll track your progress and keep yourself in check without getting discouraged if the scale doesn't move for a few days. And remember, weight is just a number and it's influenced by muscle gain as well as fat loss. Feeling how your clothes fit can often be a better indicator of progress as your body adapts to exercise and nutrition changes.
3. **Measure portions** – To avoid portion creep, use measuring cups and spoons for grains (rice, pasta, cereal), beans, nuts, oils, and dairy. Use the Portion Sizes Guide for other foods.
4. **Plan ahead** – Make a meal plan for the week or log your food a day in advance. Planning sets you up for success, especially for social events and eating out.
5. **Practice your desired long-term habits** – It's easy to justify poor eating choices when you're only focused on the short term. Focus on the long term satisfaction of a slimmer, healthier you rather than the temporary gratification you'll get from splurging.

## How to Use this Guide

- **Eat breakfast within 90 minutes of waking up and balance your meals and snacks throughout the day**
  - Don't go longer than 5-6 hours without eating
  - If you're not used to eating breakfast, start out small with a piece of fruit and have something else 1-2 hours later. Your body adapts to not eating breakfast, but as soon as you start eating early in the day and cutting back on dinner portions you'll notice your hunger will increase. This is a good sign your metabolism is working!
- **Mix and match meal options**
  - Select 1 option from the appropriate meal plan (male or female) for breakfast, lunch, and dinner, paying close attention to portion sizes
  - Select 1-2 snack options per day
  - You have the option to substitute one snack for one treat under 150 calories
  - Use the meal plan, sample options, and grocery list to create your own meals for more variety
  - You can swap out any type of protein, vegetables or smart carbs for the suggested meal options. For example:
    - Turkey for tuna
    - Any fish or seafood for chicken
    - Cooked vegetables instead of salad

# Bowflex® Body Weight Loss Guide

- **Eat your calories**
  - Cut out high calorie beverages like soda, juices, coffee drinks, and alcohol
  - Stick with water, unsweetened tea, and coffee. Aim for a minimum of 64oz (1.9 liters) of water per day to stay well hydrated
- **If you're still hungry after or in between meals:**
  - Have a glass of water and wait 15-20 minutes. Many times we mistake thirst (or even boredom!) for hunger. Wait out the initial urge to eat and sometimes it will pass.
  - If you're still hungry after waiting 15-20 minutes have a snack or mini-meal with fruit, vegetables, and protein.

## If your goal is muscle gain or strength:

- Use the same meal plan but increase portion sizes in the same ratios to increase the total number of calories you eat every day. For example, increase portion sizes of protein and smart carbs at meals by 50%. Adding a snack is another option to meet your body's increased calorie needs in order to gain muscle and strength.
- Focus on post-workout nutrition by having one of your snacks within 30 minutes after you complete your workout. Make sure to have a combination of carbohydrates such as fruit with protein (yogurt, milk, or protein powder) to promote muscle growth and recovery. Chocolate milk is also a great option.

## Meal Plan Overview

The female meal plan provides about 1400 calories, and the male plan provides about 1600 calories, of high quality nutrition to not only help you lose weight and feel great but get the most out of your calories. The vitamins, minerals, and antioxidants from eating mostly whole foods help support optimal health. These calorie levels will result in healthy weight loss for the majority of people. Keep in mind that everyone's metabolism is very different depending on age, height, weight, activity level, and genetics. Pay close attention to your weight, hunger levels, and energy and adjust your calories if needed.

### Follow these guidelines if you're over 55:

- If you're over 55, you need fewer calories because your metabolism slows as you age. Stick with three meals with one optional snack per day.

### Follow these guidelines if you're under 25:

- If you're under 25 you may need more calories. Add another snack if you feel low on energy or are extremely hungry.

## Breakfast

Breakfast includes a smart carb, fruit, and a source of protein, which will also have fat. With a balance of carbohydrates and fiber from the smart carb and fruit combined with protein and fat, you'll energize your day and help control hunger levels throughout the day.

## Snacks

Each snack is a balance of carbohydrates and protein to keep your blood sugar more consistent, which means you won't experience hunger and energy level spikes and drops.

This happens when you have a high carb-only snack like chips, candy, soda, crackers, or pretzels.

## Lunch and Dinner

Lunch combines filling fiber from vegetables and smart carbs with a lean, or low-fat, protein. The healthy fat can come either from the protein added during cooking (nuts on a salad) or as a dressing or sauce (such as oil and vinegar salad dressing).

# Bowflex® Body Weight Loss Guide

Here's an overview of what an ideal day looks like:  
(See Portion Size Guide for proper serving sizes)

## Breakfast

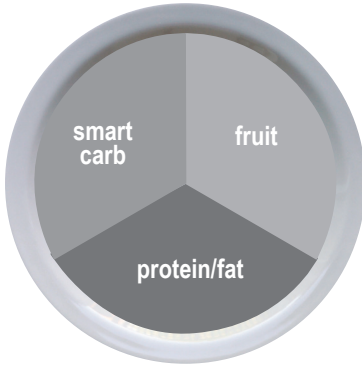

## Snack #1

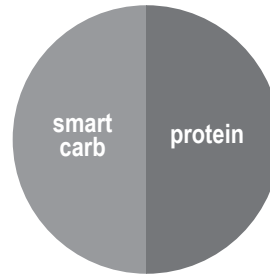

## Lunch

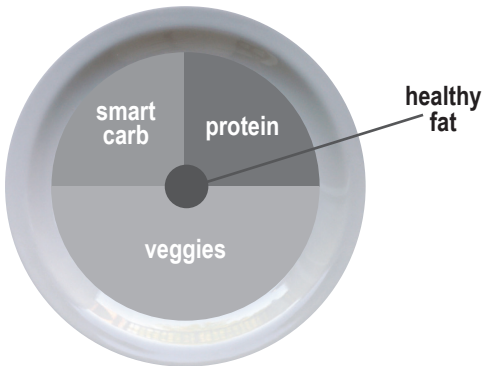

## Snack #2

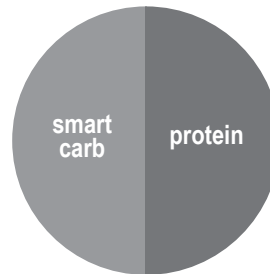

## Dinner

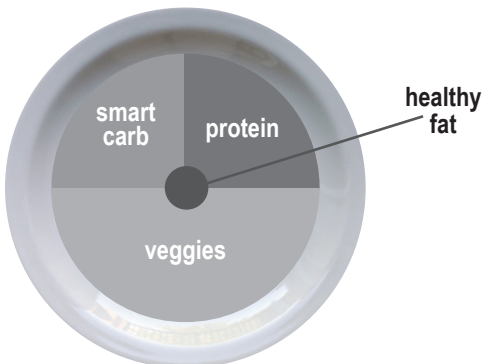



# Bowflex® Body Weight Loss Guide

Breakfast Options	Fruit	Smart Carb	Protein/Fat
<b>Fruit and Nut Oatmeal</b> Cook plain oats in water. Top with fruit, nuts, milk, cinnamon, and honey.	Berries or banana	Plain oats (Regular or quick-cook)	Nuts and milk
<b>Egg Muffin</b> Cook egg/s. Toast bread and top with 1 slice of cheese, 1 slice of ham, and tomato.	Tomato	English muffin or sandwich thin	Egg, ham, and cheese
<b>Yogurt Power Parfait</b> Top yogurt with fruit. Sprinkle with 1 serving of nuts, 2-3 tbsp wheat germ, or ground flaxseed, 1 tbsp oats, and cinnamon.	Chopped fruit of your choice	Oats, wheat germ, and ground flaxseed	Plain non-fat Greek yogurt and nuts
<b>On the Go PB &amp; Apple Sandwich</b> Toast bread. Spread on peanut butter, thin slices of ½ an apple, and 1 teaspoon of honey.	Sliced apple	Sandwich thin, bread, or bagel thin	Peanut butter

Lunch & Dinner Options	Lean Protein	Smart Carb	Veggies
<b>Pork Loin, Sweet Potato &amp; Green Beans</b>	Grilled or baked pork loin	Baked Sweet Potato	Green Beans
<b>Chicken Stir Fry</b> Flavor with 2 tablespoon teriyaki sauce	Chicken breast or boneless skinless thigh	Brown or wild rice	Mixed stir fry vegetables (fresh or frozen)
<b>Steak Tacos with Side Salad</b> (3 for males, 2 for females) Top with salsa, cilantro, and sprinkle of shredded cheese	Flank or sirloin steak	Corn tortillas	Salad
<b>Whole Wheat Pasta with Shrimp or Cannellini Beans &amp; Marinara Sauce</b>	Shrimp (frozen or fresh) or cannellini beans	Whole wheat pasta	Steamed broccoli
<b>Bunless Burgers with Oven Fries, Corn, &amp; Salad</b> Grill burgers. Bake sliced potatoes on sprayed cookie sheet for 25-30 minutes @ 425°F.	93% lean ground beef or turkey	Oven baked fries	Corn on the cob + side salad
<b>Tuna &amp; Avocado Wrap with Vegetable Soup</b> Use 3oz of tuna (1 can). Top with lettuce, tomato, avocado, and mustard.	Tuna	High-fiber wrap	Vegetable soup (homemade or low-sodium canned)

## Bowflex® Body Weight Loss Guide

Snack Options	
Smart Carb	Protein
1 medium apple	10-15 almonds
Baby carrots	2 tbsp hummus
1 serving of crackers*	1 string cheese
Energy or protein bar with <200 calories*	

\*See [www.Bowflex.com/Resources](http://www.Bowflex.com/Resources) for brand recommendations

### Optional Treats

You have the choice of replacing Snack #2 with a 100-150 calorie treat. You can have an optional treat every day but for optimal health it is recommended to limit small splurges to 3-4 times per week. Use the approach that works best for you. Here are a few examples:

- ½ cup lowfat ice cream
- 1 small bag of baked potato chips
- 4oz of wine or 12oz light beer
- 3 cups of air-popped or light popcorn

### Sample 3 Day Plan

Based on each of the meal options listed above, a typical 3 day plan could look like this:

	Day 1	Day 2	Day 3
<b>Breakfast</b>	Egg muffin	Power yogurt parfait	Fruit + nut oatmeal
<b>Snack 1</b>	Apple with almonds	Nut Thins® + string cheese	Baby carrots and hummus
<b>Lunch</b>	Tuna & avocado wrap with soup	Leftovers from dinner- day 1	Leftovers from dinner- day 2
<b>Optional Snack 2 or Treat</b>	½ cup ice cream bar	Energy bar	100 calorie bag of light popcorn
<b>Dinner</b>	Shrimp pasta	Chicken stir fry	Bunless burgers

# Bowflex® Body Weight Loss Guide

## Portion Size Guide

Each of the items listed are for one serving

MALE	FEMALE
<b>PROTEIN</b>	
2 eggs 5oz chicken, fish, lean meat, or tofu 2/3 cup beans or lentils* 1 cup greek yogurt* 1.5oz cheese*	1 egg 3oz chicken, fish, or lean meat 1/2 cup beans or lentils* 1/2 cup greek yogurt* 1.5oz cheese*
<b>HEALTHY FAT</b>	
2 Tblspn peanut or nut butter* 2 tspn olive, flax, or walnut oil 1/4 cup of nuts 1/3 medium avocado	1 tblspn peanut or nut butter* 1 tspn olive, flax or walnut oil 1/8 cup or 2 tablespoons of nuts (approx. 15 almonds) 1/4 medium avocado
<b>SMART CARB</b>	
1 cup cooked grains (1/2 cup raw): oats, brown rice, quinoa, pasta 1 medium sweet or regular potato 2 corn tortillas 1 slice of bread (or 2 light slices equaling 120 calories or less) 1 english muffin, sandwich thin, or high-fiber wrap	1/2 cup cooked (1/4 cup raw) grains 1/2 medium sweet potato or regular potato 2 corn tortillas 1 slice of bread (or 2 light slices equaling 120 calories or less) 1 english muffin, sandwich thin, or high-fiber wrap
<b>FRUIT</b>	
1 medium apple, orange, or pear 1 small banana (length of your hand) 1 cup berries or chopped fruit 1/4 cup dried fruit (fresh or frozen is optimal)	
Vegetables* You can have unlimited vegetables except for peas and corn; stick with 1/2 cup serving	
2 cups spinach or lettuce = 2 cupped hands 1 cup raw vegetables 1/2 cup cooked vegetables 6oz low sodium vegetable juice	
<b>OPTIONAL TREATS</b>	
1/2 cup lowfat ice cream 1 small bag of baked potato chips 1oz dark chocolate 4oz of wine or 12oz light beer 3 cups air-popped or light popcorn	

\* some foods are a combination of protein and carbs or protein and fat



1 cup = baseball



1/2 cup = lightbulb



1 oz or 2 tbsp  
= golf ball

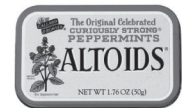

1/4 cup nuts  
= Altoids tin



3 oz chicken or meat  
= deck of cards



1 medium potato  
= computer mouse



1 medium piece of  
fruit = tennis ball



1 - 1/2 oz cheese  
= 3 dice

# Bowflex® Body Weight Loss Guide

## Grocery List

BREAD & GRAINS			
100% whole wheat bread Sprouted grain breads Light or whole wheat english muffins Sandwich or bagel thins Corn or low-carb whole wheat tortillas High-fiber wraps Plain oats: 1 minute or old fashioned Whole grains: brown rice, bulgar, barley, quinoa, couscous	Tips: Look for 100% whole wheat as the first ingredient. Look for 4g of fiber per slice or 5g per 2 slices of light or diet bread. Aim for bread with less than 100 calories per slice.		
DAIRY & DAIRY ALTERNATIVES	CRACKERS, SNACKS & ENERGY BARS		
Plain non-fat greek yogurt Kefir (yogurt like drink) Organic low-fat milk Enriched almond or soy milk Cheese: feta, parmesan, mozzarella, light havarti, provolone, swiss, string cheese, or single serving packages	<table border="1"> <tr> <td>           Any unsalted nuts or seeds            Air-popped or light popcorn            Edamame in the pod         </td> <td>           Energy bars            Crackers            Hummus         </td> </tr> </table>	Any unsalted nuts or seeds Air-popped or light popcorn Edamame in the pod	Energy bars Crackers Hummus
Any unsalted nuts or seeds Air-popped or light popcorn Edamame in the pod	Energy bars Crackers Hummus		
	Tips: Limit crackers, pretzels, and chips to 2-3 servings per week. Always pair with protein such as hummus, cheese, or nuts. Look for energy bars with less than 200 calories and 20g of sugar and at least 3g of protein and 3g of fiber. Look for crackers with less than 130 calories and 4g or less of fat per serving.		
MEAT, FISH, POULTRY & PROTEIN	FATS & OILS		
Wild game Salmon, halibut, tuna, tilapia, shrimp, catfish, scallops, or crab Pork loin, pork chops, or pork roast Chicken or turkey breast or thighs (no skin) Eggs and 100% egg whites Lean beef: sirloin, chuck, round, tenderloin, 93% lean (organic and grass fed is best) Canned salmon or tuna (in water) Nitrate-free, reduced sodium ham, turkey, chicken, or roast beef lunch-meat Any type of bean, dry or canned low-sodium varieties Tofu and tempeh	Avocado Olive, grapeseed, walnut, sesame, or flaxseed oil Butter/spreads: look for products free of trans fats and partially hydrogenated oils on the ingredient list.		
	Tips: Light olive oil refers to the flavor, not the calorie content. Always measure oil and butter. Even if a fat is considered healthy, it's still very high in calories and portions need to be controlled.		
	DRESSINGS, CONDIMENTS & SAUCES		
Tips: Look for "Choice" or "Select" cuts of meat rather than "Prime". Prime cuts are fattier. Limit intake of highly processed meat and imitation meat products like sausage, bacon, pepperoni, and hot dogs to once a week or less.	Vinegars: rice, wine, balsamic All fresh or dried herbs and spices Mustard Salsa and chili sauce Marinara sauce with no high-fructose corn syrup Lemon and lime juice Bottled minced garlic and ginger Low-sodium soy sauce		
FROZEN FOODS	Tips: Look for products free of MSG, added colors, and high fructose corn syrup. Look for sauces under 50 calories per serving. Avoid cream based sauces and dressings like ranch, bleu cheese, and alfredo.		
All vegetables without sauce All fruit Grains and grain medleys			

All fruits and vegetables, fresh and frozen, are great choices. Since every meal has one or both, your shopping cart should reflect this.

# Bowflex® Body Weight Loss Guide

---

## Keep It Going

### Tips for continued weight loss and maintaining changes

- **Keep weighing yourself weekly**, even after you've reached your goal weight
- **Continue keeping a food log.** If you have your meal plan well-established, log your food every other week to keep yourself on track. Don't feel like you have to do it every day.
- **Prepare for plateaus.** The scale might not budge for a few weeks or even months after some initial weight loss. This is normal and to be expected. It's the body's natural process for adjusting to your new lower weight. Stay focused on your long-term goal, celebrate your successes and changes, and mix up your workouts to help overcome the plateau.
- **Calorie adjustments for maintaining weight loss.** Once you've reached your goal weight, you can increase your calories 100-200 per day as long as your activity level stays the same
- **Treat yourself.** Have a non-food reward for each goal you hit such as a massage, a new outfit, or an outing with friends and family
- **Use the resources below** to find new recipes, get expert advice, and support to stay motivated

## Resources

### Downloadable Resources from Bowflex® Website ([www.Bowflex.com/Resources](http://www.Bowflex.com/Resources))

- Grocery Shopping List for Fridge (Blank Form)
- 7 Day Meal Planning Form
- Additional Dinner Options
- Pre and Post Workout Fueling Guide

### Questions & Support

- Ask questions, post suggestions, and connect with our online Bowflex® Dietitian on the Bowflex® Facebook page

### Recipes

- [www.wholeliving.com](http://www.wholeliving.com)
- [www.eatingwell.com](http://www.eatingwell.com)
- [www.whfoods.org](http://www.whfoods.org)
- [www.livebetteramerica.org](http://www.livebetteramerica.org)

### Online food logs

- [www.myfitnesspal.com](http://www.myfitnesspal.com)
- [www.loseit.com](http://www.loseit.com)



## Bowflex Revolution® 100% Satisfaction Guarantee

---

We want you to know that your Bowflex Revolution® machine is a superior product. Your satisfaction is guaranteed. If, for any reason, you are not 100% satisfied with your Bowflex Revolution® machine, please follow the instructions below to return your merchandise and receive a refund of the purchase price, less shipping and handling.

This Bowflex Revolution® Satisfaction Guarantee applies only to merchandise purchased by consumers directly from Nautilus, Inc. This guarantee does not apply to sales made by dealers or distributors.

1. Call a Bowflex® Representative at 1-800-NAUTILUS (1-800-628-8458) for a Return Authorization Number (RMA). An RMA will be granted if:
  - a. The Bowflex Revolution® exercise machine was purchased directly from Nautilus, Inc.
  - b. The request to return the product is within 6 weeks of the delivery date of your merchandise.
2. If an RMA is granted, the following instructions will prevent delays in the processing of your refund.
  - a. The merchandise must be returned to the address given to you at the time of the Return Authorization Call.
  - b. All returned merchandise must be properly packaged in good condition, preferably in the original boxes.
  - c. The exterior of the boxes should be marked clearly with:
    - Return Authorization Number
    - Your Name
    - Your Address
    - Your Phone Number
  - d. Additionally, a piece of paper with your name, address and phone number or copies of your original invoice should be placed in each box of merchandise.
  - e. Your RMA number is time sensitive. Your shipment must be post marked within two weeks from the date the TreadClimber® Representative issued the Return Authorization Number.

**NOTE:** You are responsible for return shipping and for any damage or loss to merchandise that occur during return shipment. Nautilus recommends that you obtain tracking numbers and insure your shipment.

### Unauthorized Returns

Nautilus, Inc. defines an unauthorized return as any merchandise returned to our facilities without a valid and current Return Merchandise Authorization (RMA) number issued by Nautilus. Failure to properly mark packages with a valid RMA number, or allowing an RMA number to expire, will cause Nautilus, Inc. to consider a return unauthorized. Any merchandise returned without a RMA number will not be subject to a refund or credit and Nautilus will discard the product. The customer assumes all shipping and handling charges for any unauthorized return.

