

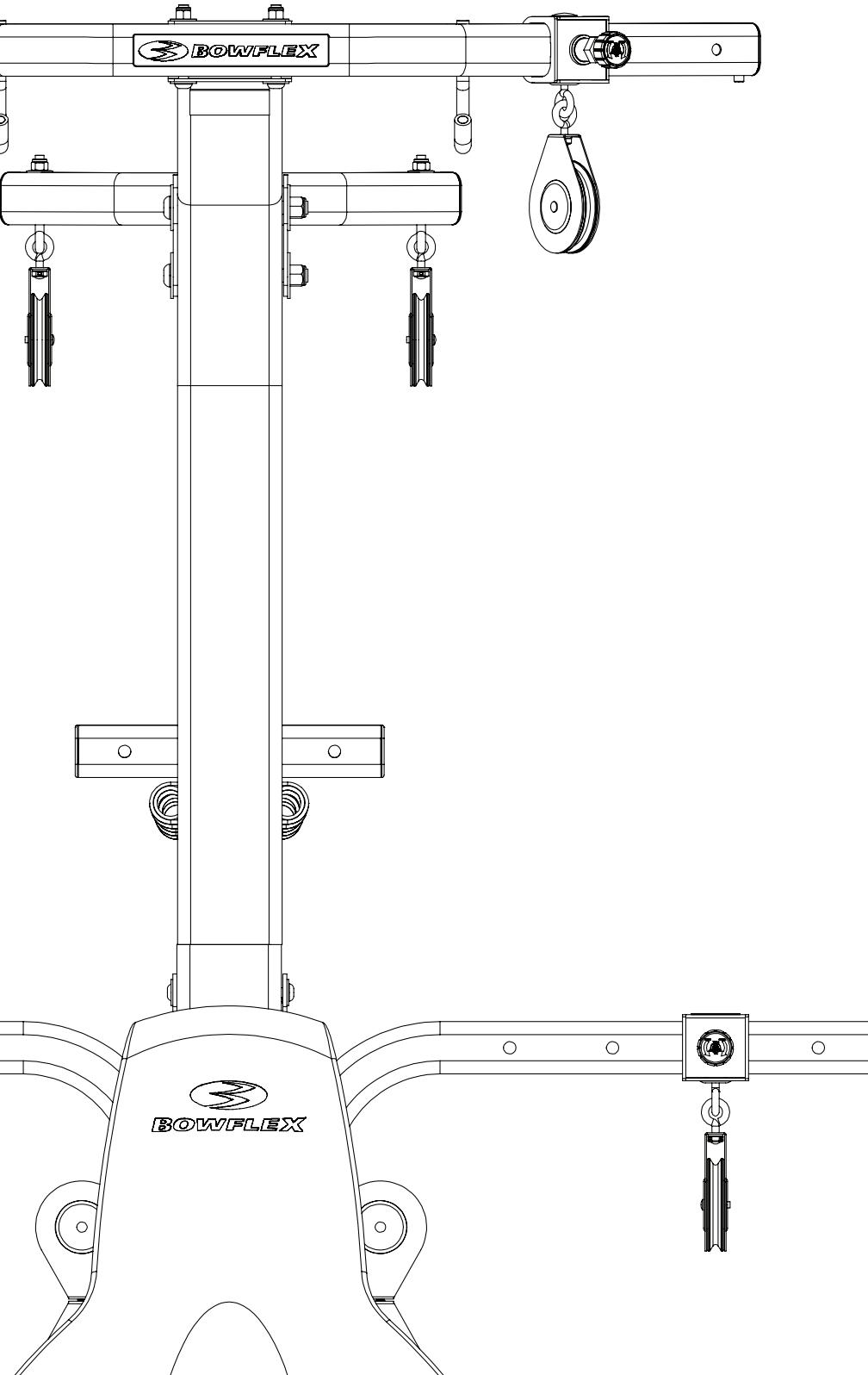

# **BOWFLEX**

## **XTREME 2 SE**



### ASSEMBLY MANUAL

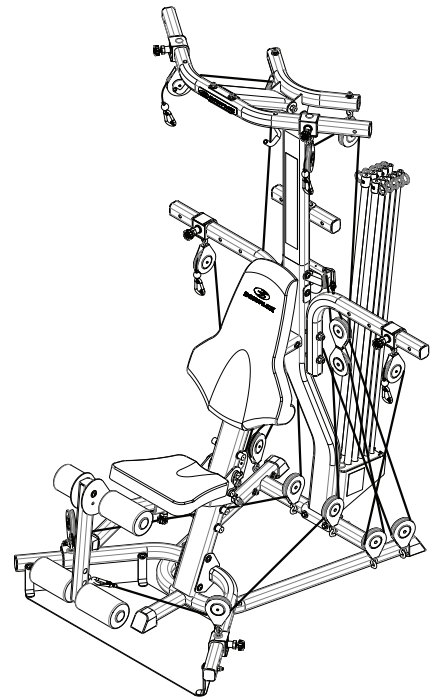

For assembly video, please visit:  
[www.bowflex.com/getting-started.html](http://www.bowflex.com/getting-started.html)



# Table of Contents / Registration

**Congratulations** on your commitment to fitness and your purchase of the Bowflex Xtreme™ 2 SE home gym. Before assembling your Bowflex Xtreme™ 2 SE home gym please read the Assembly Manual and follow the Important Safety Precautions. For information on how to use your Bowflex Xtreme™ 2 SE home gym, refer to the Bowflex Xtreme™ 2 SE Owner's Manual.

Important Safety Instructions - Assembly	3
Before Assembly	3
Parts	4
Hardware	6
Assembly	7
Cable and Pulley Routing	16

To validate warranty support, keep the original proof of purchase and record the following information:

Serial Number \_\_\_\_\_ Date of Purchase \_\_\_\_\_

**If purchased in US/Canada:** To register your product warranty, go to: [www.bowflex.com/register](http://www.bowflex.com/register)

Or call 1 (800) 605-3369.

If you have questions or problems with your product, please call 1 (800) 605-3369.

**If purchased outside US/Canada:** To register your product warranty, contact your local distributor.

For details regarding product warranty or if you have questions or problems with your product, please contact your local distributor.

To find your local distributor, go to: [global.bowflex.com](http://global.bowflex.com)

Nautilus, Inc., 5415 Centerpoint Parkway, Groveport, OH 43125 USA, [www.NautilusInc.com](http://www.NautilusInc.com) - Customer Service: North America (800) 605-3369, [csnls@nautilus.com](mailto:csnls@nautilus.com)  
| Nautilus (Shanghai) Fitness Equipments Co, Ltd, Room 1701 &1702, 1018 Changning Road, Changning District, Shanghai, China 200042, [www.nautilus.cn](http://www.nautilus.cn) - 86  
21 6115 9668 | outside U.S. [www.nautilusinternational.com](http://www.nautilusinternational.com) | Printed in China | © 2008 Nautilus, Inc. | Bowflex, the B logo, Bowflex Xtreme, Power Rod, Nautilus,  
JRN Y and Schwinn are trademarks owned by or licensed to Nautilus, Inc., which are registered or otherwise protected by common law in the United States and other  
countries.

 Indicates a potentially hazardous situation which, if not avoided, could result in death or serious injury.

**Before using this equipment, obey the following warnings:**

 **Read and understand all warnings on this machine.  
Carefully read and understand the Assembly Manual.**

- Keep bystanders and children away from the product you are assembling at all times.
- Do not assemble this machine outdoors or in a wet or moist location.
- Make sure assembly is done in an appropriate work space away from foot traffic and exposure to bystanders.
- Some components of the machine can be heavy or awkward. Use a second person when doing the assembly steps involving these parts. Do not do steps that involve heavy lifting or awkward movements on your own.
- Set up this machine on a solid, level, horizontal surface.
- Do not try to change the design or functionality of this machine. This could compromise the safety of this machine and will void the warranty.
- If replacement parts are necessary use only genuine replacement parts and hardware supplied by Nautilus. Failure to use genuine replacement parts can cause a risk to users, keep the machine from operating correctly and void the warranty.
- Do not use until the machine has been fully assembled and inspected for correct performance in accordance with the Owner's Manual.
- Read and understand the complete Owner's Manual supplied with this machine before first use. Keep the Owner's and Assembly Manuals for future reference.
- Do all assembly steps in the sequence given. Incorrect assembly can lead to injury or incorrect function.
- **SAVE THESE INSTRUCTIONS.**

## Before Assembly

Select the area where you are going to set up and operate your machine. For safe operation, the location must be on a hard, level surface.

Select a workout area that provides a minimum clearance behind the rod box of 0.5 ft (15 cm) and a total width of 6.5 ft (2.0 m). Allow a minimum of 3.0 ft (0.9 m) free space in front of the machine. Be sure that the workout space you are utilizing has adequate height clearance—8 ft. (2.44 m) ceiling.

## Basic Assembly Tips

Follow these basic points when you assemble your machine:

- To make the assembly process go faster, gather the pieces you need for each step and thoroughly read the assembly instructions for that step before starting assembly for the step.
- When tightening a locknut on a bolt, use a combination wrench to grip the locknut and make sure that it is fastened securely.
- When attaching two pieces, gently lift and look through the bolt holes to help guide the bolt through the holes.
- As a general rule, and for all bolts and nuts on your Bowflex Xtreme™ 2 SE home gym, turn bolts or nuts toward the right (clockwise) to tighten and left (counterclockwise) to loosen.

**IMPORTANT: LEAVE ALL CABLES COILED AND WRAPPED UNTIL YOUR BOWFLEX XTREME™ 2 SE HOME GYM IS FULLY ASSEMBLED.**

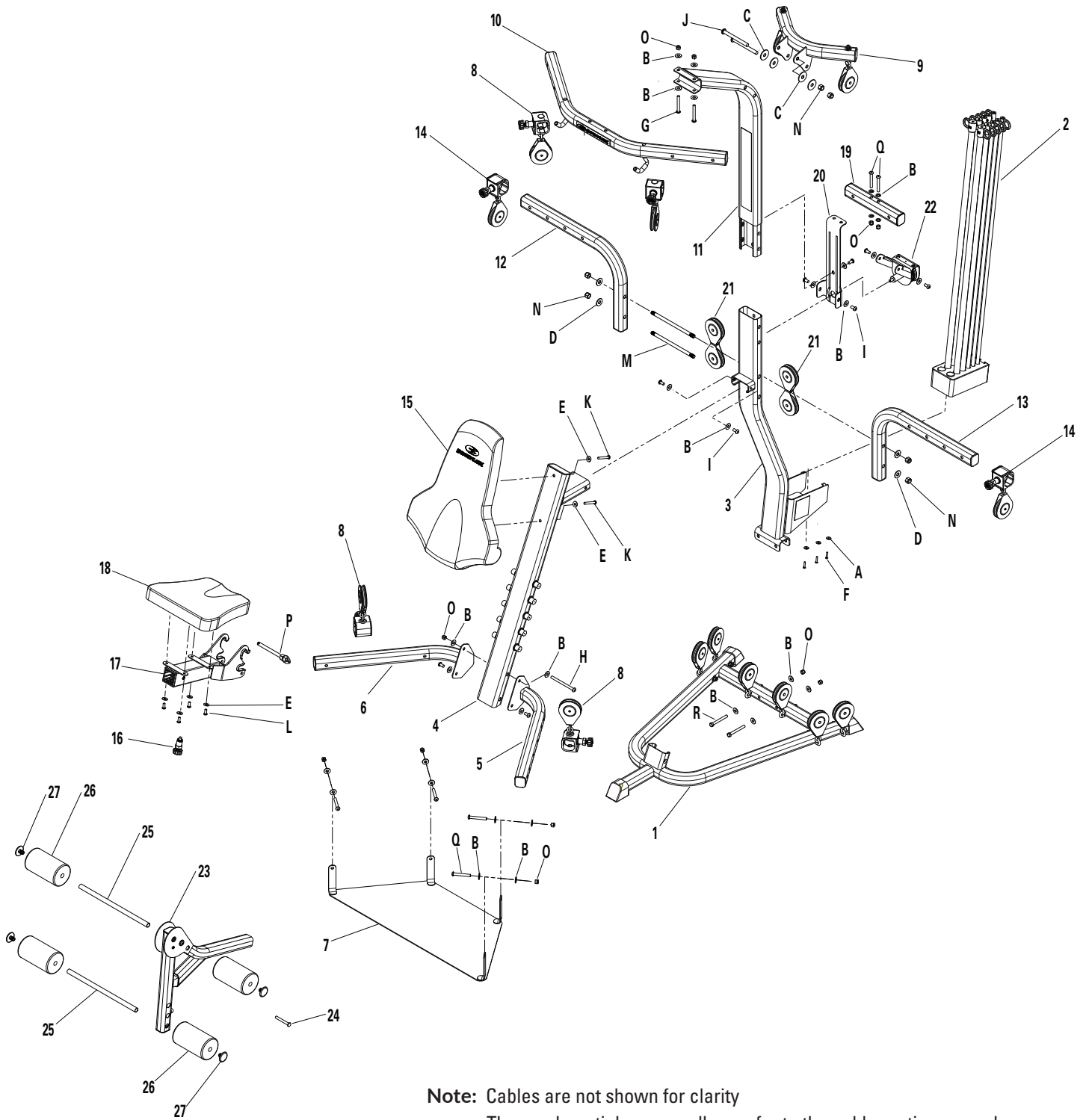

**Note:** Cables are not shown for clarity  
The number stickers on pulleys refer to the cable routing procedure.

Item	Qty	Description	Item	Qty	Description
1	1	Base Frame Assembly	16	1	Lock Knob
2	1	Rod Pack 210#	17	1	Seat Backbone Assembly
3	1	Lower Lat Tower	18	1	Seat Bottom
4	1	Seat Support Rail	19	1	Ab Crunch Crossbar
5	1	Squat Frame Left	20	1	Ab Crunch Bracket
6	1	Squat Frame Right	21	2	Pulley, Pair Floating
7	1	Squat Platform	22	1	Lat Double Pulley / Housing
8	4	Pulley Slider, 4" w/o Decal	23	1	Leg Extension Backbone
9	1	Rear Lat Crossmember	24	1	Leg Extension Pin
10	1	Lat Cross Bar Assembly	25	2	Tube, Foam Roller
11	1	Upper Lat Tower Tube	26	4	Pad, Foam Roller
12	1	Pulley Arm Assembly, Right	27	4	End Cap 3/4"
13	1	Pulley Arm Assembly, Left	28	1	Rod Cables Assembly, Pair
14	2	Pulley Slider, 4" w/ Decal	29	1	Squat Cables Assembly, Pair
15	1	Seat Back Pad			

## Bowflex Xtreme™ 2 SE Box Contents

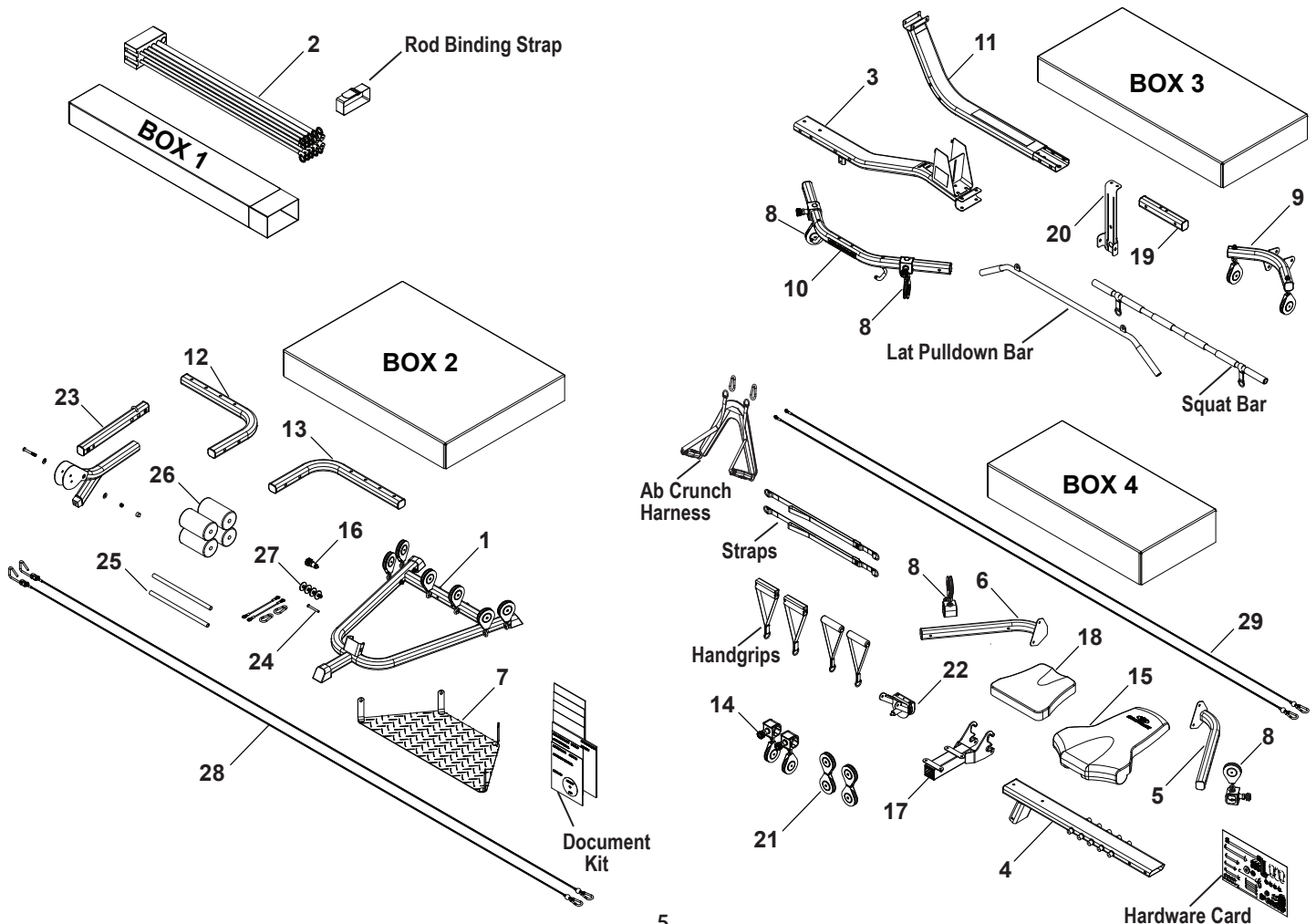

# Hardware

(NOTE: Drawings not to scale.)

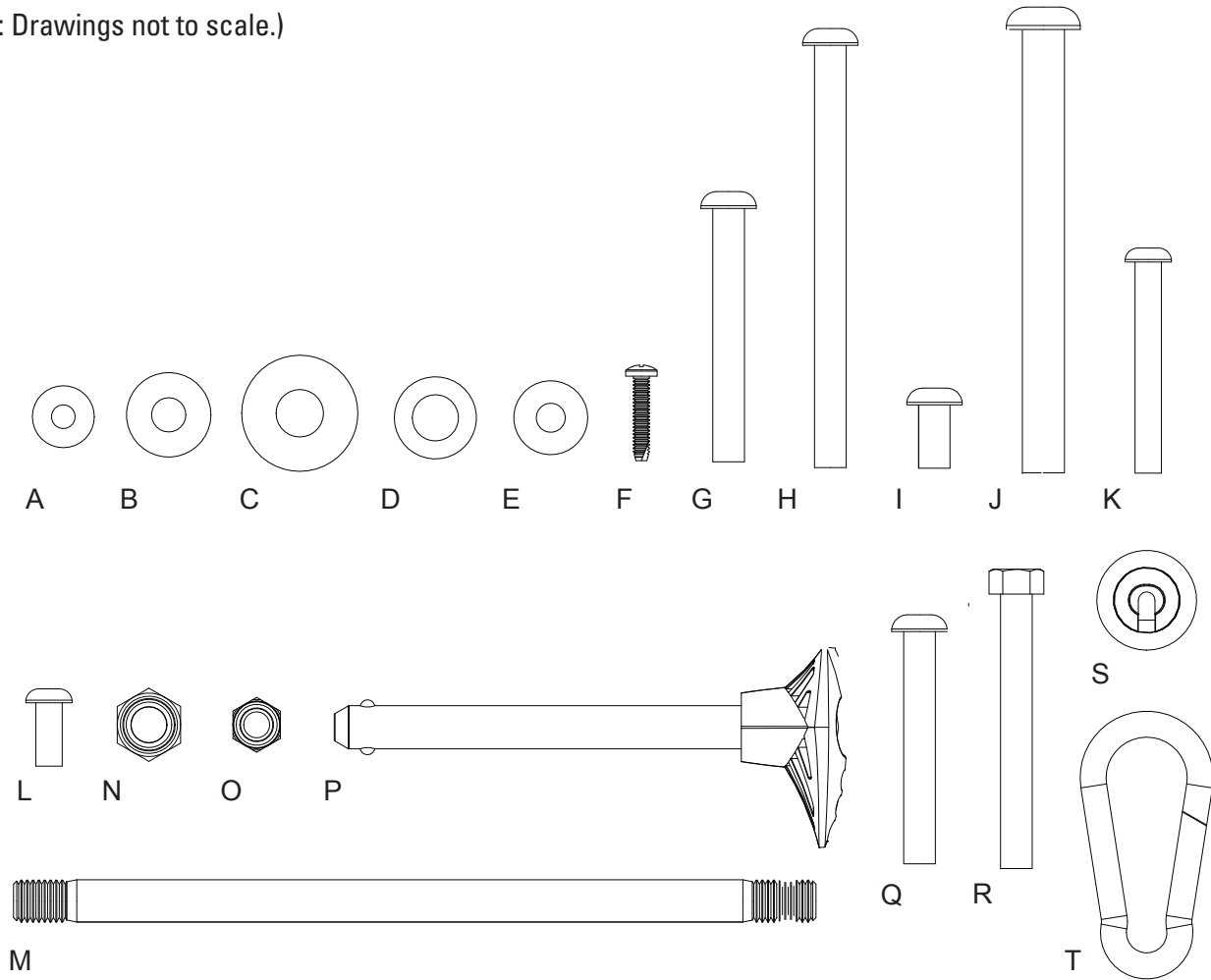

Item	Qty	Description	Item	Qty	Description
A	3	Flat Washer 1/4" Regular	K	2	Button Head Screw 5/16" X 2 1/2"
B	31	Flat Washer 3/8" Regular	L	4	Button Head Screw 5/16" X 3/4"
C	4	Flat Washer 1/2" Wide	M	2	Threaded Stud 1/2" X 9 1/2"
D	4	Flat Washer 1/2" Regular	N	6	Nylock Nut 1/2"
E	6	Flat Washer 5/16" Regular	O	11	Nylock Nut 3/8"
F	3	Phillips Screw #10-16 X 1"	P	1	Seat Locking Pin
G	2	Button Head Screw 3/8" X 3"	Q	6	Button Head Screw 3/8" X 2 3/4"
H	1	Button Head Screw 3/8" X 5"	R	2	Hex Head Bolt 3/8" X 3 1/4"
I	9	Button Head Screw 3/8" X 3/4"	S	4	Cable End Stop Ball
J	2	Button Head Screw 1/2" X 5 1/4"	T	6	Snaphook

## Tools

### Included



3/16"  
7/32"  
5/16"

### Not Included (recommended)

- 7/16" Combination Wrench
- 9/16" Combination Wrench
- Adjustable Wrench
- Socket Wrench Set
- Phillips Screw Driver
- Flat Blade Screw Driver
- Rubber Mallet
- Utility Knife
- Scissors

## Assembly

### 1. Install Power Rod™ Pack to Lower Lat Tower Assembly

#### Parts:

- Lower Lat Tower (3)
- Rod Box with Power Rod™ Pack (2)

#### Hardware:

- 3 Phillips Screws #10 X 1" (F)
- 3 Flat Washers 1/4" (A)

**Tool:** Phillips Screw Driver

**1-1** Lay parts on floor as shown. Firmly slide Rod Box into Lower Lat Tower frame.

**1-2** Fasten the Rod Box to the Lower Lat Tower frame as shown. Tighten screws until snug.

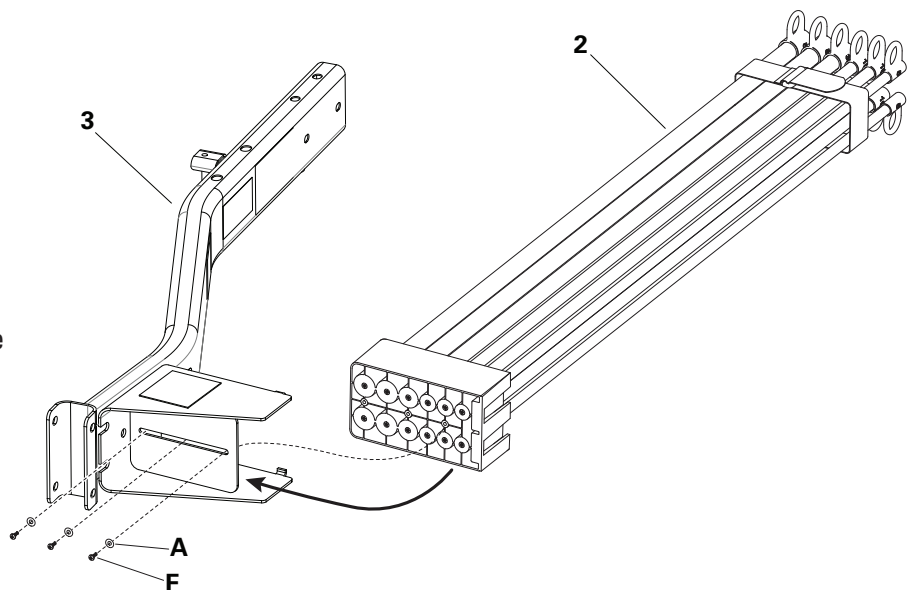

## 2. Install Lower Lat Tower Assembly

### Parts:

- Lower Lat Tower Assembly
- Base Frame Assembly (1)

### Hardware:

- 2 Hex Head Bolts 3/8" X 3 1/4" (R)
- 4 Flat Washers 3/8" (B)
- 2 Nylock Nuts 3/8" (O)

**Tool:** 7/32" Hex Wrench

**2-1** Align the Lower Lat Tower Assembly over the Base Frame.

**2-2** Secure Lower Lat Tower Assembly using screws and washers as shown.

**Finger tighten screws at this time.**

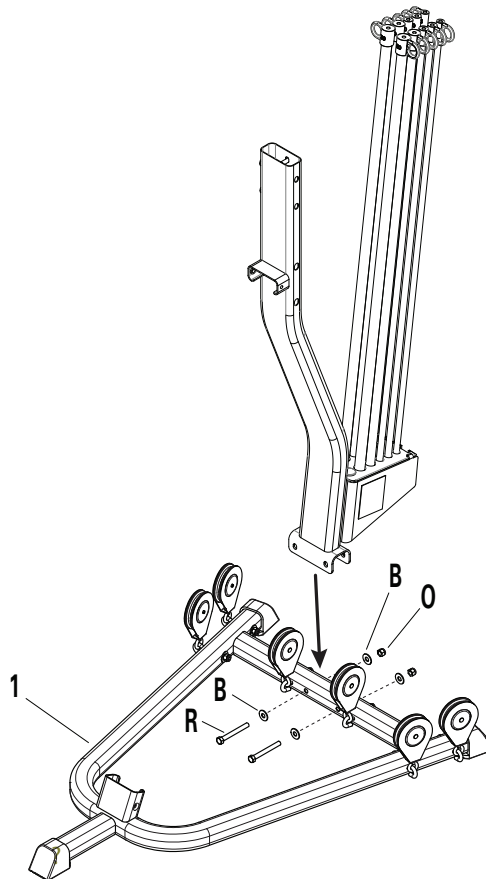

## 3. Install Seat Support Rail

### Parts:

- Seat Support Rail (4)
- Base Frame Assembly

### Hardware:

- 2 Button Head Screws 3/8" X 3/4" (I)
- 2 Flat Washers 3/8" (B)

**Tool:** 7/32" Hex Wrench

**3-1** Slide the bottom of the Seat Support Rail onto the Base Frame connector as shown.

**3-2** Slide the top of the Seat Support Rail onto the Lower Lat Tower Assembly connector as shown. Secure using screws and washers as shown.

**Finger tighten screws at this time.**

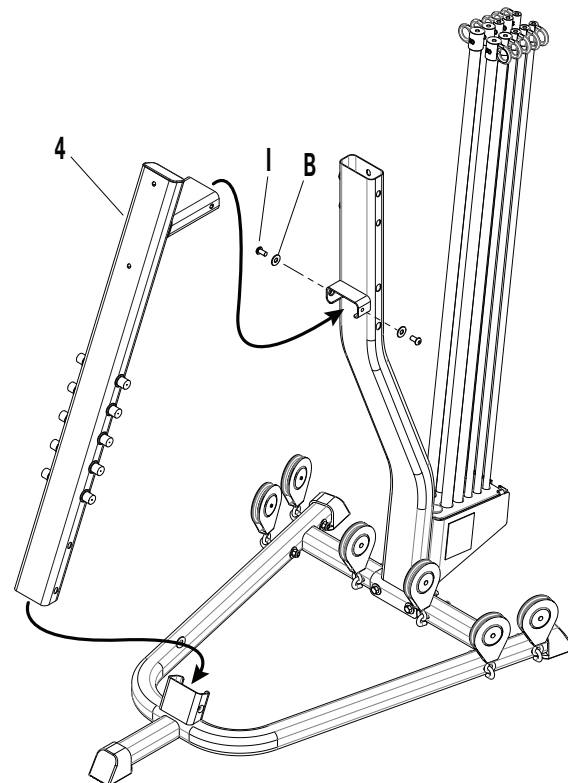



## 4. Install Squat Pulley Frame

### Parts:

- Left Squat Pulley Frame (5)
- Right Squat Pulley Frame (6)
- Main Assembly
- 2 Slider Pulleys w/o Decal (8)
- Squat Platform (7)

### Hardware:

- 1 Button Head Screw 3/8" X 5" (H)
- 5 Nylock Nut 3/8" (O)
- 2 Button Head Screws 3/8" X 3/4" (I)
- 12 Washers 3/8" (B)
- 4 Button Head Screws 3/8" X 2 3/4" (Q)

**Tools:** 7/32" Hex Wrench, Adjustable or Socket Wrench

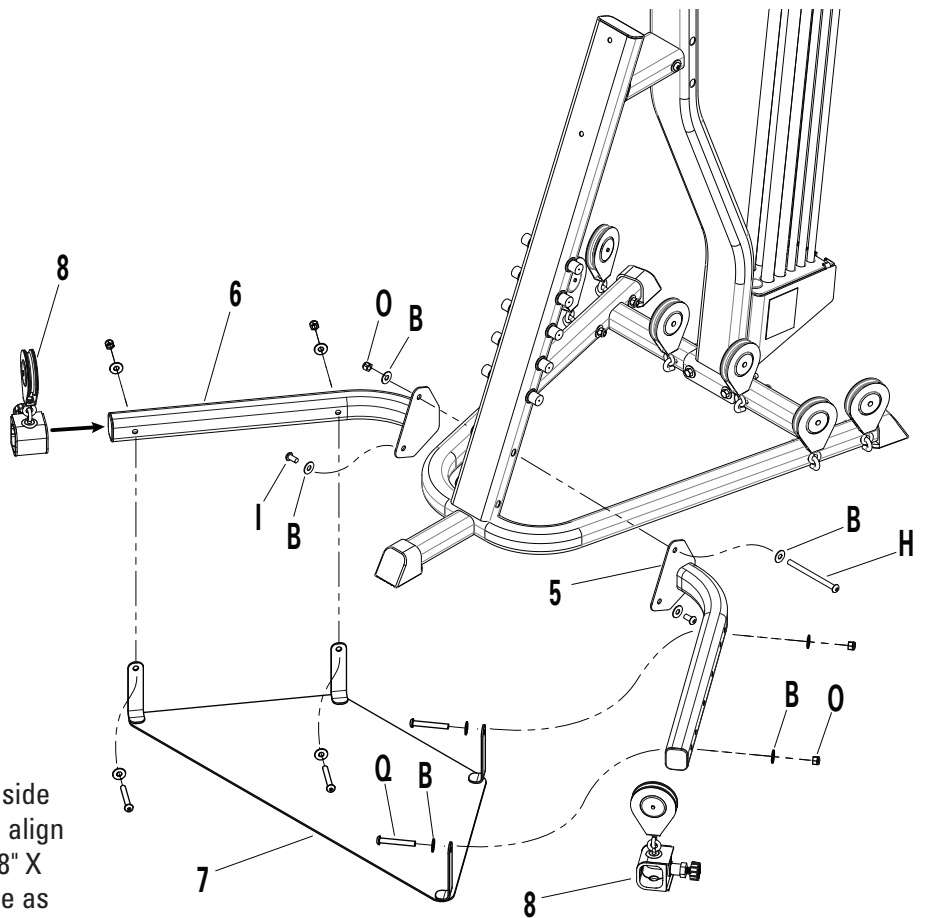

**4-1** Place one Squat Pulley Frame on each side of the Seat Support Rail as shown, and align the top screw holes. Secure using a 3/8" X 5" screw, washer and nut in the top hole as shown.

**4-2** Install screws and washers through the bottom holes of each Squat Pulley Frame into the Support Rail as shown.

**4-3** Put the Squat Platform in position under the front foot of the Base Frame Assembly. Align the screw holes in the Squat Platform brackets with the screw holes on the inner side of each Squat Pulley Frame.

**4-4** Slide one Slider Pulley onto the free end of the Left Squat Pulley Frame as shown.

**Note:** Be sure the Slider Pulley knob points away from the Squat Platform.

Lock the pulley in position near the Seat Support Rail.

**4-5** Install the hardware to attach the Squat Platform to the Left Squat Pulley Frame.

**4-6** Repeat Steps 4-3 through 4-5 for the Right Squat Pulley Frame.

## 5. Install Pulley Arms

### Parts:

- Right Pulley Arm (12)
- Left Pulley Arm (13)
- Main Assembly

### Hardware:

- 2 Threaded Studs 1/2" X 9 1/2" (M)
- 4 Nylock Nuts 1/2" (N)
- 4 Washers 1/2" (D)

**Tools:** 3/4" Socket and Wrench, Adjustable Wrench, Rubber Mallet

- 5-1** Align the two holes in the Pulley Arms with those in the Lower Lat Tower Assembly and secure using threaded studs, 1/2" washers and nuts as shown.

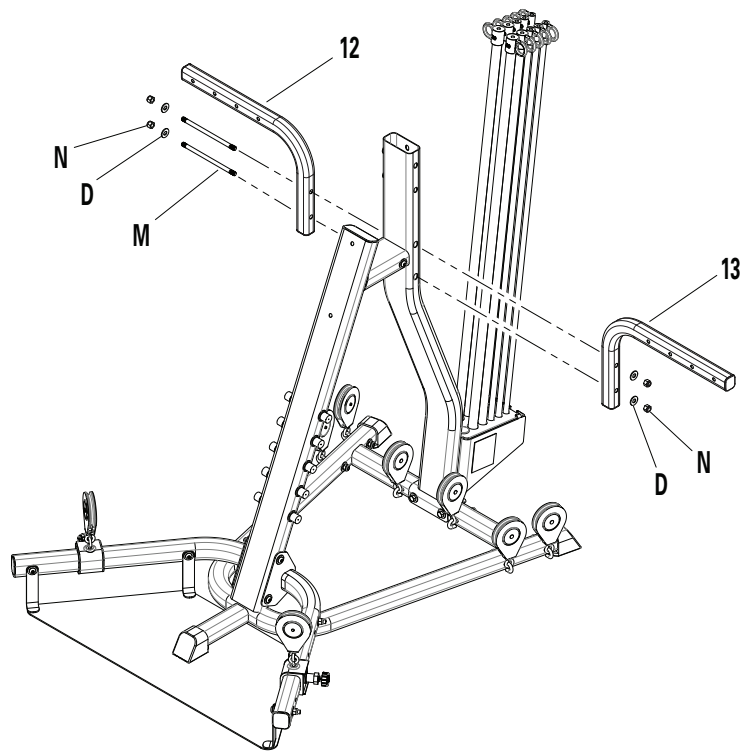

## 6. Install Slider Pulleys

### Parts:

- 2 Slider Pulleys w/ Decal (14)
- Main Assembly

**Tools:** 3/16" Hex Wrench

- 6-1** Install a Slider Pulley onto each Pulley Arm as shown.

- 6-2** Choose any of the four holes to secure.

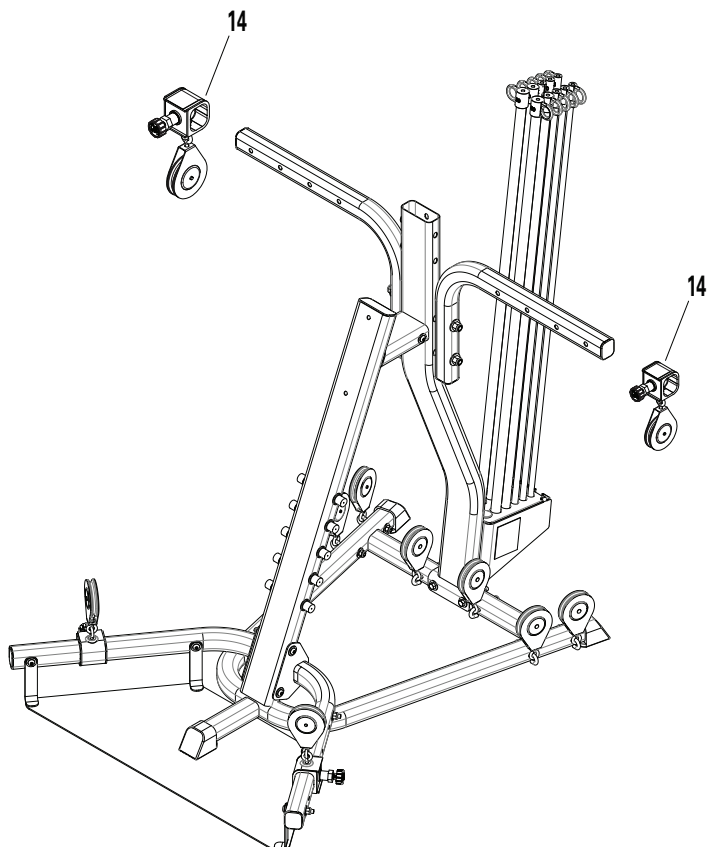

## 7. Seat Assembly

### Parts:

- Seat Backbone (17)
- Seat Bottom (18)

### Hardware:

- 4 Button Head Screws 5/16" X 3/4" (L)
- 4 Washers 5/16" (E)

**Tool:** 3/16" Hex Wrench

- 7-1** Install the Seat Backbone to the underside of the Seat Pad using screws and washers as shown.

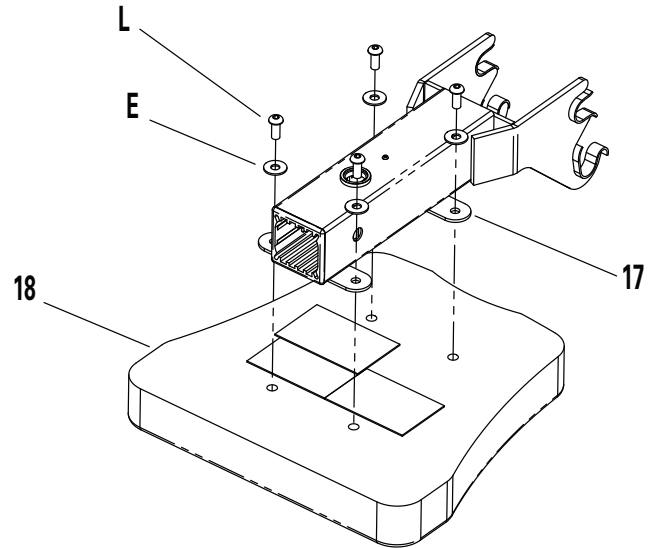

## 8. Leg Extension Assembly

### Parts:

- Leg Extension Backbone (23)
- 2 Chrome Tubes (25)
- 4 Foam Rollers (26)
- 4 End Caps (27)
- Leg Extension Pin (24)

**Tool:** Rubber Mallet

- 8-1** Insert Chrome Tubes through the upper hole and one of the lower holes in the Leg Extension. (Select hole for your comfort level.)

- 8-2** Slide Foam Rollers onto the Chrome Tubes and secure with end caps. A rubber mallet may be needed to secure the end caps.

**Note:** The Leg Extension may be adjusted during workout to best suit your height and personal preferences.

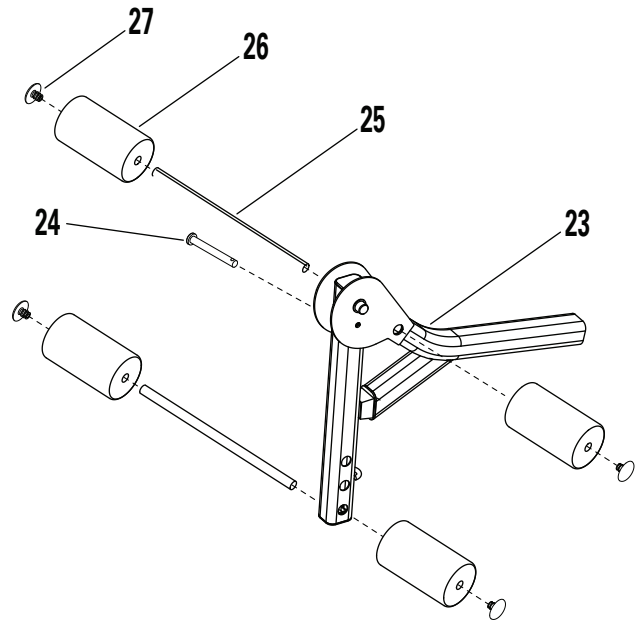

## 9. Install Leg Extension Assembly

### Parts:

- Leg Extension Assembly
- Lock Knob (16)
- Seat Assembly

**9-1** Insert Leg Extension Backbone into open end of Seat Backbone as shown.

**9-2** Align one hole of the Leg Extension with the hole in the Seat Backbone to fit your height and secure with the Lock Knob as shown.

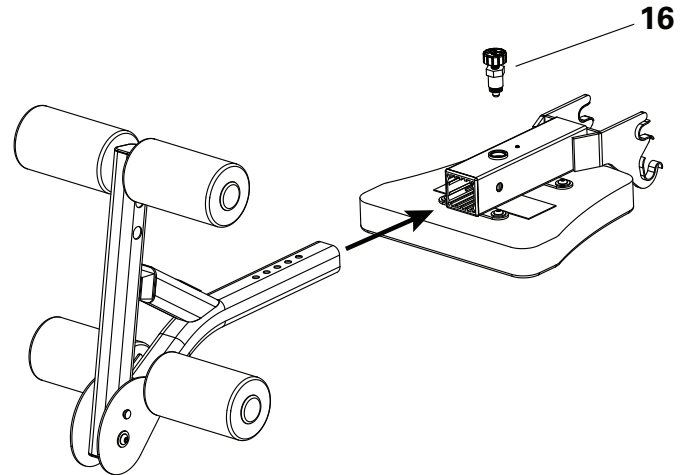

## 10. Install Seat Back Pad

### Parts:

- Seat Back Pad (15)
- Main Assembly

### Hardware:

- 2 Button Head Screws 5/16" X 2 1/2" (K)
- 2 Washers 5/16" (E)

**Tool:** 3/16" Hex Wrench

**10-1** Align the screw holes on the Seat Back Pad with the screw holes on the Seat Support Rail.

**10-2** Install the Seat Back Pad to the Seat Support Rail using screws and washers as shown.

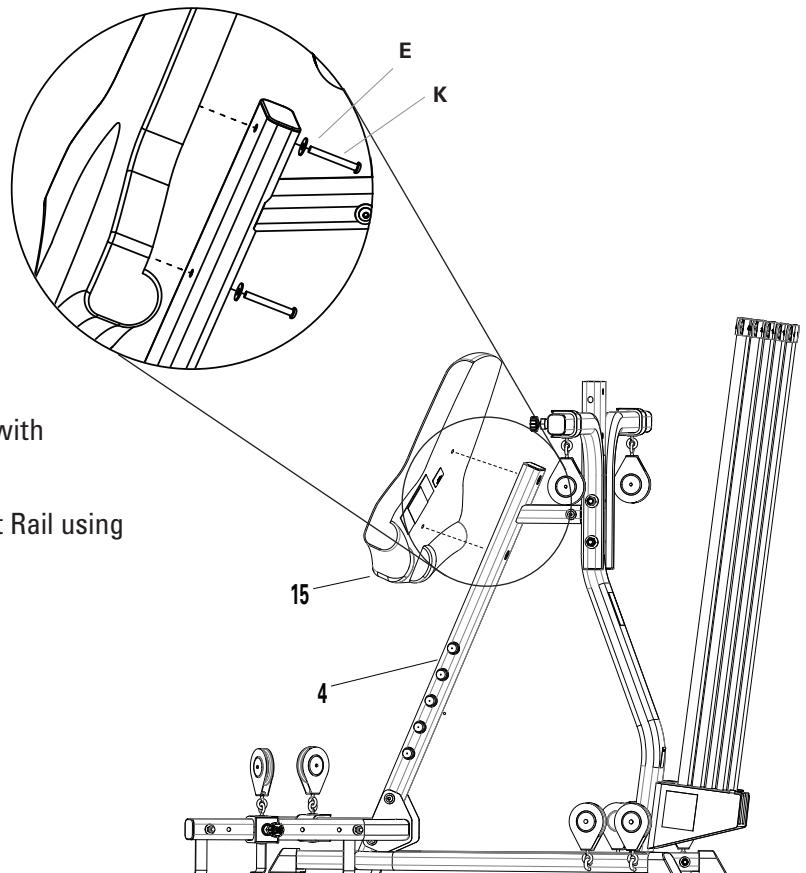

## 11. Install Seat Assembly

### Parts:

- Seat Assembly
- Seat Locking Pin (P)
- Main Assembly

**11-1** Align the top two hooks on the Seat Backbone (17) with one of the pairs of pins on the Seat Support Rail (4), as shown in **Detail 11a**.

**11-2** Tip seat front up and slide hooks onto pins. Rotate seat down and back to use.

**11-3** Slide the Seat Locking Pin through the holes in the Seat Backbone hooks to secure the seat assembly on the Seat Support Rail as shown in **Figure 11b**.

**Note:** Reverse procedure to remove seat.

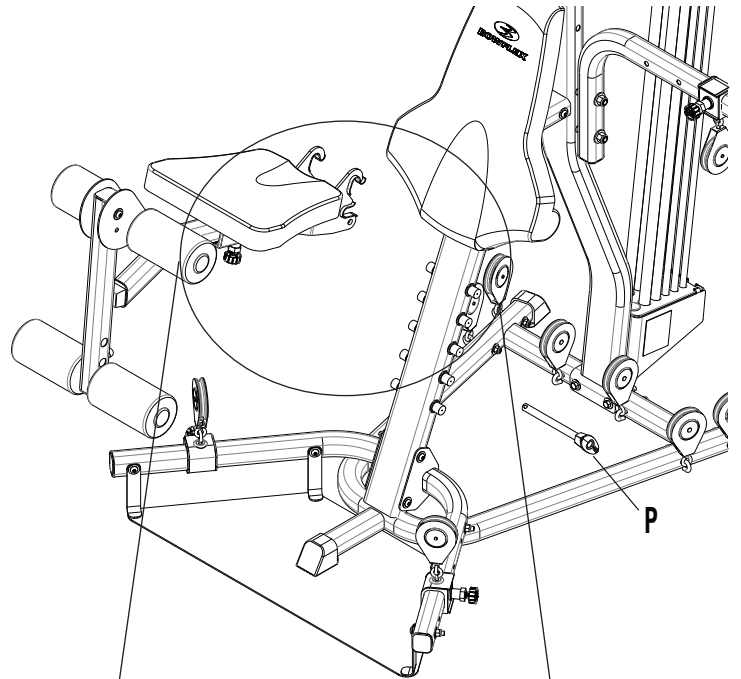

**Detail 11a**

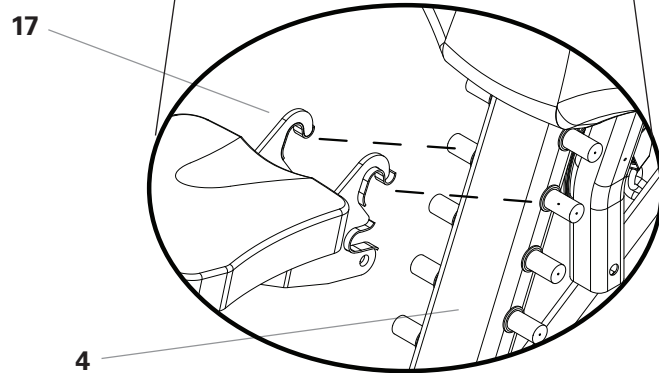

**Detail 11b - Back View**

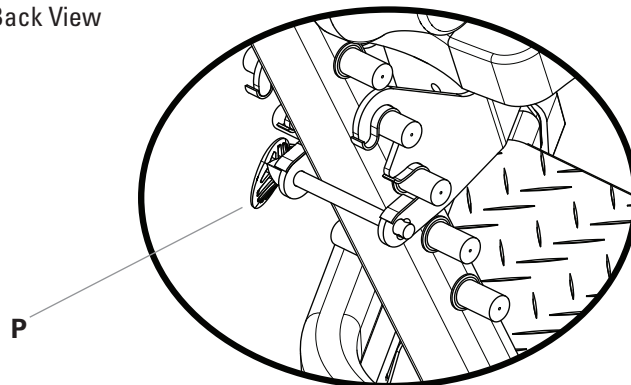

## 12. Upper Lat Tower Assembly

### Parts:

- Upper Lat Tower (11)
- Lat Cross Bar (10)
- Rear Lat Crossmember (9)

### Hardware:

- 2 Button Head Screws 3/8" X 3" (G)
- 4 Washers 3/8" (B)
- 2 Nylock Nuts 3/8" (O)
- 2 Button Head Screws 1/2" X 5 1/4" (J)
- 4 Wide Washers 1/2" (C)
- 2 Nylock Nuts 1/2" (N)

**Tool:** 7/32" Hex Wrench and Adjustable Wrench

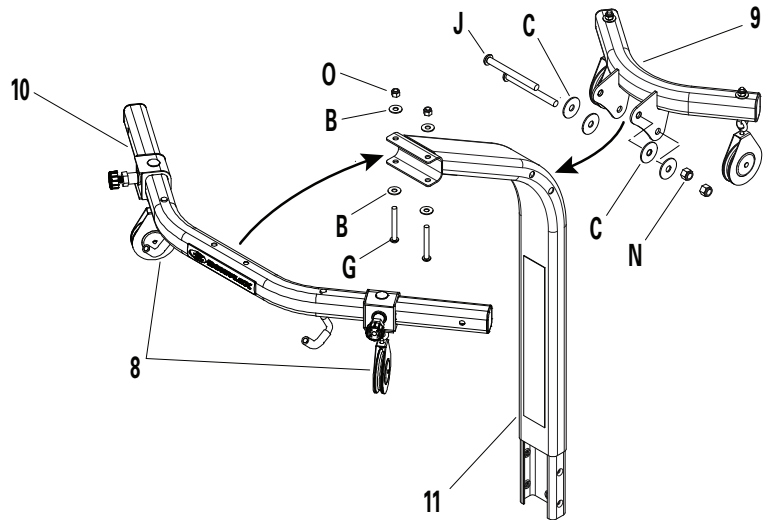

**12-1** Align the two holes on the Lat Cross Bar with those on the Upper Lat Tower as shown.

**12-2** Attach using 3/8" screws, washers and nuts as shown.

**Note:** Do not tighten hardware at this time.

**12-3** Align the bracket on the Rear Lat Crossmember with the bolt on the Upper Lat Tower as shown.

**12-4** Attach using 1/2" screws, washers and nuts as shown.

**12-5** Tighten all hardware from this step.

## 13. Ab Crunch Station Assembly

### Parts:

- Ab Crunch Bracket (20)
- Ab Crunch Crossbar (19)

### Hardware:

- 2 Button Head Screws 3/8" X 2 3/4" (Q)
- 4 Washers 3/8" (B)
- 2 Nylock Nuts 3/8" (O)

**Tool:** 7/32" Hex Wrench

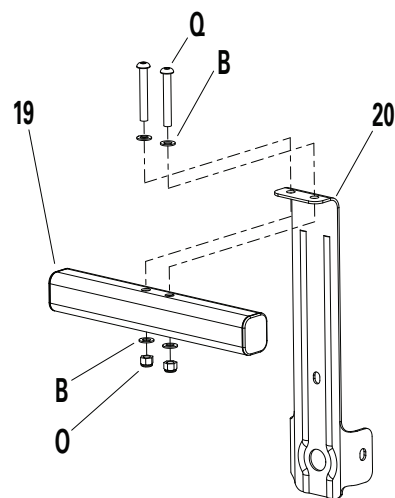

**13-1** Attach the Ab Crunch Crossbar to the Ab Crunch Bracket as shown. Tighten all hardware from this step.

## 14. Install Upper Lat Tower Assembly, Ab Crunch Station and Lat Pulley

### Parts:

- Upper Lat Tower Assembly
- Ab Crunch Station
- Lat Pulley Housing (22)
- Main Assembly

### Hardware:

- 5 Button Head Screws 3/8" X 3/4" (I)
- 5 Flat Washers 3/8" (B)

**Tool:** 7/32" Hex Wrench

- 14-1** Slide the Upper Lat Tower Assembly onto the Lower Lat Tower as shown.
- 14-2** Place the Ab Crunch Bracket against back of the Lat Tower Assembly. Align the bolt holes on the Ab Crunch Bracket's side flaps with the lower bolt holes on the sides of the Lat Tower.
- 14-3** To attach the Ab Crunch Station to the Lat Tower, install a 3/4" screw and washer through the upper bolt hole on the Ab Crunch Station into the back of the Lat Tower as shown in **Detail 14a**. Secure the Ab Crunch Station to the sides of the Lat Tower with 2 screws and washers as shown in **Detail 14a**.
- 14-4** Remove the plastic cap from the end of the the long bolt (\*) already installed in the back of the Lat Pulley/Housing. Finger tighten the bolt—it will be removed and reinstalled during Step 16 and 17.
- 14-5** Position the Lat Pulley Housing bracket against the Lat Tower, over the Ab Crunch Station. Align the bolt holes as shown in **Figure 14b**.
- 14-6** Place one washer over the end of each screw. Attach the Lat Pulley Housing to the Lat Tower by installing the screws loosely into the aligned holes as shown in **Figure 14b**.

**Do not tighten hardware at this time.**

**Figure 14a**

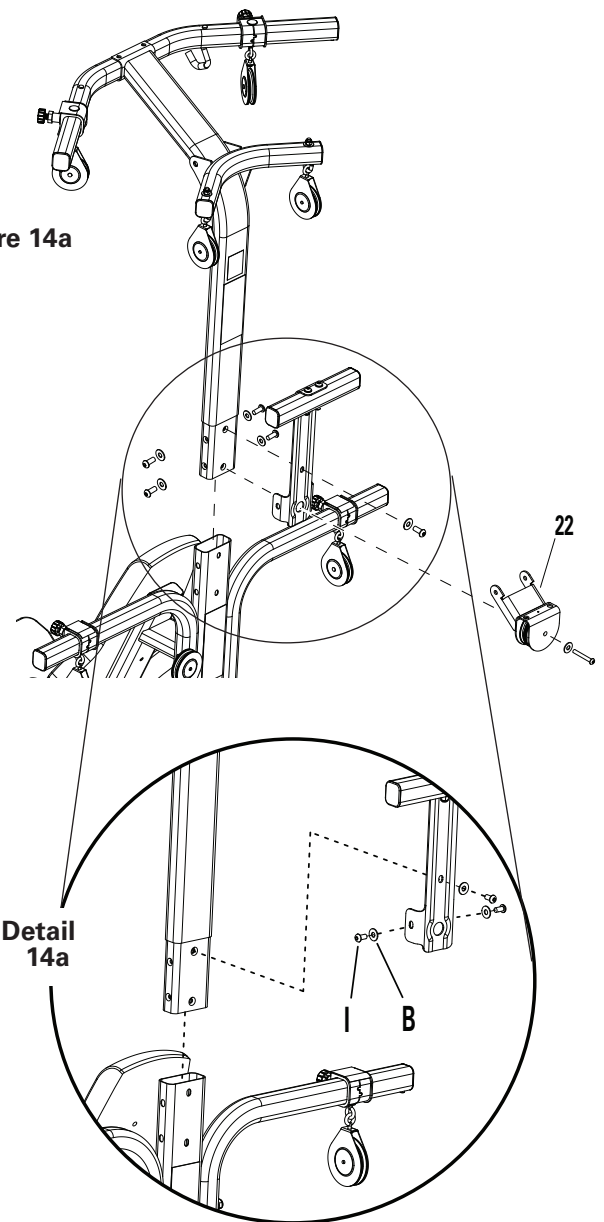

**Figure 14b**

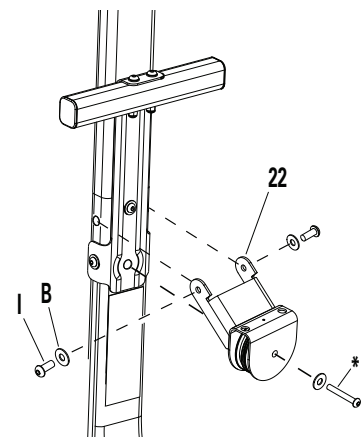

## 15. Cable and Pulley Routing - Overview

The figure below shows all Pulleys on the Bowflex Xtreme 2 SE home gym. Subsequent images show how to connect and route each of the Cables through the Pulleys. (The Ab Crunch Station is not shown for clarity.) Connecting the Cables is much easier with a second person assisting you.

**Note:** All references to the right or left of the machine are from the viewpoint of standing in front of the machine facing the seat. Your machine may not match the image. For reference only.

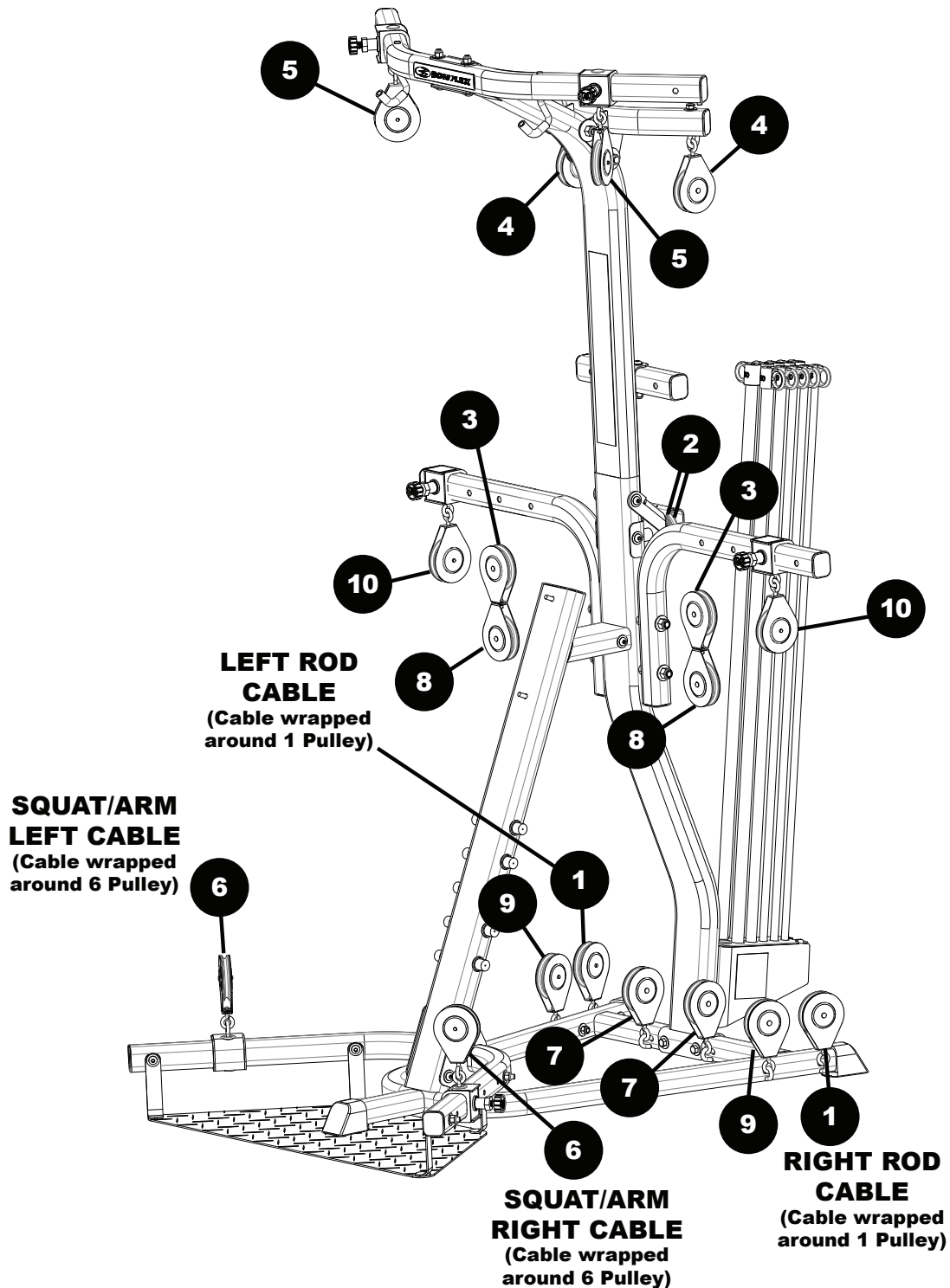



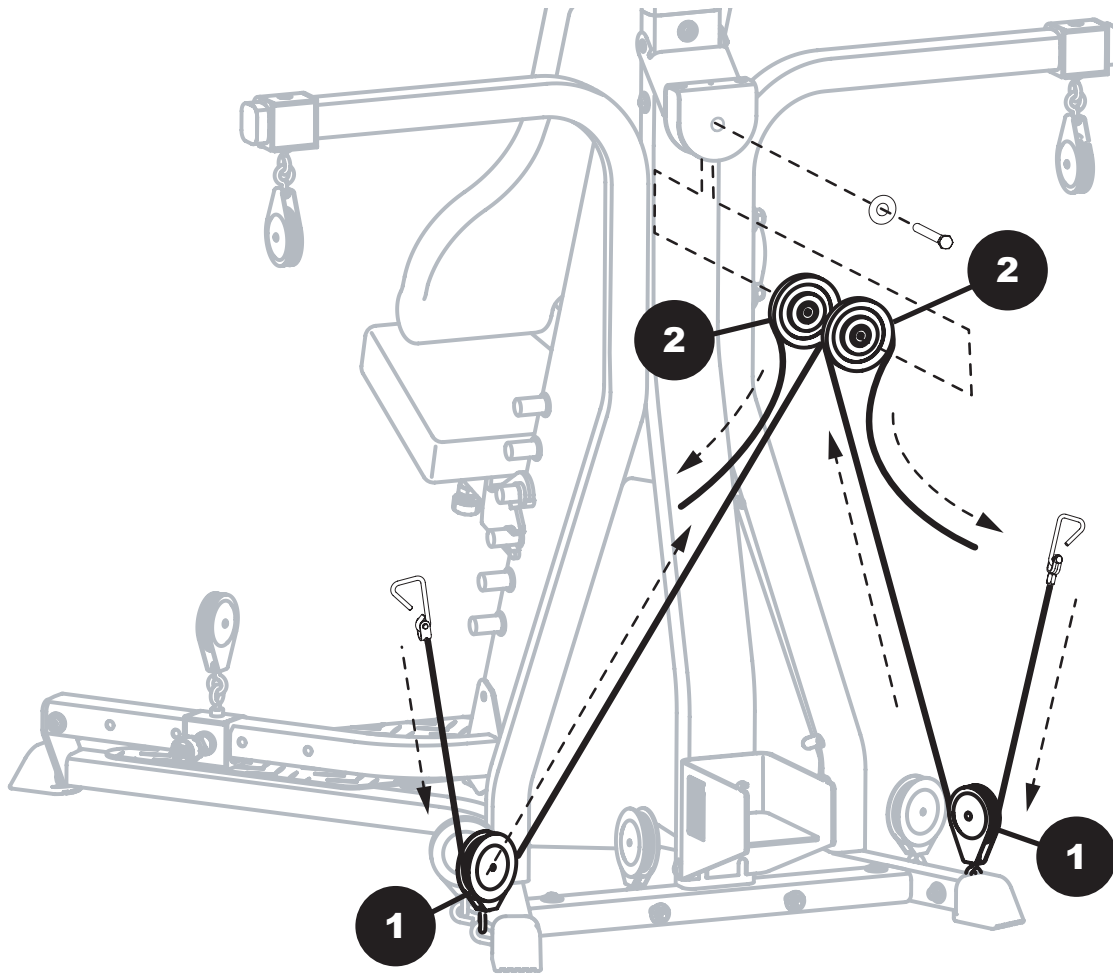

## 16. Cable and Pulley Routing – Prepare Cables to be installed to the Lat Pulley Housing

Locate the following items on the Lat Pulley Housing assembly:

- (2) Pulleys – already installed, labeled as item 2 in figure
- 3/8" X 4 1/2" Hex Head Bolt – installed
- 3/8" Washer – already installed

**Note:** Connecting the Cables is much easier with a second person assisting you.

**16-1** Remove the 4 1/2" Bolt and Washer from the back of the Lat Pulley Housing, and set safely aside for Step 18.

**16-2** The 2 Pulleys will slide down and out of the housing without the hex bolt holding them in place. Unwrap the Right Pulley Cable on the Right Frame Rail. Thread the cable beneath and then over one Lat Pulley (2), following the arrows shown in **Figure 16** and holding the cable tightly where indicated.

**16-3** Repeat for the Left Pulley Cable (on the Left Frame Rail), without loosening your grip on the Right Pulley Cable.

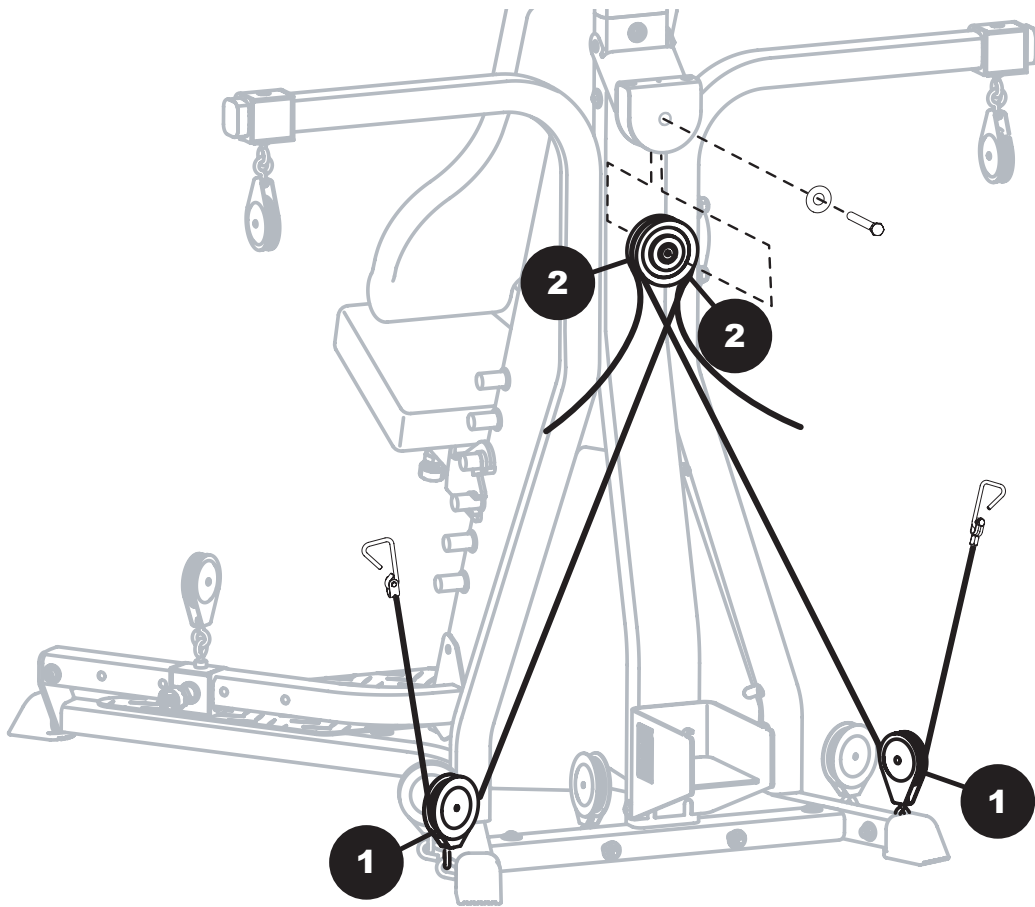

## 17. Cable and Pulley Routing – Connect Pulleys and Cables to the Lat Pulley Housing

Locate the following items for the Lat Pulley Housing assembly:

- (2) Pulleys from step 16
- 3/8" X 4 1/2" Hex Head Bolt – uninstalled in Step 16
- 3/8" Washer – uninstalled in Step 16

**Note:** Connecting the Cables is much easier with a second person assisting you.

**17-1** Holding both Cables from Step 16 in place, align the 2 Lat Pulleys as shown in **Figure 17**. Slide the Pulleys back into the Lat Pulley Housing, lining up the bolt holes in the Pulleys and Lat Pulley Housing.

**17-2** Place the Washer over the 4 1/2" Bolt from Step 16. Slide the Bolt through the aligned holes in the Lat Pulley Housing and Lat Pulleys as shown in **Figure 17**.

**Tighten all hardware.**

**Note:** You will probably need to push the Power Rod™ unit out of the way for this step. The Power Rod™ unit is not pictured for the sake of clarity.

## 18. Cable and Pulley Routing – Connect Rod Cables through the Right Floating and Lat Tower Pulleys

Locate the following items for the Lat Pulley Housing assembly:

- 3 & 8 Floating Pulleys (connected unit)
- (2) Cable End Stop Balls with Core (see Detail)

**18-1** Locate the Right Rod Cable that you ran through the Lat Pulley Housing. Thread the Cable through the (3) Floating Pulley, as shown.

**18-2** Continue to guide the Cable through the (4) Pulley on the Rear Lat Cross Bar, and then through the (5) Pulley on the Front Lat Cross Bar as shown.

**18-3** Insert the Cable End through the Cable End Stop Ball, and attach the Cable Core to keep the Cable from slipping back through the Pulleys. See **Figure 18b**.

**Note:** The Cable End Stop Ball Core should fit over the Ferrule when installed correctly. Rotate the Core to align it with the groove in the Ball.

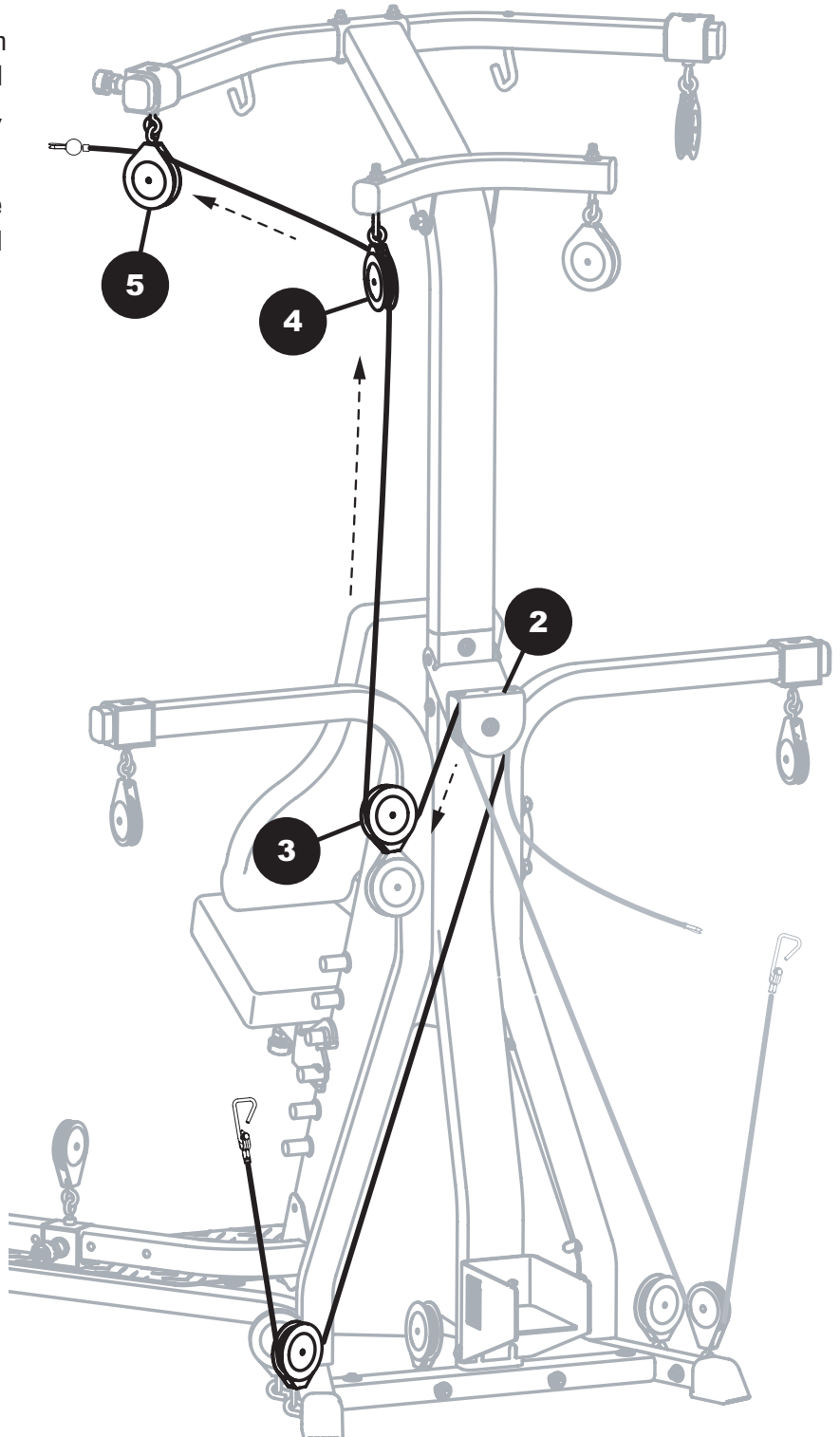

## 18b. Cable and Pulley Routing – Connect Cable End Stop Ball with Core

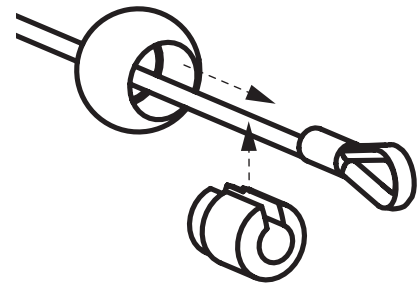

Figure 18b - Detail

## 18c. Cable and Pulley Routing – Connect Rod Cables through Left (3) Floating and Lat Tower Pulleys

18-4 Repeat with Left Rod Cable and (3) and (8) Floating Pulleys, as shown in **Figure 18c**.

**Note:** Once the Cable End Stop Balls are attached, hook each Rod Hook onto the Lat Pulley Housing as shown in **Figure 18d**.

Figure 18c

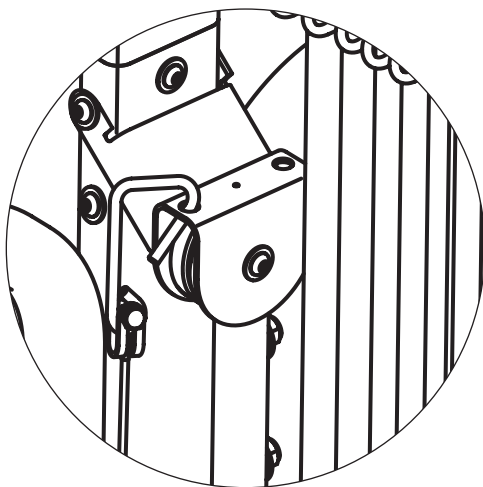
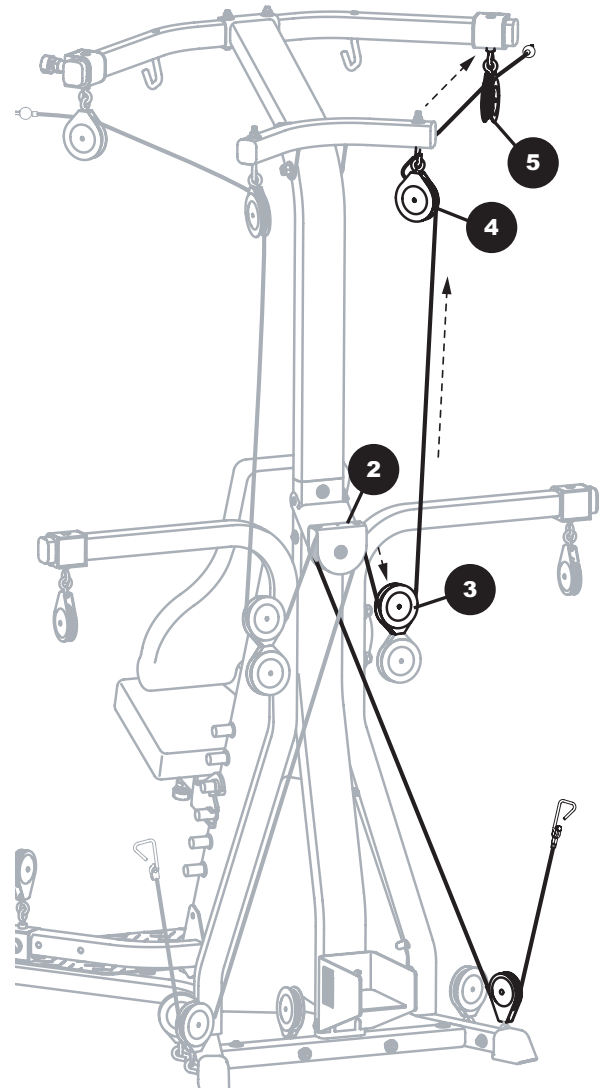
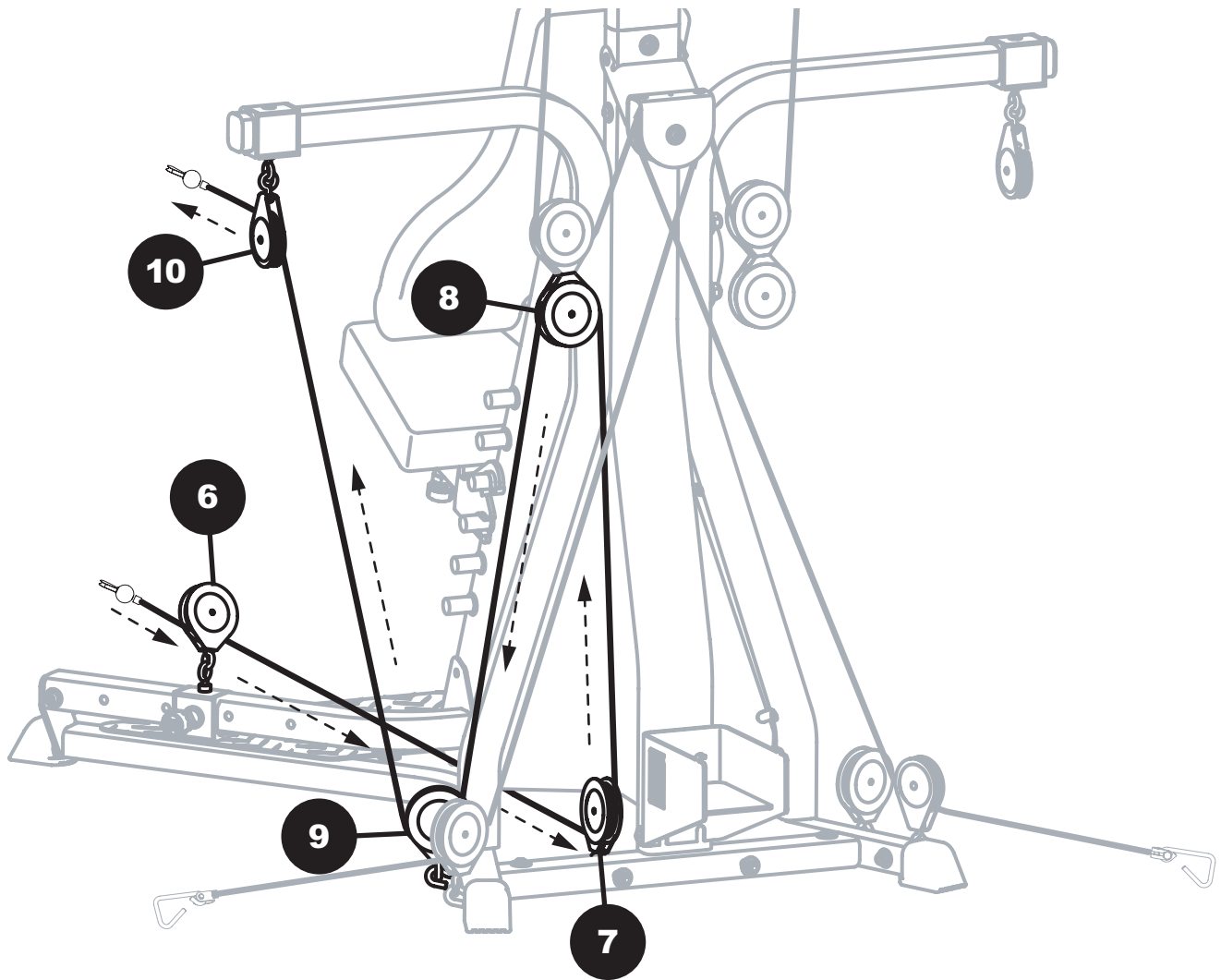

Figure 18d - Rod Hooks Storage on Lat Pulley Housing



## 19. Cable and Pulley Routing – Connect Right Squat Cable through the Floating and Main Assembly Pulleys

Slide the Right Squat Frame Pulley (6) to the furthest back hole, as indicated in **Figure 19**.

Unwrap the Right Squat Cable from the (6) Pulley and guide the Cable, threading under and through the Rear Cross Bar Pulley (7), and up through the Floating (8) Pulley. Follow the arrows as indicated in **Figure 19**.

Continue to guide the Cable down through the Inner Right Frame Rail Pulley (9), up through the Right Pulley Arm Pulley (10), as shown in **Figure 19**.

Finally, insert the Cable End through the Cable End Stop Ball and attach the Cable Core, as completed during Step 18.

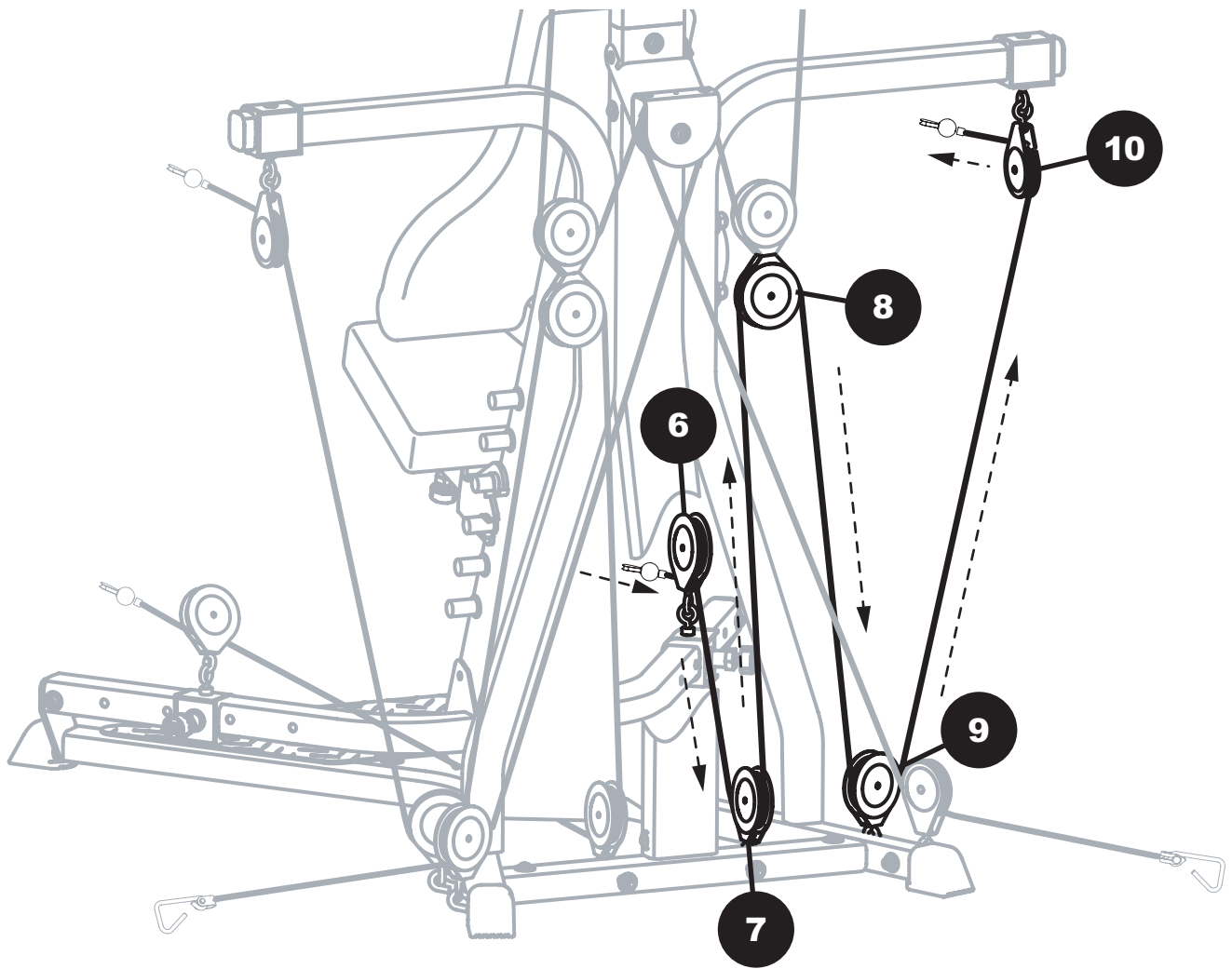

**19b. Cable and Pulley Routing -  
Connect Left Squat Cable through the Floating and Main Assembly Pulleys**

Repeat the same procedure completed during Step 19 for the Left Squat Cable.

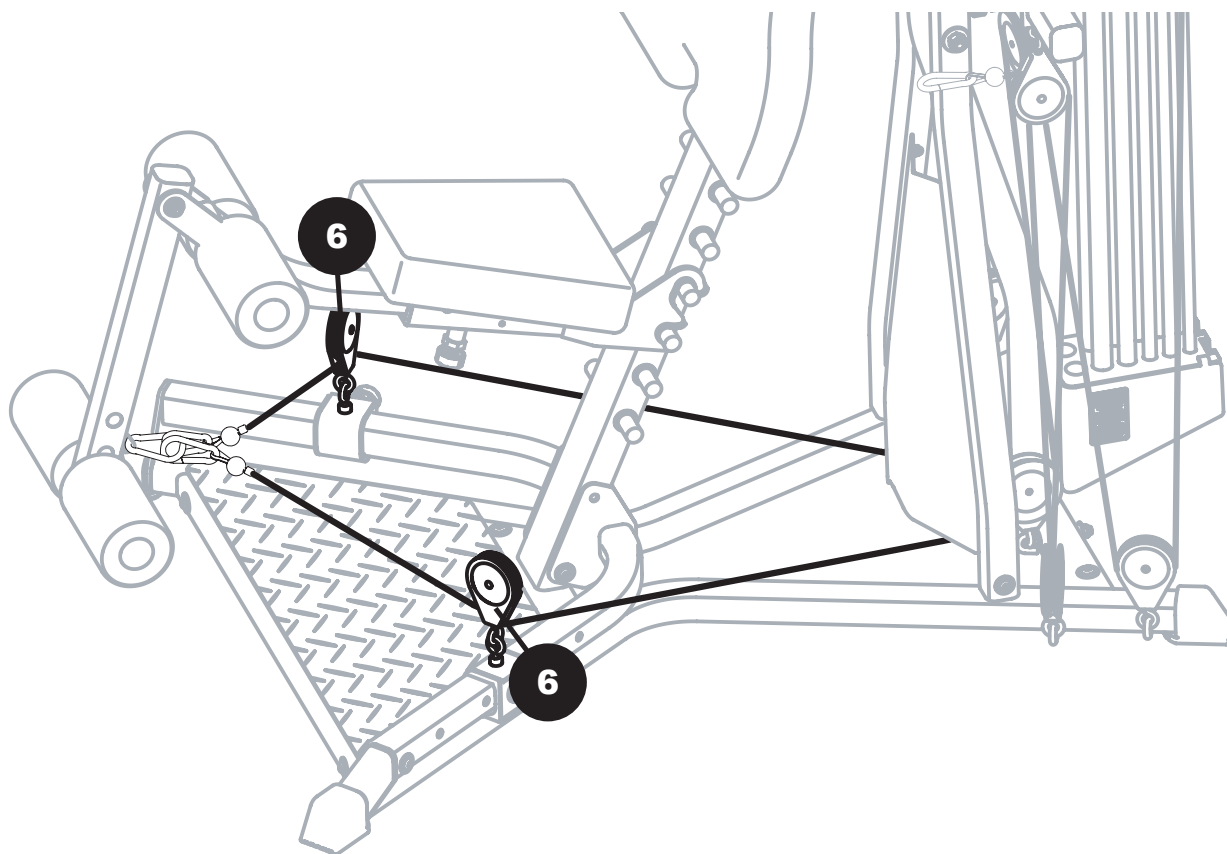

## 20. Cable & Pulley Routing

Unhook the Rod Hooks that were hooked to the Lat Pulley Housing in Step 18c (see **Figure 18d**).

Attach the hooks on the ends of the Left and Right Squat Cables to the Hook installed onto the Leg Extension, as shown in **Figure 20**.

## 21. Final Inspection

Inspect your machine to ensure that all fasteners are tight and components are properly assembled. Review all warnings affixed to machine.

Be sure to record the serial number in the field provided at the front of the Owner's Manual. Refer to the Safety Warning Labels and Serial Number section of the Owner's Manual.

**⚠ Failure to visually check and test assembly before use can cause damage to the equipment. It can also cause serious injury to users and bystanders.**

